

Job Name: _____

Location: _____

Engineer: _____

Submitted to: _____

Submitted by: _____

Reference: _____

Date: _____

Approval: _____

Construction: _____

Unit #: _____

Drawing #: _____

KEY FEATURES:

- Wide range for flexible installation (18K - 60K)
- Compatible with existing furnaces
- Multi-position Installation: Horizontal (left/right), Vertical (up/down)
- Full compatibility with universal third party outdoor condensing units utilizing R454B
- TXV Valve, Flared connection type, Aluminum coil with anti-corrosive GoldFin coating
- R454B refrigerant sensor

NOTES:



Indoor Model			CH-ACL48-60D
Power supply		V, Ph, Hz	208-230V, 1Ph, 60Hz
Communication wiring			AWG 20-2
Cooling	Capacity	Btu/h	45,000 (15,500~47,000)
	Input	w	4,500 (1,400~5,030)
	Rated current	A	18.3 (6.2~19)
	EER/EER2	Btu/w	
	SEER/SEER2	Btu/w	
Heating at 47 °F	Capacity	Btu/h	50,000 (16,000~52,000)
	Input	W	4,650 (1,200~5,300)
	Rated current	A	19 (5.2~23)
	COP	W/W	3.15
	HSPF4/HSPF2-4		8.4
	HSPF5/HSPF2-5		7.3
Indoor fan motor	Qty		/
	Input		/
	RLA		/
Indoor air flow (Turbo/Hi/Med/Lo) (No duct)		CFM	/
ESP (range)		ln.wg.	/
Indoor noise level (Hi/Med/Lo)		dB(A)	/
Dehumidification		L/H	14.2
Indoor unit	Dimensions (WxDxH)	inch	24-1/2 x 21 x 28
	Packing (WxDxH)	inch	27-3/4 x 26-1/8 x 30-3/8
	Net/Gross weight	lbs	81 / 92
Drainage water pipe diameter		inch	1"
Refrigerant piping (Liquid side/Gas side)		inch	3/8"/3/4"
Design pressure		PSIG	550/340
Controller			120N wire controller
Room temperature	Cooling	F	60~90
	Heating	F	32~86

Outdoor Model		CH-PQ48-230VO		
Power supply	V, Ph, Hz	208-230V, 1Ph, 60Hz		
Min. circuit ampacity	A	38		
Max. fuse	A	40		
Compressor	Model	MTH550UKPC8FU		
	Type	ROTARY		
	Brand	HIGHLY		
	Capacity	Btu/h	55,445	
	Input	w	4,900	
	Rated current (RLA)	A	28.0	
	Refrigerant oil	oz	HAF68D1C 60.9	
Outdoor fan motor	Qty	1		
	Input	w	250	
	RLA	A	2	
	Speed	r/min	850/800/750/650	
Outdoor air flow (Max)	CFM	3,037.1		
Outdoor noise level (Max)	dB(A)	65		
Throttle type		EXV		
Outdoor unit	Dimensions (WxDxH)	inch	38-9/16 x 16-3/8 x 38-3/8	
	Packing (WxDxH)	inch	45-1/16 x 19-11/16 x 42-1/2	
	Net/Gross weight	inch	201 / 232	
Refrigerant	Type	R454B		
	Precharge	ft	25	
Additional charge for 1/4 inch liquid pipe		oz	/	
Additional charge for 3/8 inch liquid pipe		oz	0.7	
Refrigerant piping	Liquid side/Gas side	inch	3/8"/3/4"	
	Max. pipe length	ft	246	
	Max. difference in level	ft	98.4	
Ambient temperature	Cooling	F	-22 ~ 122	
	Heating	F	-22~75	

Unit: in(mm)

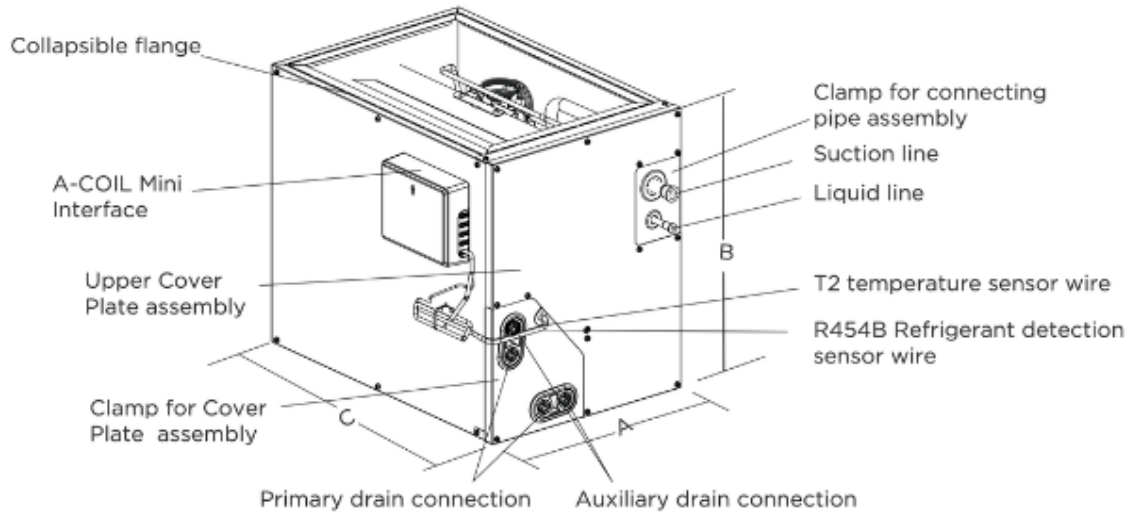

Model	CH-ACL18-24A		CH-ACL18-24B		CH-ACL30-36B	
Dimensions	inch	mm	inch	mm	inch	mm
A	14.5	368	17.5	445	17.5	445
B	18	457	18	457	23.5	599
C	21	533	21	533	21	533
Model	CH-ACL30-36C		CH-MCL48-60C		CH-ACL48-60D	
Dimensions	inch	mm	inch	mm	inch	mm
A	21	534	21.6	549	24.5	622
B	24	611	27.75	706	28	711
C	21	533	21.5	546	21	533

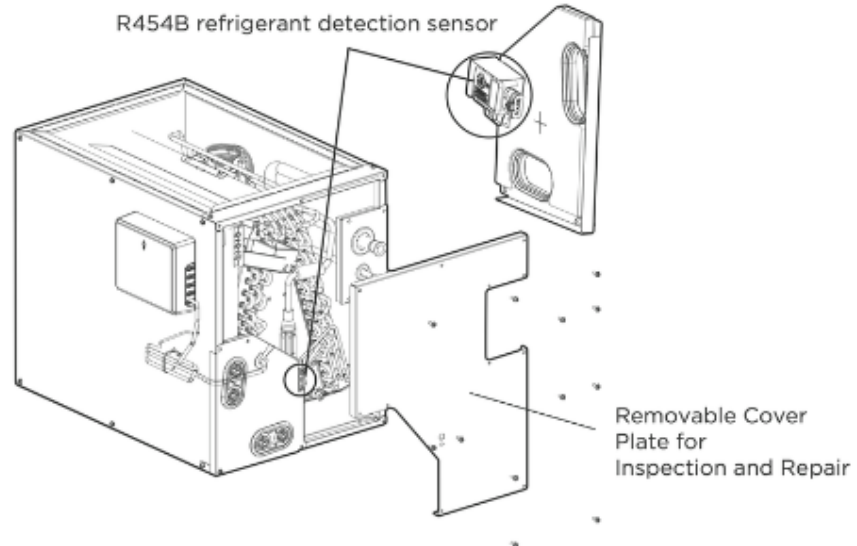

CASED DIMENSIONS AND COMPONENT LOCATION

PEAQ

