



**Split System
Cooling Only
Top Discharge**

SPLIT SYSTEM

OUTDOOR UNIT

Installation Manual

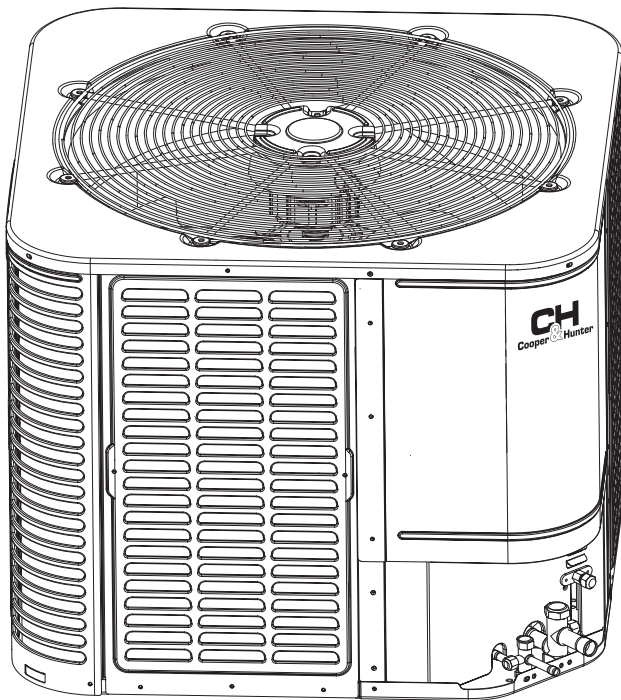

Models:

CH-UC18-230VO

CH-UC24-230VO

CH-UC30-230VO

CH-UC36-230VO

IMPORTANT NOTE:



Read this manual carefully before installing or operating your new air conditioning unit. Make sure to save this manual for future reference.





About the Company

With more than 25 years of experience in air conditioning and ventilation, **Cooper&Hunter** is considered one of the HVAC leaders in the US market. Distributed in more than 55 countries worldwide, the brand is dedicated to technological innovation and consumer-driven product development, while generating HVAC equipment that adheres to the highest quality standards in the US. Our focus is to provide reliable, energy-efficient, and cost-effective residential and commercial air conditioning solutions.

Learn more about your unit

Learn more technical information about your unit at www.cooperandhunter.us, where you can find submittals, leaflets, videos and all technical specifications of your unit.

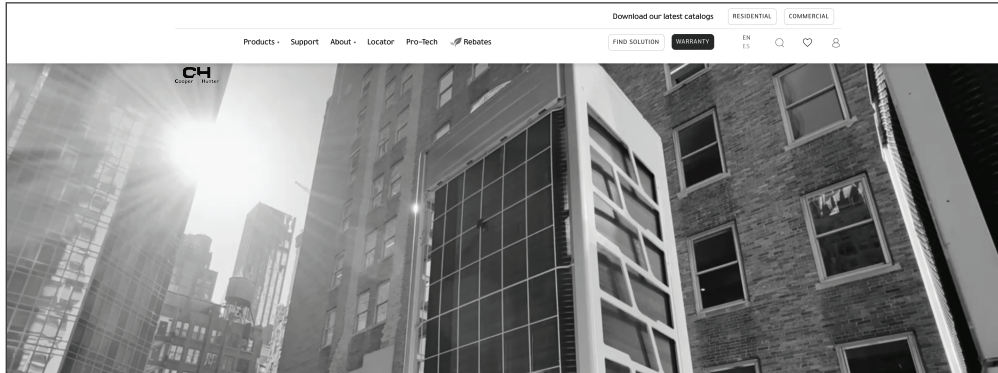

Step 1

On the website cooperandhunter.us, type in your unit model number into the search field and click enter.

Step 2

Make sure the unit that appears in your search results matches your unit and click on it for more details.

Step 3

On the detail page of your unit you will be able to view the technical specifications, description and additional documents, such as Submittals, Leaflets and Videos about your unit.

Warranty registration

It is important to register your unit's warranty. This will provide more security and agility whenever you need to request technical support from **Cooper&Hunter**.

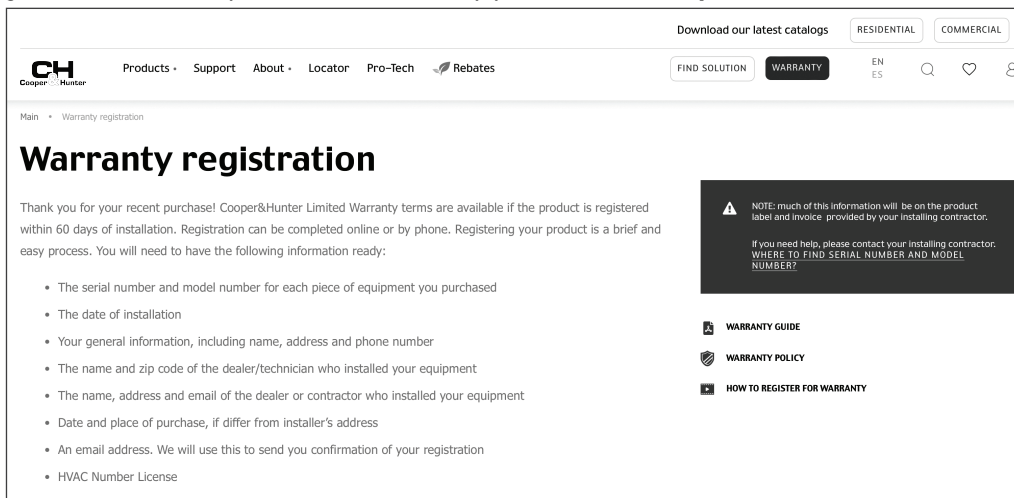

Step 1

Visit the warranty registration page at cooperandhunter.us/warranty and follow the steps to register a new unit. For more information on the warranty terms and policies, see pages at the end of your user manual.

Step 2

Complete the entire warranty registration form, including the information of the licensed technician who installed your equipment. Once complete, you will receive a confirmation email stating your application to register your unit has been submitted.

How to apply for the rebate program

Almost all **Cooper&Hunter** equipment is eligible for the rebate program. Visit **our website** to see if the rebates apply to your location.

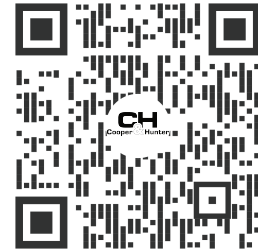
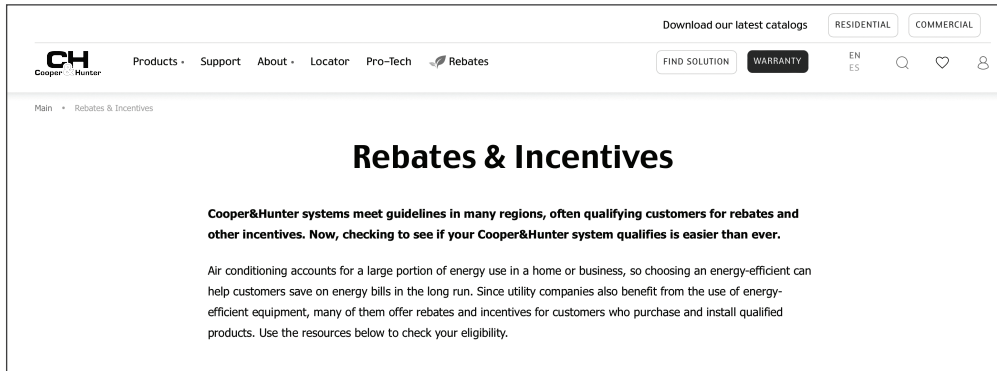

Step 1

Go to cooperandhunter.us/rebates to add your zip code and select your outdoor unit to see if your unit qualifies for the rebate.

Step 2

See the list of available rebates and instructions on how to apply for each available rebate.

Our Commitment to Innovation and Efficiency

At **Cooper&Hunter**, innovation is at the heart of everything we do. We continuously invest in research and development to bring you the most advanced, reliable, and energy-efficient HVAC solutions. Our goal is to lead the industry in environmental and energy efficiency, and we will spare no effort to achieve this.

We are proud to offer products that, not only meet, but exceed the highest quality standards. Our dedication to technological innovation ensures that you receive the best possible performance and value from your HVAC systems.

Explore more

For more information, including tutorials and updates, visit our official YouTube channel, Instagram and Facebook page. Simply search our social media to access a variety of helpful videos and guides.



 YouTube

@CooperandHunterusa



 Instagram

@cooperandhunterusa

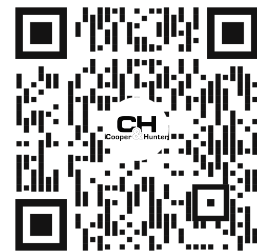

 Facebook

Cooper&Hunter USA

Remember to **subscribe** to stay up-to-date with the latest content!

CONTENTS

1. Symbol and Key to Safety Instructions.....	01
2. Considerations of Unit Location	09
3. Unit Installation Preparation	14
4. Unit Settings	15
5. Precautions for Refrigerant Pipeline.....	16
6. Refrigerant Pipeline Routing	18
7. Refrigerant Line Brazing.....	20
8. Refrigerant Line Leakage Inspection.....	22
9. Vacuuming.....	23
10. Service Valve.....	24
11. Electrical-Low Voltage	25
12. Electrical-High Voltage	28
13. Start.....	29
14. System Refrigerant Charging Method	30
15. System Operation and Troubleshooting	33
16. Wiring Diagram.....	40
17. Cleaning and Maintenance.....	41

1. Symbol and Key to Safety Instructions

1.1 Symbol Keywords

	WARNING	The warnings in this document are identified by warning triangles printed on a black background. The key words at the beginning of the warning indicate the type and severity of the next risk if no measures are taken to prevent it.
---	----------------	--

The following keywords are defined and used in this document:

<input type="checkbox"/>	Danger	Indicates a hazardous situation, which, if not avoided, will lead to death or serious injury.
<input type="checkbox"/>	Warning	Indicates a hazardous situation, which, if not avoided, may lead to death or serious injury.
<input type="checkbox"/>	Caution	Indicates a hazardous situation, which, if not avoided, may cause mild to moderate injury.
<input type="checkbox"/>	Note	Used to deal with behaviors unrelated to personal injury.

Important information

	This symbol represents important information that is not dangerous to people or property.
---	---

1.2 Safety

Please Read Before Continuing.

	WARNING	<input type="checkbox"/> Failure to observe this warning may result in property damage, serious personal injury or death.
		<input type="checkbox"/> Before touching the electrical components, wait for 3 minutes after disconnecting the power supply.

	NOTICE	<input type="checkbox"/> This document is the property of the customer and is kept by this unit. When you are finished, please return to the service information package.
		<input type="checkbox"/> These instructions do not cover all changes in the system, nor do they provide all unexpected situations that may be encountered during installation.
		<input type="checkbox"/> If you need more information, or there are special problems that are not sufficient for the buyer, you should consult your installation dealer or local dealer.



Some benefits of installing an approved indoor and outdoor split system are maximum efficiency, best performance and best overall system reliability.



This document contains wiring diagram and maintenance information. This is the customer's property and belongs to this unit. When you are finished, please return to the service information package.

Warning:

- The unit must be installed by qualified personnel with a capability certificated for handling refrigerant fluids. Refer to regulation and laws in use on installation location.
- Installation, service, maintenance and repair of this unit must be performed by a certified technician.
- Servicing shall be performed only as recommended by the manufacturer.
- Product uninstallation and recycling must be performed by a certified technician.
- The appliances is designed to be operated in outdoor area. If have to be installed indoor, the appliance shall be stored in a room without continuously operating open flames (for example an operating gas appliance) and ignition sources (for example an operating electric heater).
- This appliance is not intended for use by persons (including children) with reduced physical, sensory or mental capabilities, or lack of experience and knowledge, unless they have been given supervision or instruction concerning use of the appliance by a person responsible for their safety.
- The appliance shall be installed in accordance with national wiring regulations.
- Children should be supervised to ensure that they do not play with the appliance.
- Before accessing the connection terminals, all power circuits must be disconnected.
- This information is intended for use by individuals with sufficient electrical and mechanical experience background. Attempting to repair central air conditioning products may result in personal injury and/or property damage.



Warning: Dangerous voltage

- Failure to observe this warning may result in property damage, serious personal injury or death.
- Can cause injury or death. Disconnect all remote electric power supplies before servicing. Follow proper locking/tagging procedures to ensure that the power supply will not be energized accidentally.



Warning: Refrigerant oil

- Attempting to repair central air-conditioning products may result in property damage, serious personal injury or death. These units use R32 refrigerant, and its working pressure is 50-70% higher than R22. Use only the service equipment approved by R32. The refrigerant cylinder is painted "rose" to indicate the type of refrigerant, and may contain a "dip" tube to allow liquid refrigerant to be filled into the system. This systems use POE oil, which can easily absorb moisture from the atmosphere. In order to limit this "moisture absorption" effect, the system should be sealed as much as possible. If the system is exposed to the atmosphere for more than 4 hours, the compressor oil must be changed. Do not destroy the vacuum with air, and always replace the filter dryer when you open the system for component replacement.





Warning: Hot surface

- May cause mild to severe burns. Failure to observe this caution may result in property damage or personal injury. Do not touch the top of the compressor.



Caution: Contains refrigerant

- Failure to follow the correct procedures will lead to personal illness or injury or serious equipment damage. The system contains high-pressure oil and refrigerant. Before opening the system, recover the refrigerant to release the pressure.



Note:

- The manufacturer recommends installing only approved matched indoor and outdoor systems. Some of the benefits of installing approved matched indoor and outdoor split systems are maximum efficiency, optimum performance and the best overall system reliability.



Note: Grounding required

- Failure to check or use the correct maintenance tools may result in equipment damage or personal injury. Reconnect all grounding devices. All parts of this product that can conduct current are grounded. If the grounding wire, screw, strap, clip, nut or washer used to complete the grounding path is removed during maintenance, it must be put back in place and properly fixed.



Warning: service valve

- Failure to observe this warning will result in release of system pressure, which may result in personal injury and/or property damage. When opening the liquid pipeline service valve, be extra careful. Turn the valve stem counterclockwise until the valve stem touches the bead.



Warning: Brazing required

- Failure to check the wiring or use the correct maintenance tools may result in equipment damage or personal injury. If using existing refrigerant lines, make sure that all joints are brazed, not soldered.



Warning: High current leakage

- Failure to observe this warning may result in property damage, serious personal injury or death. Before connecting the power supply, grounding is essential.







Warning:

- This product may expose you to chemicals including lead and lead components, which are known to cause cancer, birth defects or other reproductive harm in California. For more information, please visit www.P65Warnings.ca.gov.

Warning:



- Do not use means to accelerate the defrosting process or to clean, other than those recommended by the manufacturer.
- The appliances is designed to be operated in outdoor area. If have to be installed indoor, the appliance shall be stored in a room without continuously operating ignition sources (for example: open flames, an operating gas appliance or an operating electric heater.)
- Do not pierce or burn.
- Be aware that refrigerants may not contain an odour.

	WARNING	This symbol that this appliance used a flammable refrigerant. If the refrigerant is leaked and exposed to an external ignition source, there is a risk of fire.
	CAUTION	This symbol that the operation manual should be read carefully.
	CAUTION	This symbol that a service personnel should be handling this equipment with reference to the installation manual.
	CAUTION	This symbol that information is available such as the operating manual or installation manual.

1.3 Instructions for repairing appliances containing R32

Warning:



- Do not use means to accelerate the defrosting process or to clean, other than those recommended by the manufacturer.
- The appliance shall be stored in a room without continuously operating ignition sources (for example: open flames, an operating gas appliance or an operating electric heater.)
- Do not pierce or burn.
- Be aware that refrigerants may not contain an odour.

Qualification of workers

Every working procedure like maintenance, service and repair operations that affects safety means shall only be carried out by competent persons.

Examples for such working procedures are:

- breaking into the refrigerating circuit;
- opening of sealed components;
- opening of ventilated enclosures.

Checks to the area

Prior to beginning work on systems containing FLAMMABLE REFRIGERANTS, safety checks are necessary to ensure that the risk of ignition is minimised.

Work procedure

Work shall be undertaken under a controlled procedure so as to minimise the risk of a flammable gas or vapour being present while the work is being performed.

General work area

All maintenance staff and others working in the local area shall be instructed on the nature of work being carried out. Work in confined spaces shall be avoided.

Checking for presence of refrigerant

The area shall be checked with an appropriate refrigerant detector prior to and during work, to ensure the technician is aware of potentially toxic or flammable atmospheres. Ensure that the leak detection equipment being used is suitable for use with all applicable refrigerants, i.e. non-sparking, adequately sealed or intrinsically safe.

Presence of fire extinguisher

If any hot work is to be conducted on the refrigerating equipment or any associated parts, appropriate fire extinguishing equipment shall be available to hand. Have a dry powder or CO2 fire extinguisher adjacent to the charging area.

No ignition sources

No person carrying out work in relation to a REFRIGERATING SYSTEM which involves exposing any pipe work shall use any sources of ignition in such a manner that it may lead to the risk of fire or explosion. All possible ignition sources, including cigarette smoking, should be kept sufficiently far away from the site of installation, repairing, removing and disposal, during which refrigerant can possibly be released to the surrounding space. Prior to work taking place, the area around the equipment is to be surveyed to make sure that there are no flammable hazards or ignition risks. "No Smoking" signs shall be displayed.

Ventilated area

Ensure that the area is in the open or that it is adequately ventilated before breaking into the system or conducting any hot work. A degree of ventilation shall continue during the period that the work is carried out. The ventilation should safely disperse any released refrigerant and preferably expel it externally into the atmosphere.

Checks to the refrigerating equipment

Where electrical components are being changed, they shall be fit for the purpose and to the correct specification. At all times the manufacturer's maintenance and service guidelines shall be followed. If in doubt, consult the manufacturer's technical department for assistance.

The following checks shall be applied to installations using FLAMMABLE REFRIGERANTS:

- the actual REFRIGERANT CHARGE is in accordance with the room size within which the refrigerant containing parts are installed;
- the ventilation machinery and outlets are operating adequately and are not obstructed;
- if an indirect refrigerating circuit is being used, the secondary circuit shall be checked for the presence of refrigerant
- marking to the equipment continues to be visible and legible. Markings and signs that are illegible shall be corrected;
- refrigerating pipe or components are installed in a position where they are unlikely to be exposed to any substance which may corrode refrigerant containing components, unless the components are constructed of materials which are inherently resistant to being corroded or are suitably protected against being so corroded.

Checks to electrical devices

Repair and maintenance to electrical components shall include initial safety checks and component inspection procedures. If a fault exists that could compromise safety, then no electrical supply shall be connected to the circuit until it is satisfactorily dealt with. If the fault cannot be corrected immediately but it is necessary to continue operation, an adequate temporary solution shall be used. This shall be report-

ed to the owner of the equipment so all parties are advised. Initial safety checks shall include:

- that capacitors are discharged: this shall be done in a safe manner to avoid possibility of sparking;
- that no live electrical components and wiring are exposed while charging, recovering or purging the system;
- that there is continuity of earth bonding.

Repairs to sealed components

Sealed electrical components shall be replaced.

Repair to intrinsically safe components

Intrinsically safe components must be replaced.

Cabling

Check that cabling will not be subject to wear, corrosion, excessive pressure, vibration, sharp edges or any other adverse environmental effects. The check shall also take into account the effects of aging or continual vibration from sources such as compressors or fans.

Detection of flammable refrigerants

Under no circumstances shall potential sources of ignition be used in the searching for or detection of refrigerant leaks. A halide torch (or any other detector using a naked flame) shall not be used.

The following leak detection methods are deemed acceptable for all refrigerant systems.

Electronic leak detectors may be used to detect refrigerant leaks but, in the case of FLAMMABLE REFRIGERANTS, the sensitivity may not be adequate, or may need re-calibration. (Detection equipment shall be calibrated in a refrigerant-free area.) Ensure that the detector is not a potential source of ignition and is suitable for the refrigerant used. Leak detection equipment shall be set at a percentage of the LFL of the refrigerant and shall be calibrated to the refrigerant employed, and the appropriate percentage of gas (25% maximum) is confirmed.

Leak detection fluids are also suitable for use with most refrigerants but the use of detergents containing chlorine shall be avoided as the chlorine may react with the refrigerant and corrode the copper pipe-work.

If a leak is suspected, all naked flames shall be removed/extinguished.

If a leakage of refrigerant is found which requires brazing, all of the refrigerant shall be recovered from the system, or isolated (by means of shut off valves) in a part of the system remote from the leak. Removal of refrigerant shall be according to Removal and evacuation.

Removal and evacuation

When breaking into the refrigerant circuit to make repairs – or for any other purpose –conventional procedures shall be used. However, for flammable refrigerants it is important that best practice be followed, since flammability is a consideration. The following procedure shall be adhered to:

- safely remove refrigerant following local and national regulations;
- evacuate;
- purge the circuit with inert gas (optional for A2L);
- evacuate (optional for A2L);
- continuously flush or purge with inert gas when using flame to open circuit; and
- open the circuit.

The refrigerant charge shall be recovered into the correct recovery cylinders if venting is not allowed by local and national codes. For appliances containing flammable refrigerants, the system shall be purged with oxygen-free nitrogen to render the appliance safe for flammable refrigerants. This process might need to be repeated several times. Compressed air or oxygen shall not be used for purging refrigerant systems.

For appliances containing flammable refrigerants, refrigerants purging shall be achieved by breaking the vacuum in the system with oxygen-free nitrogen and continuing to fill until the working pressure is achieved, then venting to atmosphere, and finally pulling down to a vacuum (optional for A2L). This pro-

cess shall be repeated until no refrigerant is within the system (optional for A2L). When the final oxygen-free nitrogen charge is used, the system shall be vented down to atmospheric pressure to enable work to take place.

The outlet for the vacuum pump shall not be close to any potential ignition sources, and ventilation shall be available.

Charging procedures

In addition to conventional charging procedures, the following requirements shall be followed.

- Ensure that contamination of different refrigerants does not occur when using charging equipment. Hoses or lines shall be as short as possible to minimise the amount of refrigerant contained in them.
- Cylinders shall be kept in an appropriate position according to the instructions.
- Ensure that the REFRIGERATING SYSTEM is earthed prior to charging the system with refrigerant
- Label the system when charging is complete (if not already).
- Extreme care shall be taken not to overfill the REFRIGERATING SYSTEM.
Prior to recharging the system, it shall be pressure-tested with the appropriate purging gas. The system shall be leak-tested on completion of charging but prior to commissioning. A follow up leak test shall be carried out prior to leaving the site.

Decommissioning

Before carrying out this procedure, it is essential that the technician is completely familiar with the equipment and all its detail. It is recommended good practice that all refrigerants are recovered safely. Prior to the task being carried out, an oil and refrigerant sample shall be taken in case analysis is required prior to re-use of recovered refrigerant. It is essential that electrical power is available before the task is commenced.

- a) Become familiar with the equipment and its operation.
- b) Isolate system electrically.
- c) Before attempting the procedure, ensure that:
 - mechanical handling equipment is available, if required, for handling refrigerant cylinders;
 - all personal protective equipment is available and being used correctly;
 - the recovery process is supervised at all times by a competent person;
 - recovery equipment and cylinders conform to the appropriate standards.
- d) Pump down refrigerant system, if possible.
- e) If a vacuum is not possible, make a manifold so that refrigerant can be removed from various parts of the system.
- f) Make sure that cylinder is situated on the scales before recovery takes place.
- g) Start the recovery machine and operate in accordance with instructions.
- h) Do not overfill cylinders (no more than 80% volume liquid charge).
- i) Do not exceed the maximum working pressure of the cylinder, even temporarily.
- j) When the cylinders have been filled correctly and the process completed, make sure that the cylinders and the equipment are removed from site promptly and all isolation valves on the equipment are closed off.
- k) Recovered refrigerant shall not be charged into another REFRIGERATING SYSTEM unless it has been cleaned and checked

Labelling

Equipment shall be labelled stating that it has been de-commissioned and emptied of refrigerant. The label shall be dated and signed. For appliances containing FLAMMABLE REFRIGERANTS, ensure that there are labels on the equipment stating the equipment contains FLAMMABLE REFRIGERANT.

Recovery

When removing refrigerant from a system, either for servicing or decommissioning, it is recommended good practice that all refrigerants are removed safely.

When transferring refrigerant into cylinders, ensure that only appropriate refrigerant recovery cylinders

are employed. Ensure that the correct number of cylinders for holding the total system charge is available. All cylinders to be used are designated for the recovered refrigerant and labelled for that refrigerant (i.e. special cylinders for the recovery of refrigerant). Cylinders shall be complete with pressure-relief valve and associated shut-off valves in good working order. Empty recovery cylinders are evacuated and, if possible, cooled before recovery occurs.

The recovery equipment shall be in good working order with a set of instructions concerning the equipment that is at hand and shall be suitable for the recovery of the flammable refrigerant. If in doubt, the manufacturer should be consulted. In addition, a set of calibrated weighing scales shall be available and in good working order. Hoses shall be complete with leak-free disconnect couplings and in good condition.

The recovered refrigerant shall be processed according to local legislation in the correct recovery cylinder, and the relevant waste transfer note arranged. Do not mix refrigerants in recovery units and especially not in cylinders.

If compressors or compressor oils are to be removed, ensure that they have been evacuated to an acceptable level to make certain that flammable refrigerant does not remain within the lubricant. The compressor body shall not be heated by an open flame or other ignition sources to accelerate this process. When oil is drained from a system, it shall be carried out safely.

2. Considerations of Unit Location

2.1 Unit Size

Table 2.1 Outdoor Operating Temperature

Model	Temperature
Cooling mode	57~118°F

Table 2.2

Model	Unit size(H × W × L (inches))
18K/24K	25 × 21-4/5 × 21-4/5
30K/36K	25 × 29-1/7 × 29-1/7

The weight of the unit is attached to the carton.

When installing the outdoor unit on the roof, make sure that the roof can support the weight of the outdoor unit. It is recommended to choose appropriate isolation to prevent sound or vibration from being transmitted to the building structure.

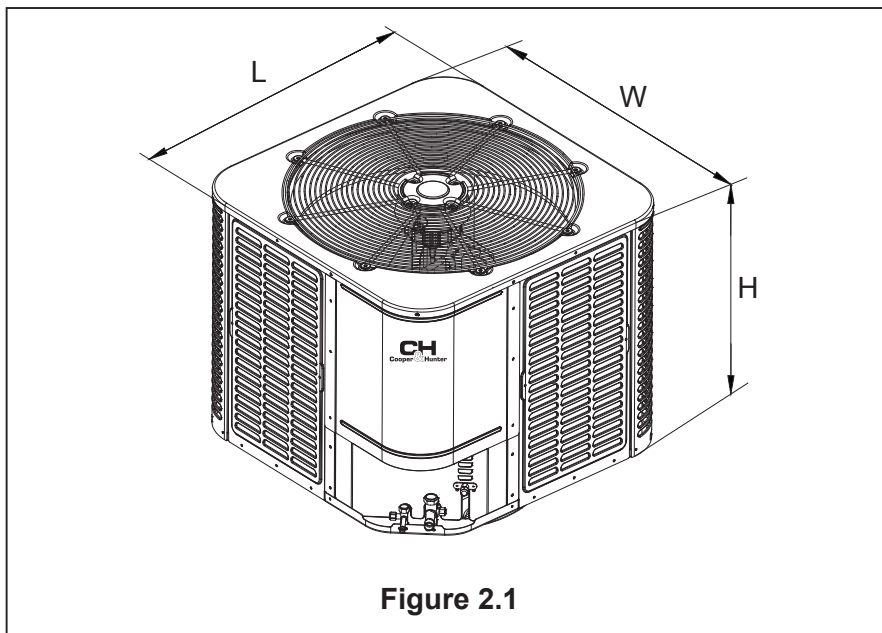

2.2 Refrigerant Pipeline Restriction

Table 2.3 Long line set application

Refrigerant Piping		Capacity (Btu/h)			
		18K	24K	30K	36K
Liquid-Vapor	In.	3/8-3/4	3/8-3/4	3/8-3/4	3/8-3/4
Max. Refrigerant Line Length*	Ft.	131			
Max. Vertical Lift	Ft.	66			

* It is recommended to adopt standard pipeline size; Refrigerant charge: see Section 14.

- ▶ Maximum equivalent length of pipeline = 131 feet.
- ▶ Maximum vertical equivalent length = 66 feet.
- ▶ Use only the pipe diameters shown in Table 2.3.

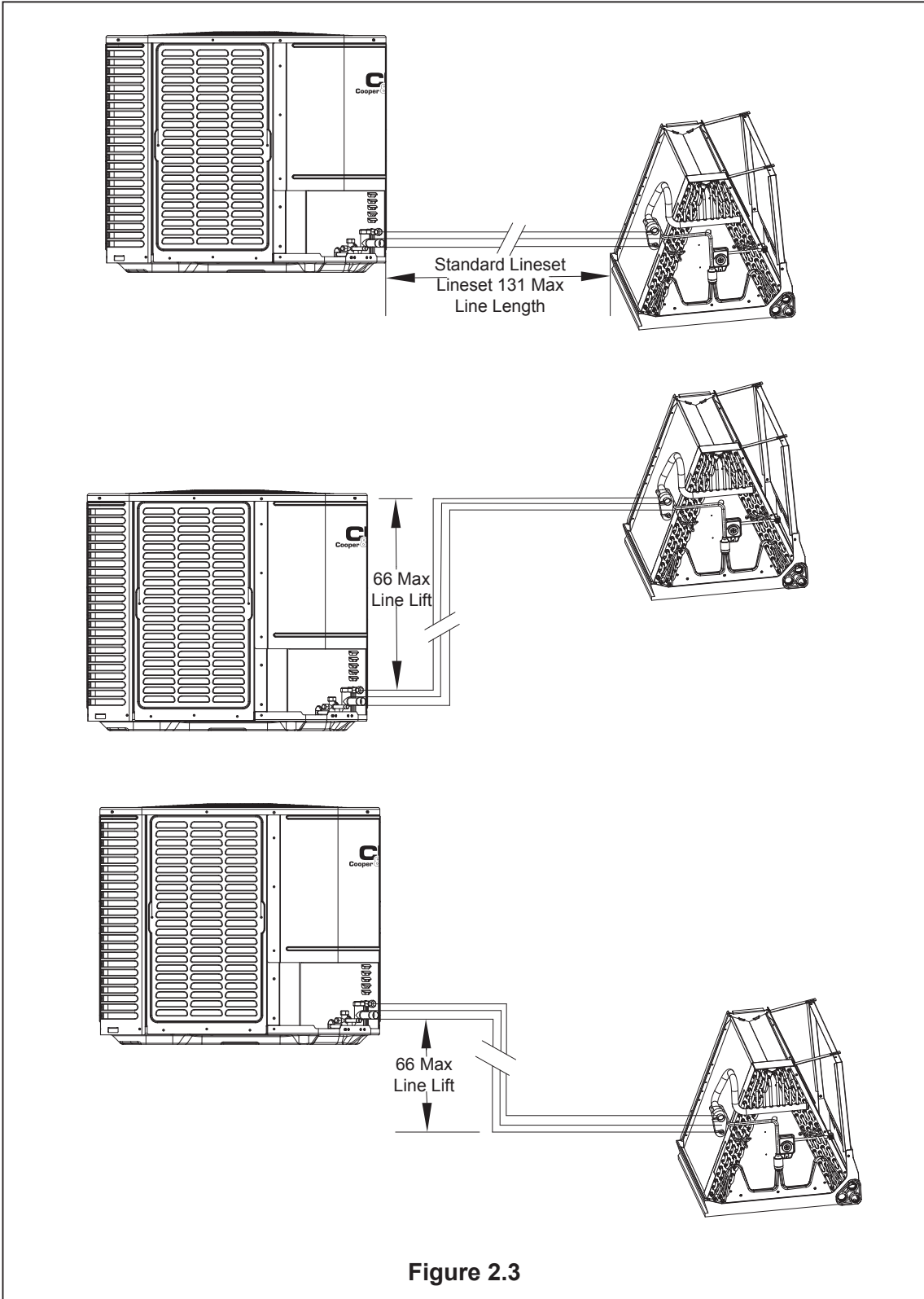

2.3 Long Line Installation Precautions

- If all long lines are in a horizontal state, no additional measures are required;
- If there is a vertical height difference in the long line, it needs to be installed according to the following requirements:
- An oil trap needs to be installed when outdoor unit is above indoor unit over 40 ft.

NOTE: Remember to add the equivalent length from oil traps to the equivalent length calculation of the suction line.

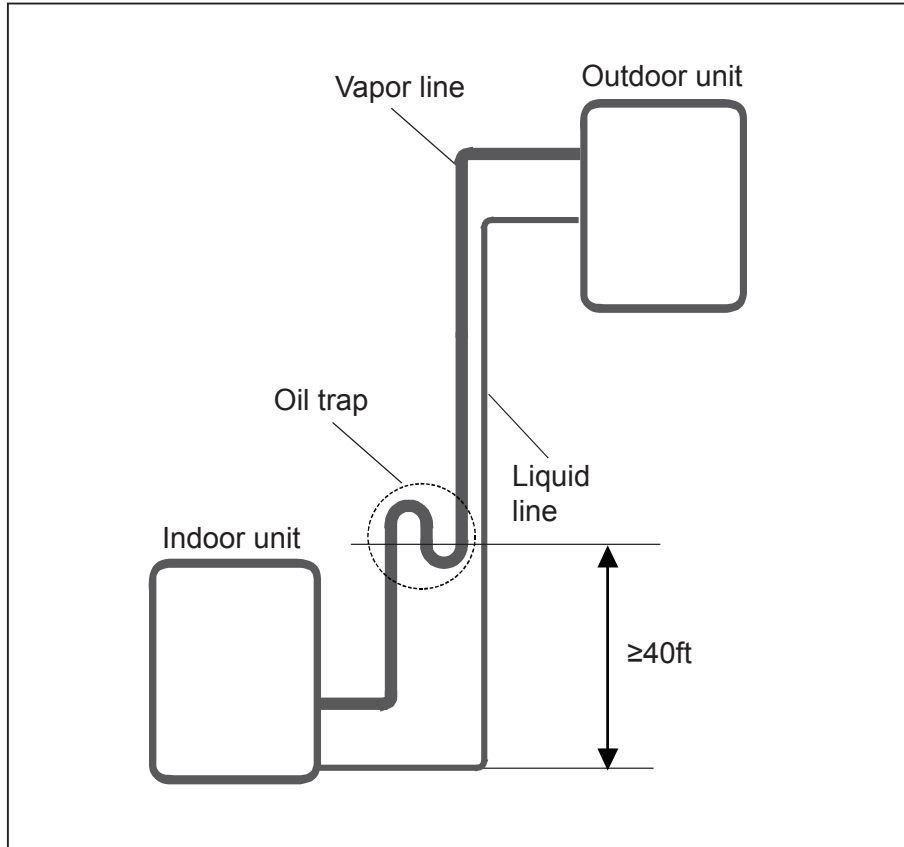
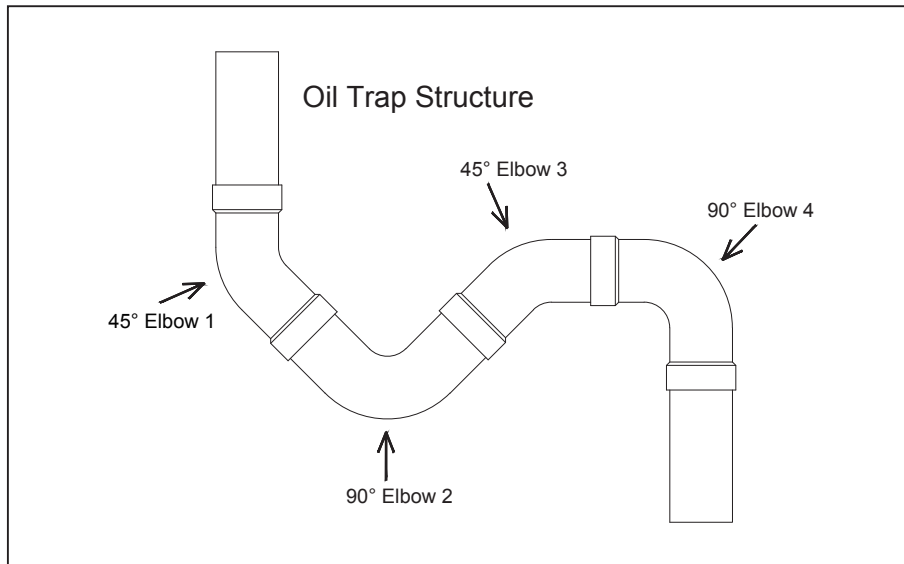

2.4 Position Restriction

- Make sure that the discharge area at least 60 inches above the top of the unit is unrestricted.
- Don't put the outdoor unit near the bedroom, because the normal operating sound may be offensive.
- Position the equipment, leaving enough space for smooth airflow, wiring, refrigerant lines and maintainability.
- Allow a minimum of 12 inches clearance on one side of control board access panel to a wall and a minimum of 24 inches on the adjacent side of control board access panel.
- Keep a distance of 24 inches between adjacent units.
- Place the unit in a place where water, snow or ice cannot fall directly on the device from the roof or overhangs.
- See figures 2.4 and 2.5.

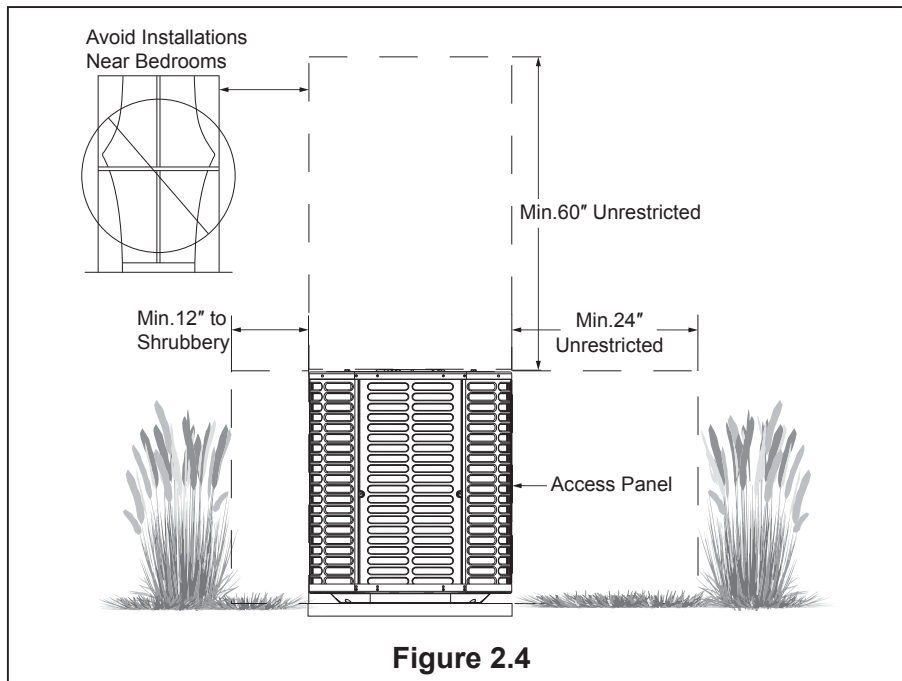

Figure 2.4

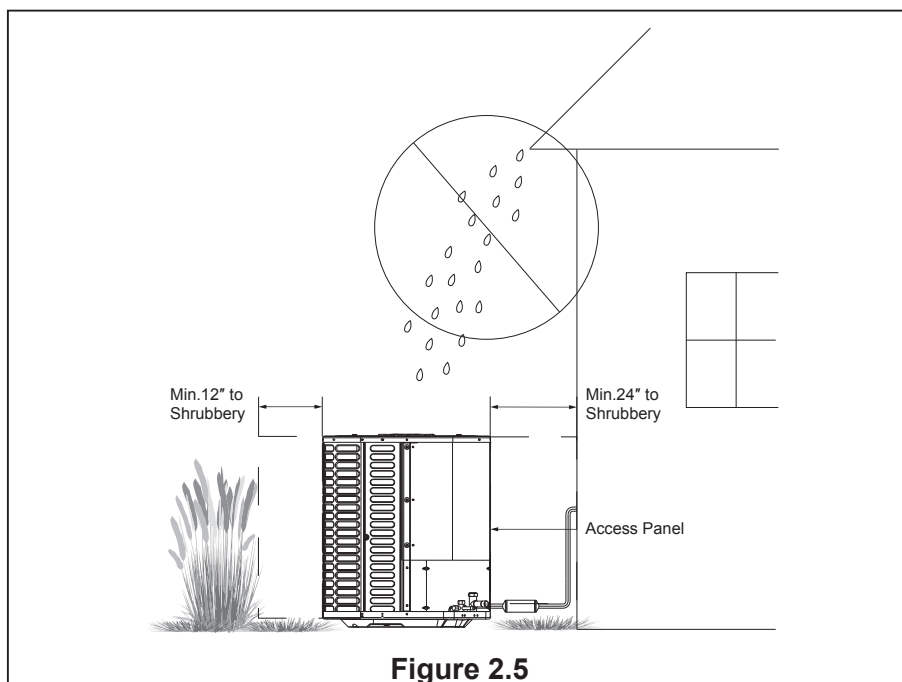

Figure 2.5

Precautions in cold climate



Precautions must be taken for units installed in areas with snow and long-term temperatures below freezing point.

- Depending on the local weather conditions, the unit should be raised by 3-12 inches. This extra height will allow the snow and ice melted during the defrosting cycle to be discharged before re-freezing. Make sure that the drain hole on the unit chassis is not blocked, otherwise it will hinder the defrosting water discharge (Figure 2.6).
- If possible, avoid places that are prone to snow. If this is not feasible, a snow barrier should be installed around the unit to prevent snow accumulation on the side of the unit.

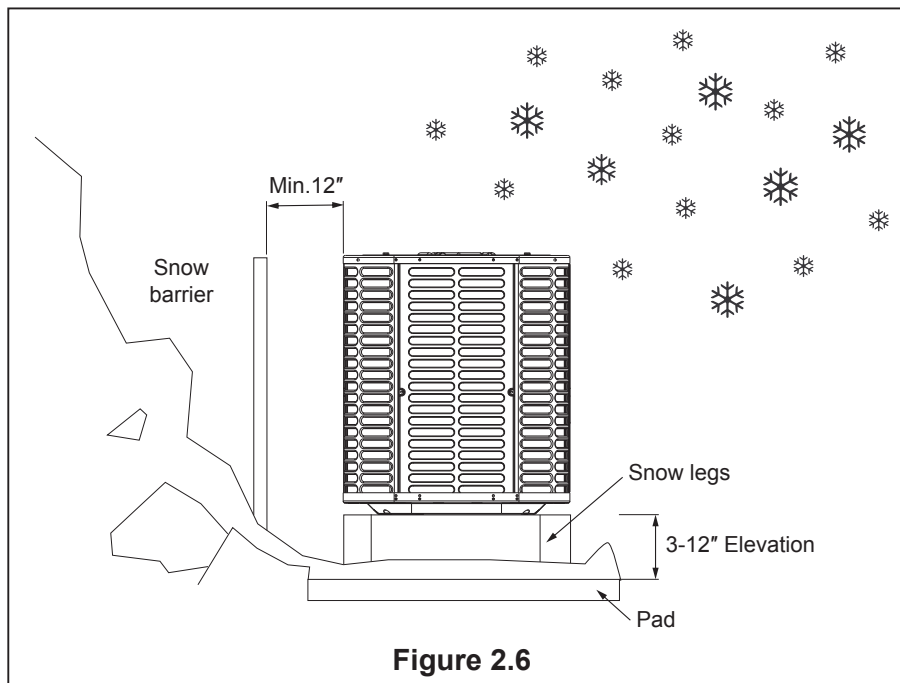

Corrosive Environment

Exposure to corrosive environment may shorten the service life of unit, corrode metal parts and/or negatively affect the performance of unit. Corrosive elements include but are not limited to: sodium chloride, sodium hydroxide, sodium sulfate and other compounds commonly found in seawater, sulfur, chlorine, fluorine, fertilizers and various chemical pollutants from industrial/manufacturing plants. If it is installed in an area that may be exposed to corrosive environment, special attention should be paid to the placement and maintenance of the unit.

- Lawn sprinklers/hoses/waste water should not be sprayed directly on the outer panel of the unit for a long time.
- In coastal areas: install the unit on the side away from the waterfront.
- Fences or shrubs can provide some shielding protection for the unit, but the minimum device clearance must still be kept.
- Clean the outdoor coil and any exposed external surfaces about every three months.

3. Unit Installation Preparation

3.1 Prepare the Unit for Installation

- Check whether there is any damage and report any damage to the unit to the carrier in time (Figure 3.1).
- The charge port can be used to ensure that the refrigerant charge is maintained during shipment.

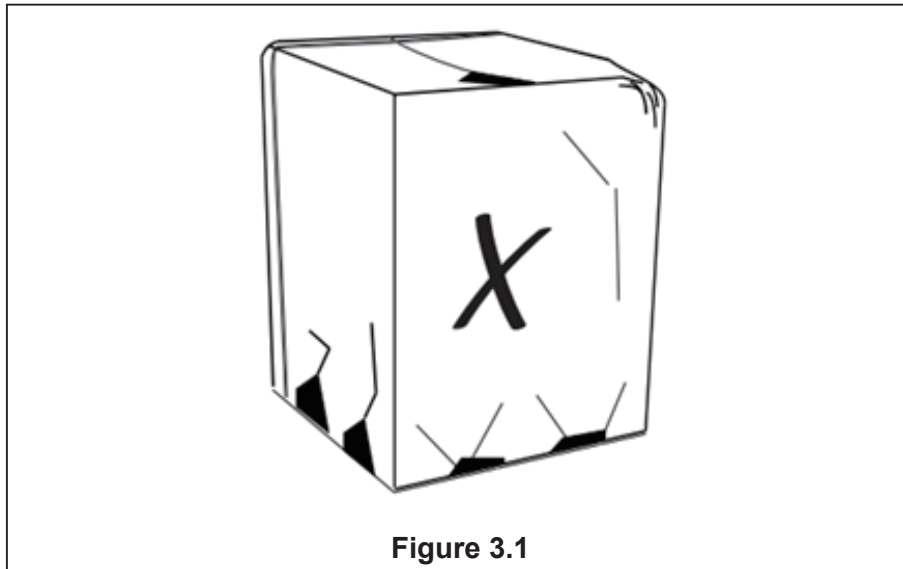

4. Unit Settings

4.1 Pad Installation

When installing the unit on a support pad (such as a concrete slab), please consider the following:

- All sides of the pad must be at least 1-2 inches larger than the unit.
- The pad must be separated from any structure.
- The pad must be level.
- The pad must be high enough above the ground for drainage.
- The location of the pad must comply with national, state and local regulations.



These instructions are intended to provide a method of fixing the system to the cement slab as a fixing procedure in windy areas. Check the local regulations of tie-down methods and protocols.

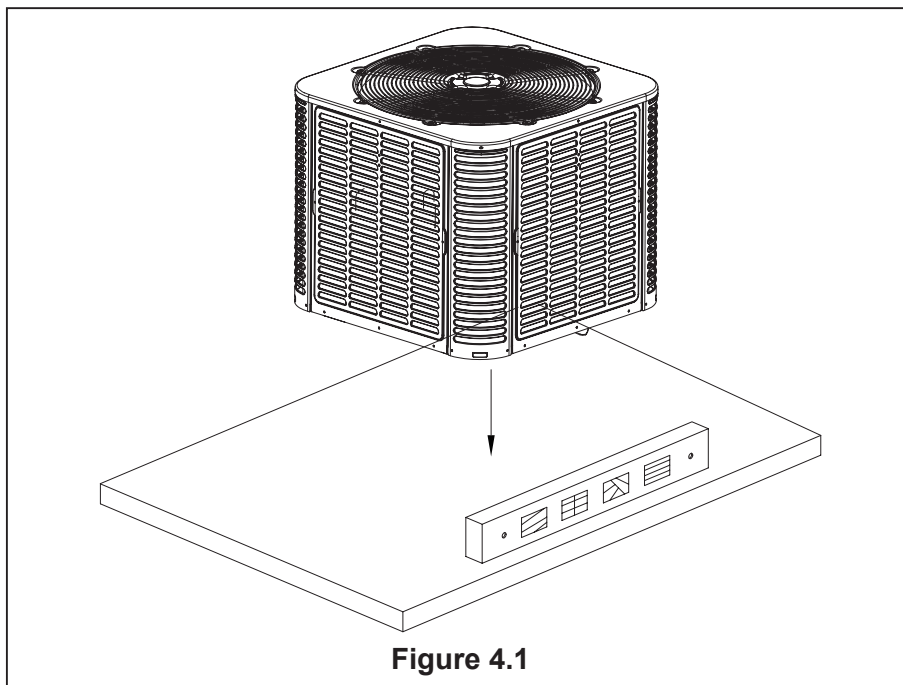

Figure 4.1

5. Precautions for Refrigerant Pipeline

5.1 Connecting Dimensions of Refrigerant Lines and Service Valves

Table 5.1

Model	Suction line	Liquid line	Suction line connection	Liquid line connection
	The dimensions are in inches.			
18K/24K/30K/36K	3/4	3/8	3/4	3/8

5.2 Required Refrigerant Line Length

Determine the required pipeline length (Figure 5.1). Please refer to Section 2.2.

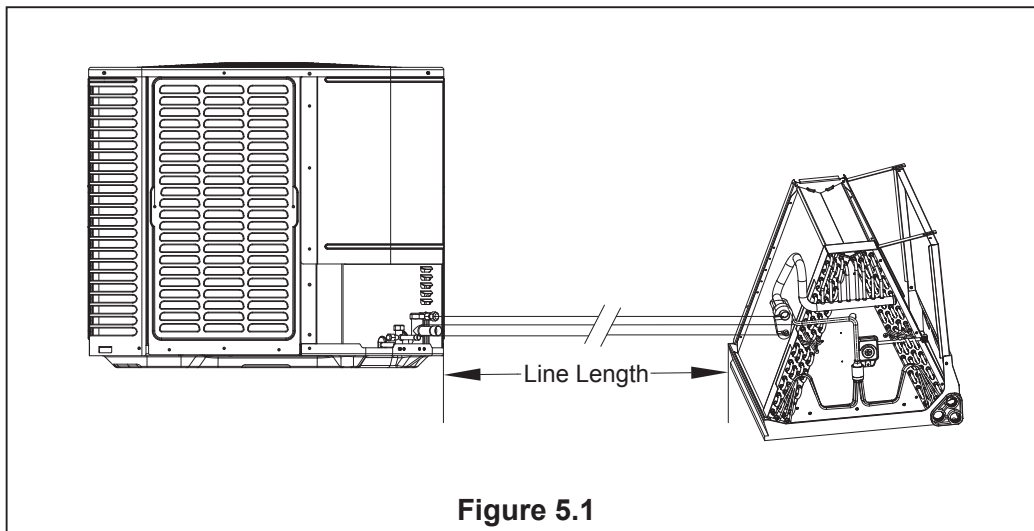

5.3 Refrigerant Pipe Insulation



The refrigerant pipe must always be insulated. Do not let the liquid line and suction line come into direct contact (metal to metal).

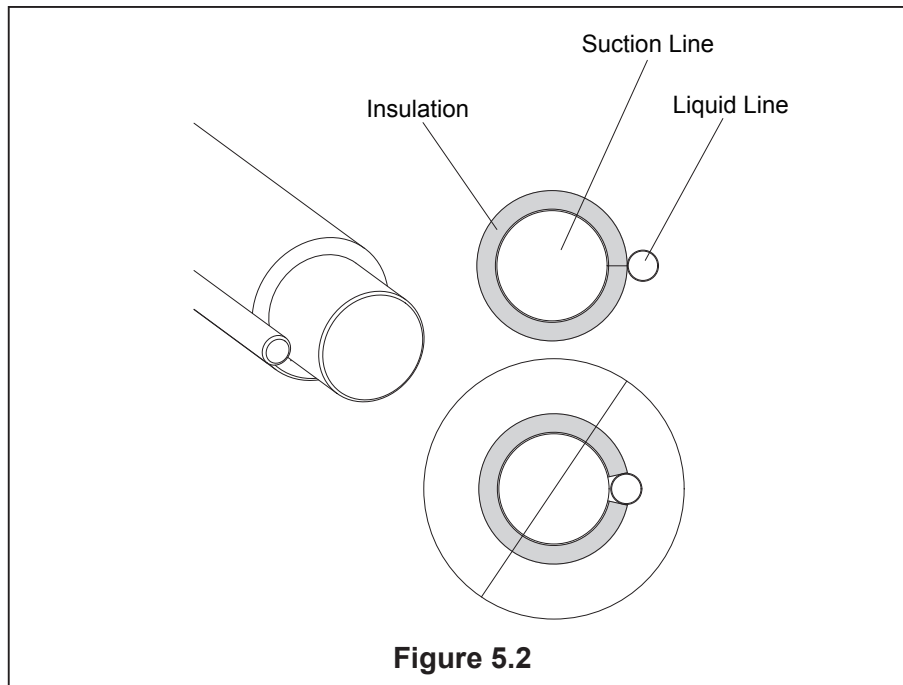

5.4 Reuse the Existing Refrigerant Lines



Note: Mild to moderate burns

- If using existing refrigerant lines, make sure that all joints are brazed, not soldered.

The following precautions should be taken for the retrofit application that will use the existing refrigerant pipeline:

- Make sure the refrigerant line size is correct. Refer to Section 2.2 and Table 2.2.
- Make sure the refrigerant line is free of leakage, acid and oil.



The manufacturer recommends that only approved matching indoor and outdoor systems be installed. All split systems of the manufacturer are AHRI-rated. The benefits of installing an approved indoor and outdoor split system are maximum efficiency, best performance and best overall system reliability.

6. Refrigerant Pipeline Routing

6.1 Preventive Measure

Take preventive measures to prevent noise generated by vibration transmission of refrigerant

line in building structure. For example:

- When the refrigerant line must be fixed on floor joists or other frames in the structure, use isolated hangers.
- When the refrigerant line runs in the column space or closed ceiling, the isolation hanger should also be used.
- When refrigerant lines pass through walls or windowsills, they should be insulated and isolated.
- Isolate the line from all ductwork systems.
- Try to reduce the number of 90° turn.



Comply with national, state and local regulations when isolating the wire group from joists, rafters, walls or other structural elements.

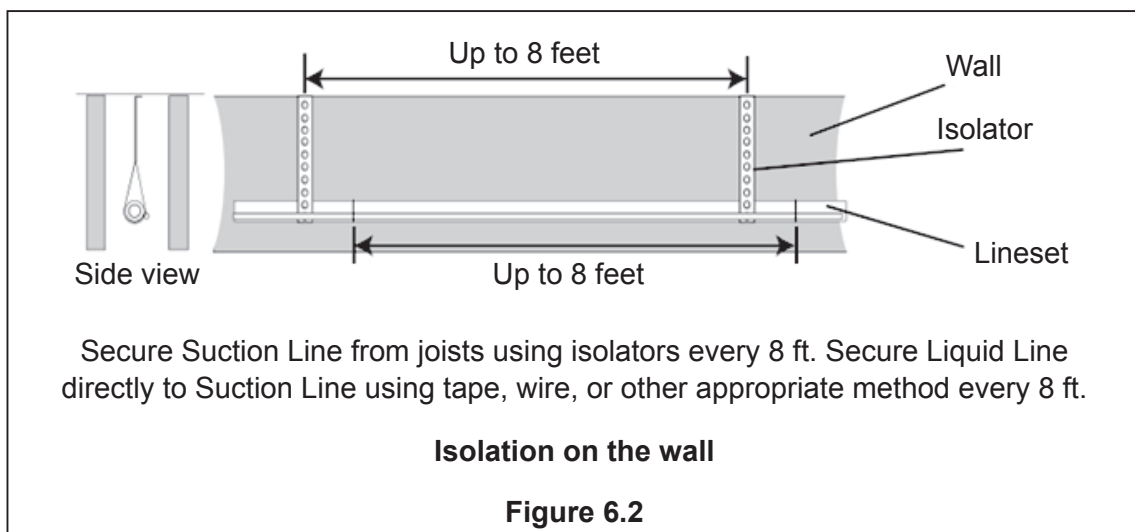
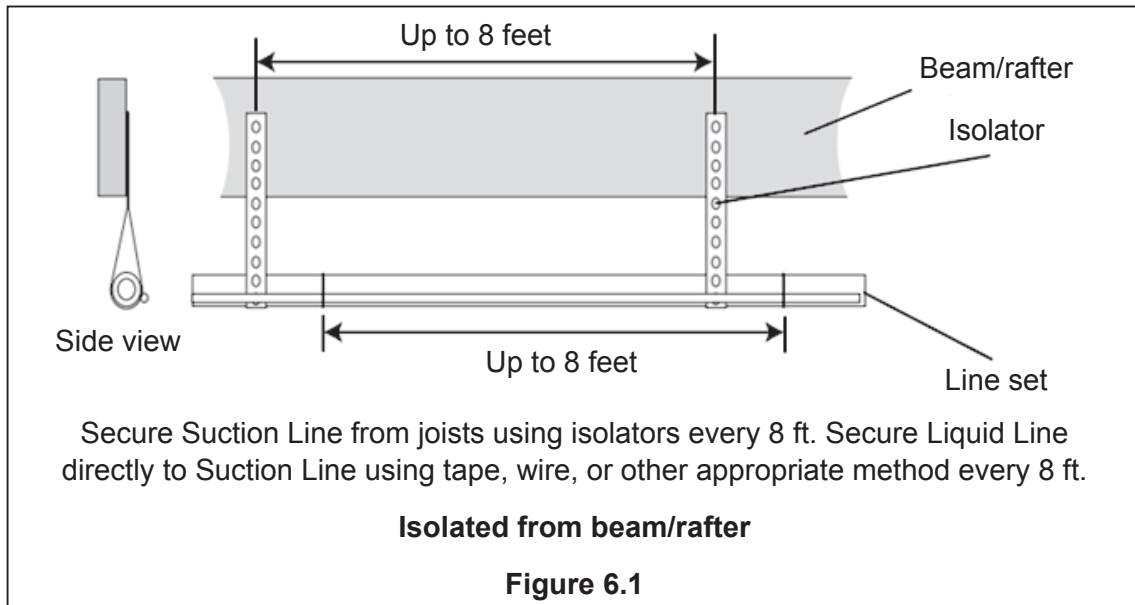

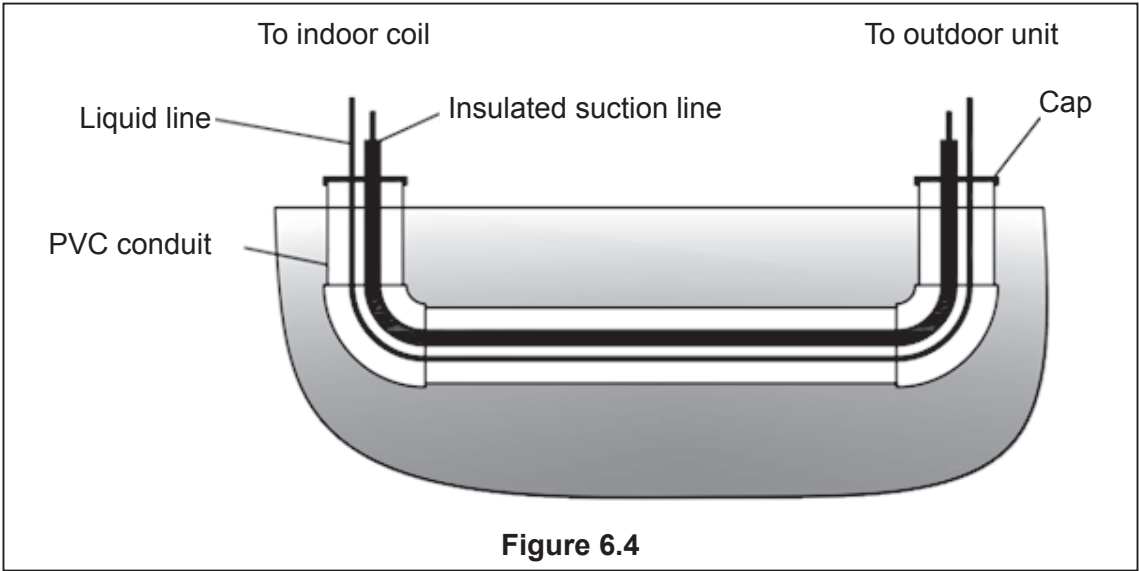
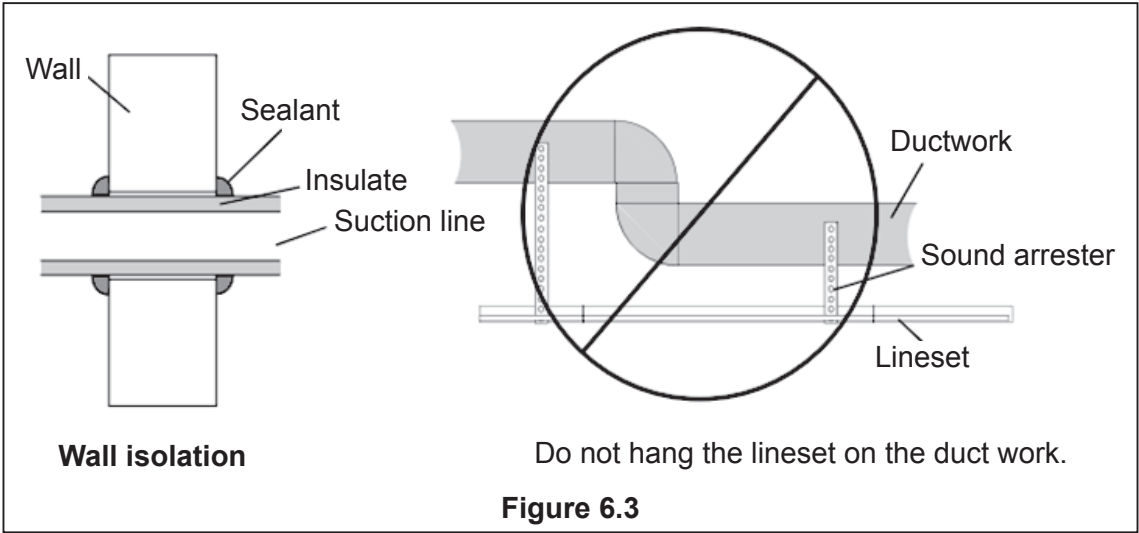

7. Refrigerant Line Brazing

7.1 Brazed Refrigerant Pipeline

1. Remove the cover or plug. Use the deburring tool to deburr the line end. Clean the inner and outer surfaces of the pipeline with emery cloth.

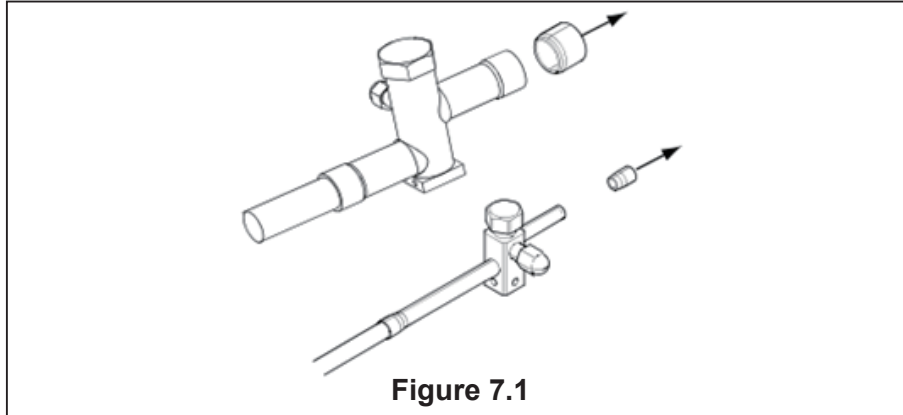

2. Remove the pressure taps from the two service valves.

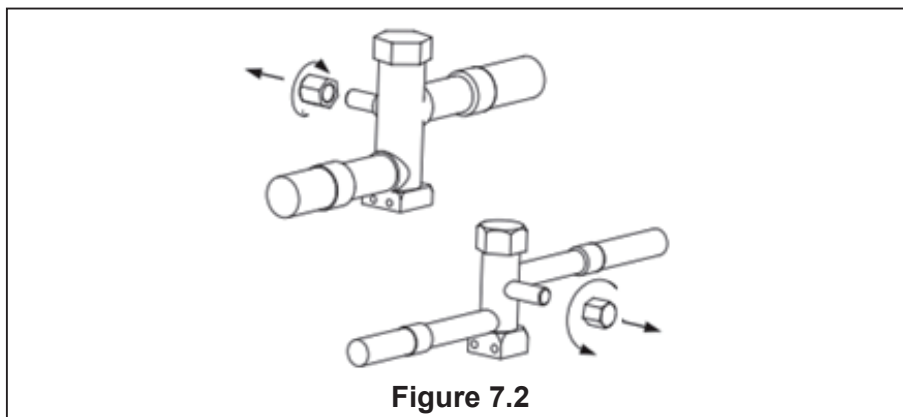

3. Purge refrigerant lines and indoor coils with dry nitrogen.

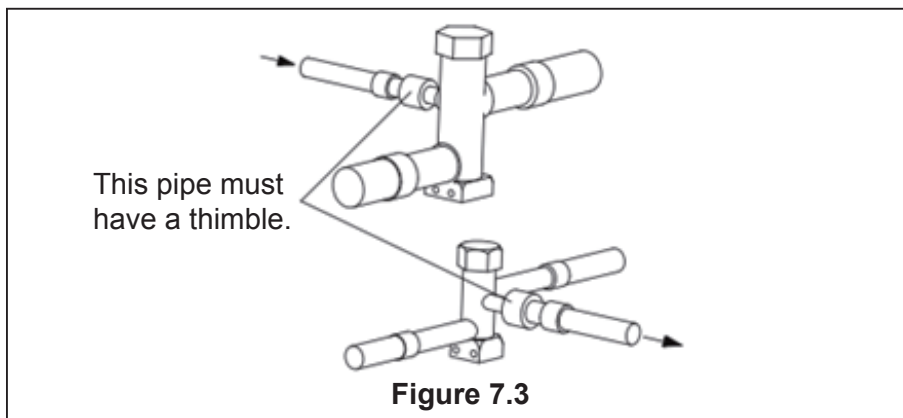

4. Wrap the valve body with a wet rag to avoid thermal damage, and continue the dry nitrogen purging (Figure 7.4).
Braze the refrigerant line to the service valve.
Braze the filter drier to the liquid line.



All units are recommended to install bidirectional filter driver. Braze the filter drier to the liquid line, taking care not to push the refrigerant line too hard through the stopper in the filter drier (this may damage the filter).

Continue the dry nitrogen purge. Don't take off the wet rag before all brazing is completed.



Before stopping the dry nitrogen purge, please remove the wet rag.

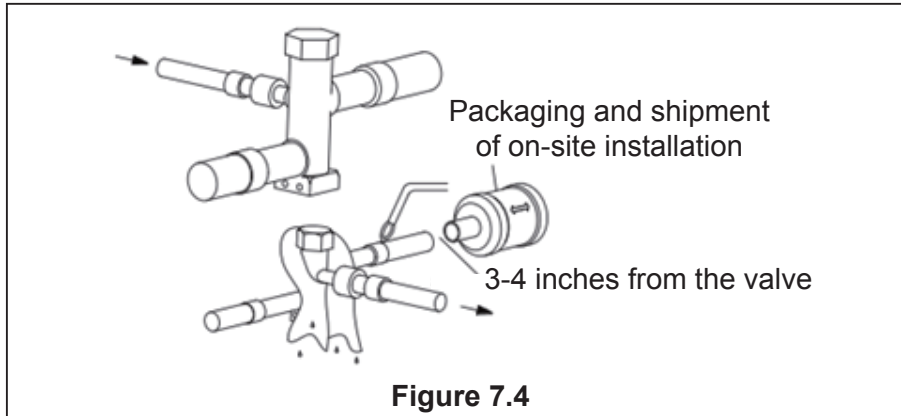

5. After the service valve cools down, put back the pressure tap.

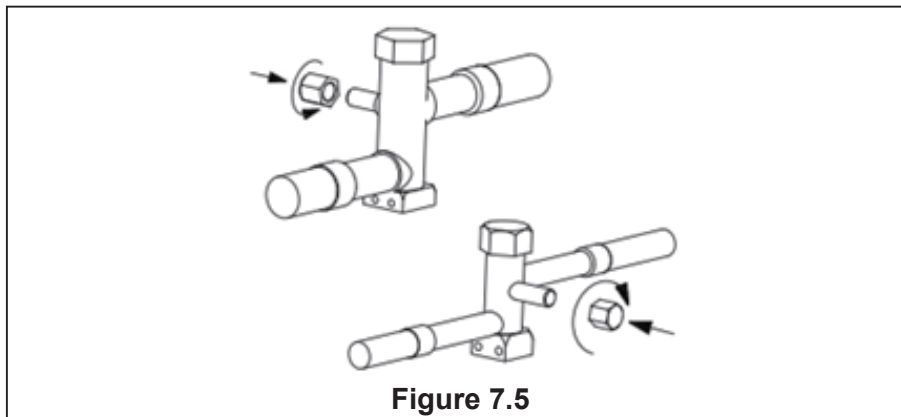

8. Refrigerant Line Leakage Inspection

8.1 Check for Leaks

1. Use dry nitrogen to pressurize the refrigerant line and evaporator coil to 250 PSIG*.

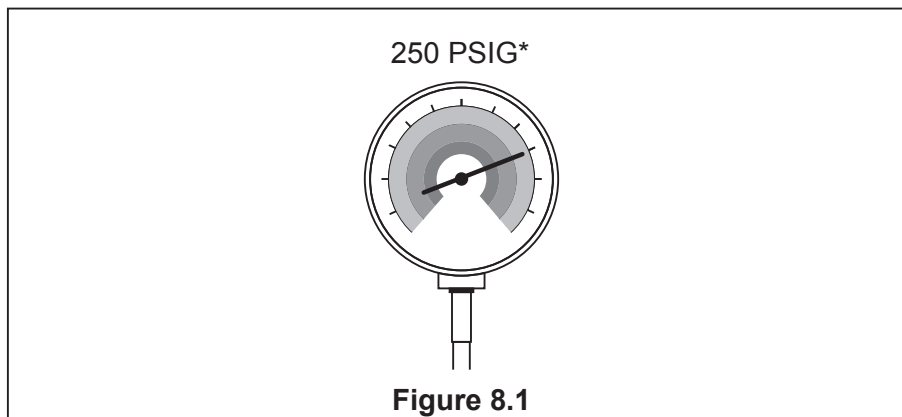

2. Use soapy water or bubbles at each brazing position to check for leaks.

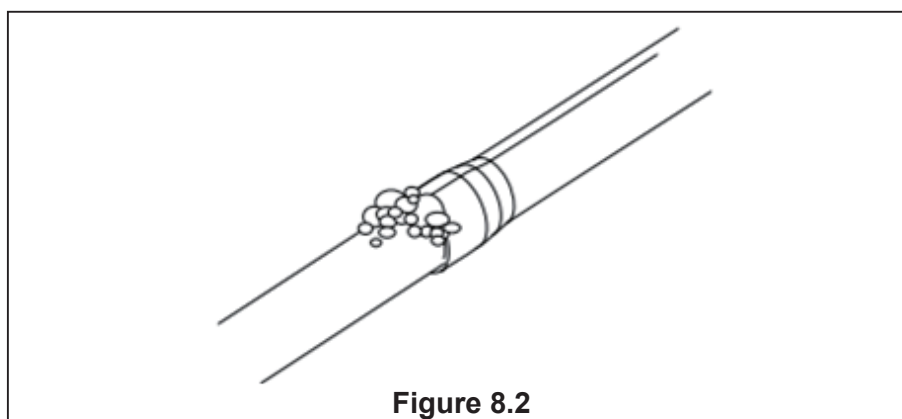

*Note:



- After completion of field piping for split systems, the field pipework shall be pressure tested with an inert gas and then vacuum tested prior to refrigerant charging. The minimum test pressure for the system shall be the low side design pressure (See nameplate for details).

9. Vacuuming

9.1 Drain Refrigerant Lines and Indoor Coils



Do not open the service valve until the leakage inspection and vacuuming of refrigerant lines and indoor coils are completed.

1. Evacuate until the micron gauge reads no higher than 350 microns, then close the valve to the vacuum pump.

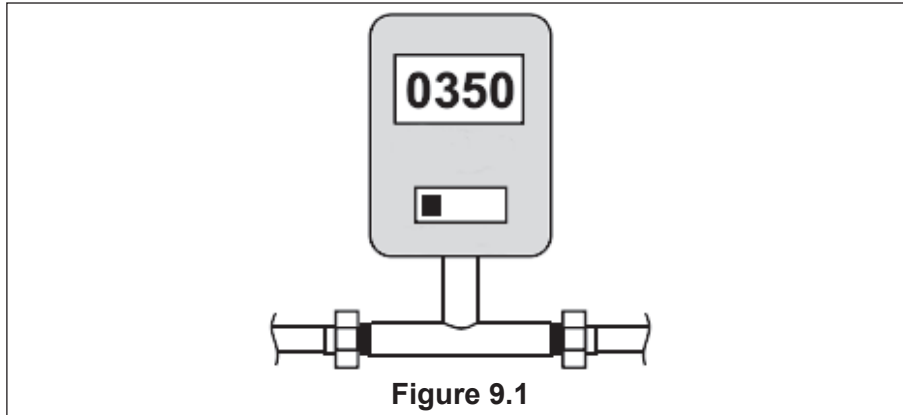

2. Observe micron gauge. If the micrometer meter does not rise above 500 microns within one (1) minute, the evacuation is completed.

After the evacuation, turn off the vacuum pump and micron gauge, and close the valve on the manifold instrument cluster.

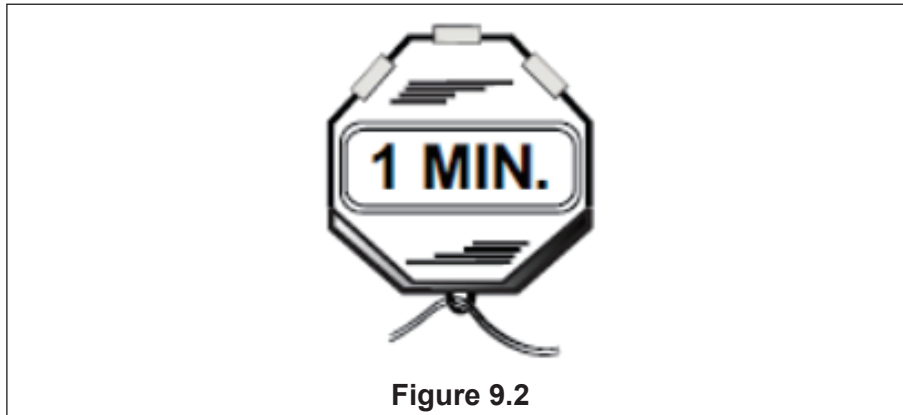

10. Service Valve

10.1 Open the Service Valve



Warning: Moderate to severe burns

- When opening the liquid line service valve, be extra careful. Turn counterclockwise until the valve stem just touches the hem. No torque is required. Failure to observe this warning will result in sudden release of system pressure, and may result in personal injury and/or property damage.



Before opening the service valve, the leakage inspection and evacuation must be completed. The valve of copper welded pipe installation should be used for leakage inspection and vacuum pumping. The use of a separate suction port in this process will lead to refrigerant loss.



Before opening the liquid service valve, the suction service valve must be opened first.

1. Remove the valve cover (Figure 10.1).
2. Insert the hex wrench into the valve stem completely and back out counterclockwise until the valve stem just touches the bead (about five (5) turns.)
3. Replace the valve stem cap to prevent leakage. Tighten it with your fingers and turn it for another 1/6 turn.
4. Repeat steps 1-3 for the liquid service valve.

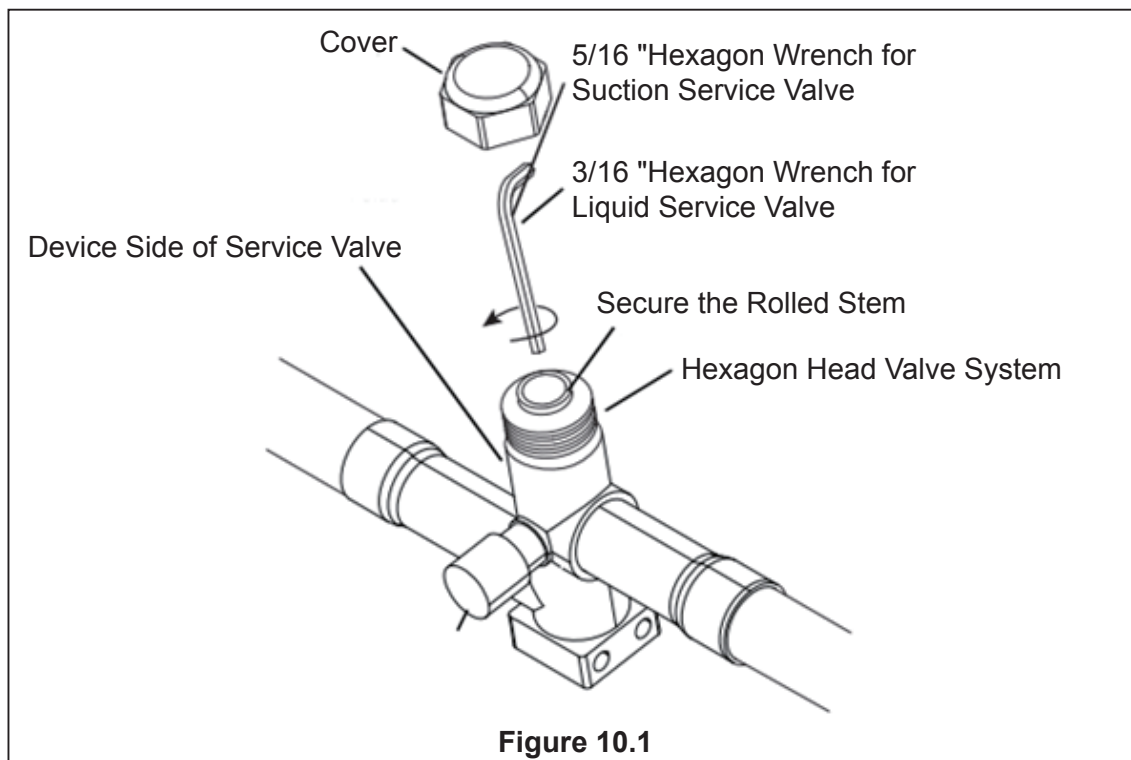

11. Electrical-Low Voltage

11.1 Low Voltage Connection Diagram

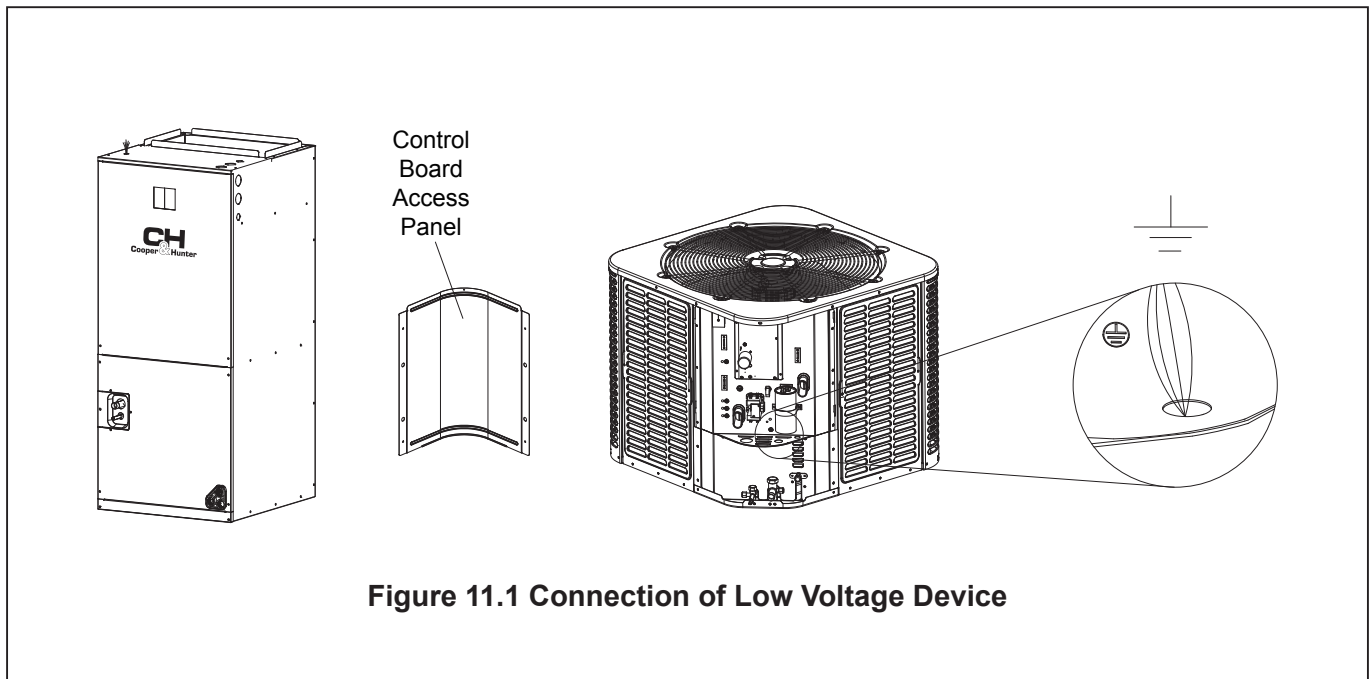

11.2 Wiring Diagram of Thermostat

- Ensure that the power supply is consistent with the nameplate of the unit.
- The power connection and grounding of the unit must comply with local regulations.
- Low voltage wiring to be No. 22 AWG minimum conductor.
- "-----" On-site installation of electrical auxiliary heat connection
- Single-stage electric auxiliary heating supported by 2H thermostat
- Two-stage electric auxiliary heating supported by 3H thermostat
- W1: The first stage of electric auxiliary heating installed in the indoor unit.
- W2: The second stage of electric auxiliary heating installed in the indoor unit.
- The W signal of the outdoor unit is connected to the electric auxiliary heating or the first-stage electric auxiliary heat.



The dotted line in the following thermostat wiring diagram indicates optional wiring (wiring for passive dehumidification and/or electric heating). For the wiring of the thermostat, please refer to the user manual of the thermostat.



The reversing valve is energized in heating mode and de-energized in cooling mode. As factory default, O/B terminal and reversing valve are set to be energized at the same time.

Wiring for 3H and 2C thermostat

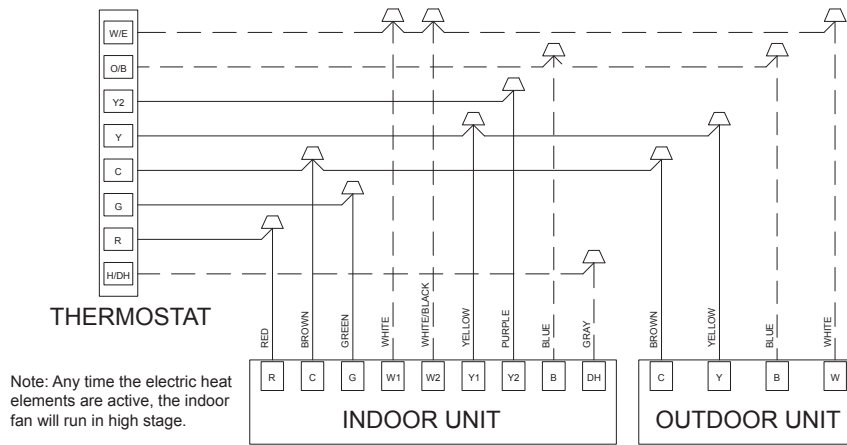

Figure 11.2 Control Wiring

Wiring for 4H and 2C thermostat

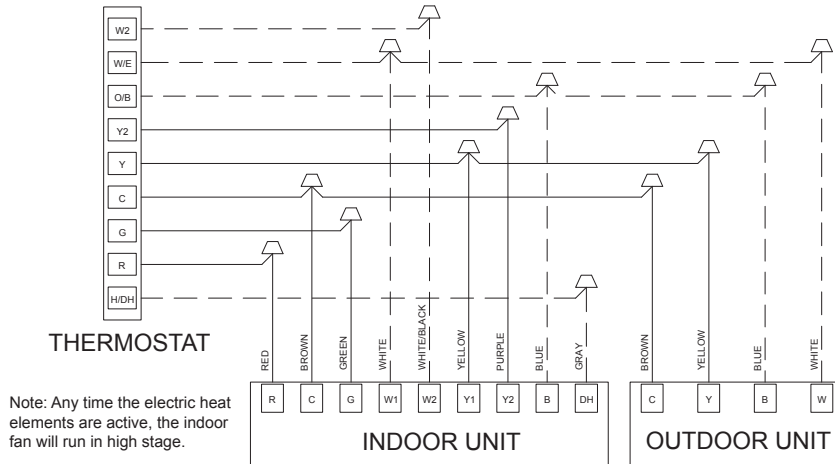

Figure 11.3 Control Wiring

Wiring for 3H and 1C thermostat

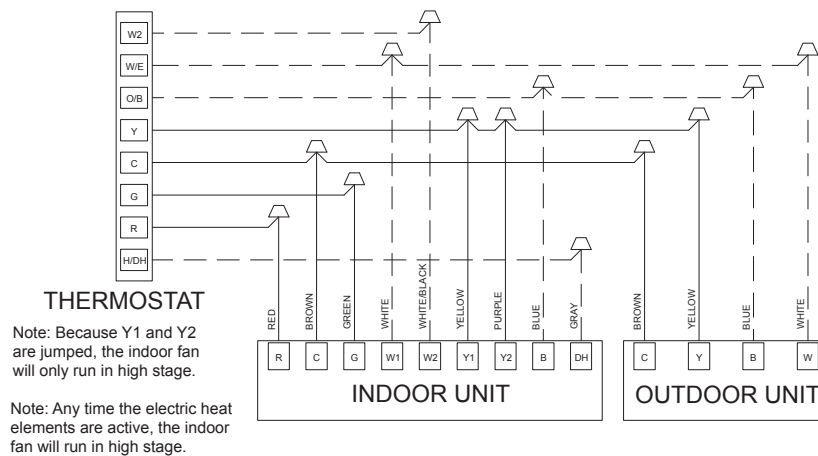

Figure 11.4 Control Wiring

Wiring for 2H and 2C thermostat

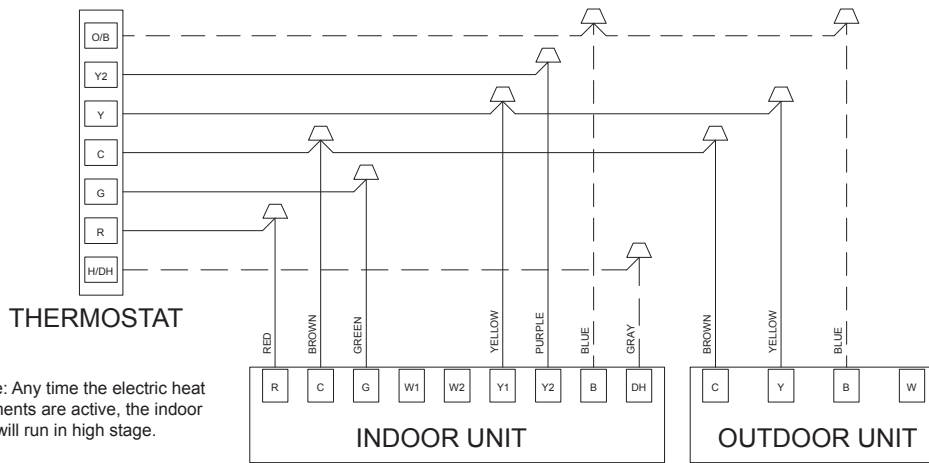

Figure 11.5 Control Wiring

Wiring for 1H and 1C thermostat

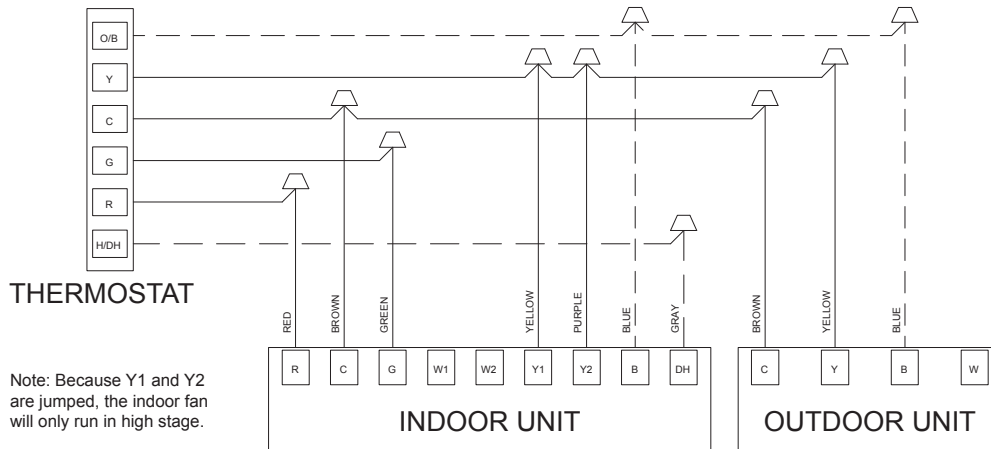

Figure 11.6 Control Wiring

Wiring for 2H and 1C thermostat

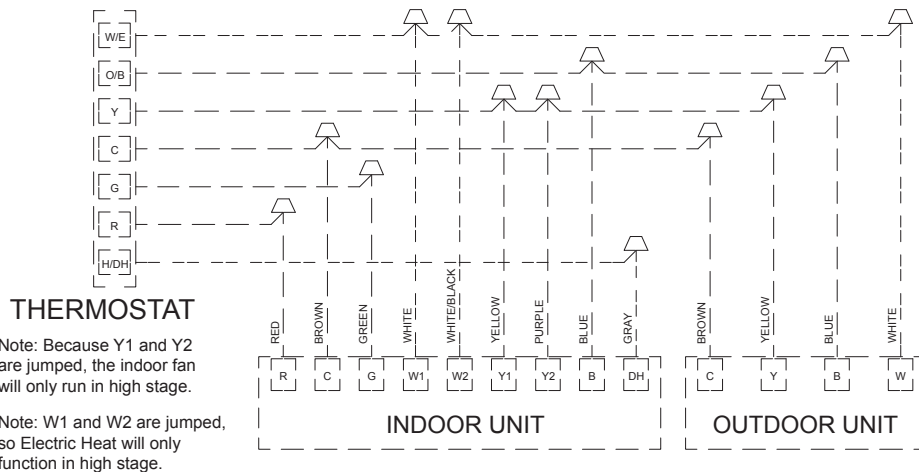

Figure 11.7 Control Wiring

12. Electrical-High Voltage

12.1 High Voltage Power Supply



Warning: Live electrical parts!

- During the installation, testing, maintenance and troubleshooting of this product, it may be necessary to use live electrical parts. Failure to observe all electrical safety precautions when exposed to live electrical parts may result in death or serious injury.

The high-voltage power supply must match the nameplate of the unit (208/230V, 1Ph, 60Hz).

The operating range is 187V~253V, if the power supply is unstable and fluctuated, a Surge Protection Device (SPD) or Hard Start Kit should be installed.



Power supply wiring must comply with national, state and local regulations.

Follow the instructions of the unit wiring diagram located at the back side of control box access panel, and refer to the wiring diagram in this installation manual.

12.2 High Voltage Disconnect Switch

Install a separate disconnect switch on the outdoor unit.

High-voltage wiring must use flexible electrical conduit supplied on site.

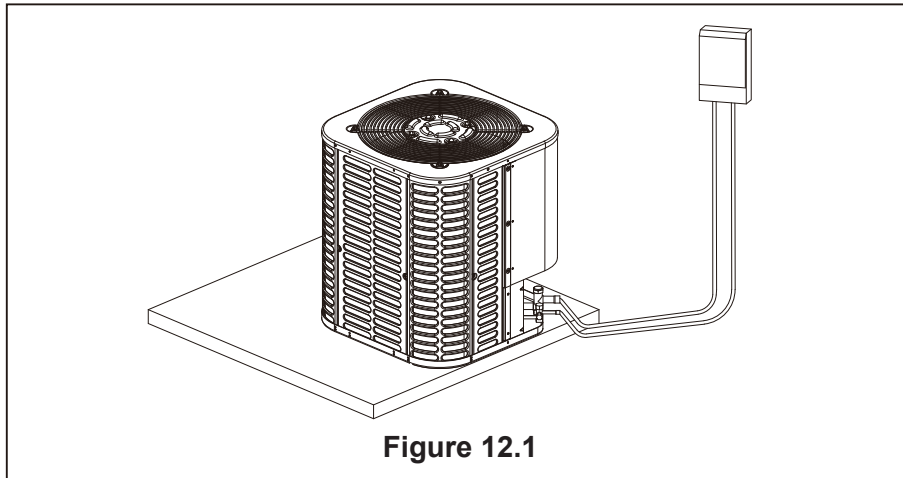

Figure 12.1

12.3 High Voltage Grounding

Ground the outdoor unit according to the requirements of national, state and local regulations.

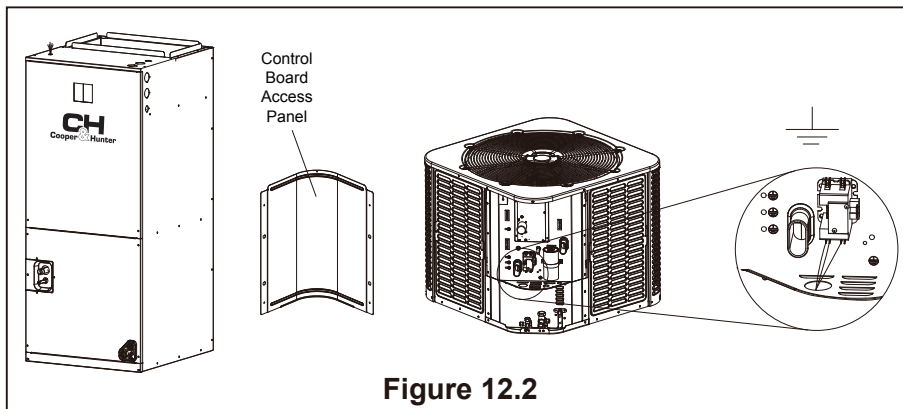

Figure 12.2

Table 12.1 Wire gauge of high voltage system

Type (Btu/ hour)		18K	24K	30K	36K	
Power	Phase	Single				
	Voltage/frequency	208/230VAC, 60 Hz				
Wire gauge	Indoor unit power cord	Line quantity	3	3	3	3
		Wire diameter (AWG)	16	16	16	16
	Outdoor unit power cord	Line quantity	3	3	3	3
		Wire diameter (AWG)	14	12	12	10

13. Start

13.1 System Startup

1. Make sure that Step 7, 8, 9, 10, 11 and 12 have been completed.
2. Set the system thermostat to off.

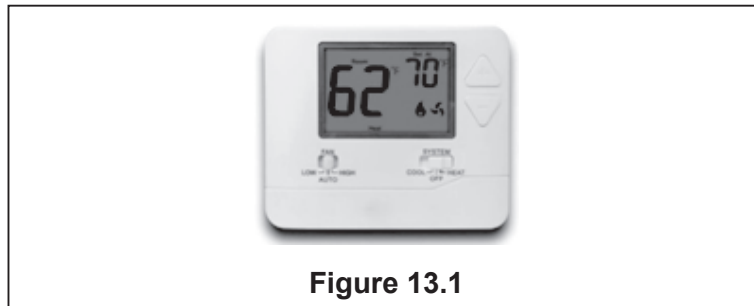

Figure 13.1

3. Turn on the disconnect switch and apply power to indoor unit and outdoor unit.

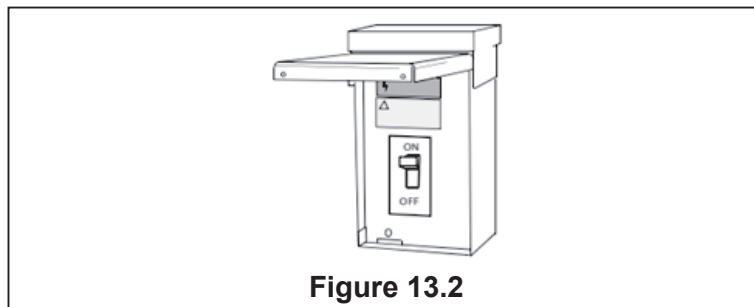

Figure 13.2

4. Set the system thermostat to ON.

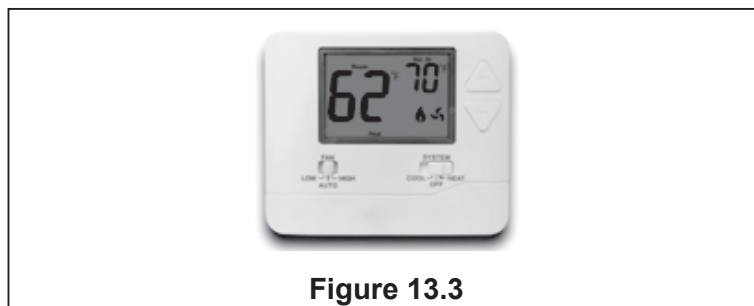

Figure 13.3

14. System Refrigerant Charging Method

14.1 Refrigerant Charging: Weigh-In Method

Use weigh-in method the initial installation, or anytime a system charge is being replaced. Weigh-in method can also be used when power is not available to the equipment site or operating conditions (indoor/outdoor temperatures) are not in range to verify with the subcooling charging method.



The factory charge in the outdoor unit is sufficient for 4.57m (15ft) of standard size inter-connecting liquid line. Additional 44g/m (0.47 oz/ft) refrigerant is needed when length of lineset is more than 4.57m (15ft).

New Installations — Calculating additional charge for lineset greater than 4.57m (15ft).

1. Total length of line (ft) = _____(a)
 2. Standard line setup (ft) = 4.57m (15ft) (b)
 3. (a) minus (b) = _____(c)
 4. Refrigerant multiplier = 44g/m (0.47 oz/ft) (d)
 5. Additional refrigerant quantity (c*d) = _____(e)*
- * If the line set is less than 4.57m (15ft), e = 0

Sealed-System Repairs — Calculating total system charge.

1. Total length of line (ft) = _____(a)
 2. Standard line setup (ft) = 4.57m (15ft) (b)
 3. (a) minus (b) = _____(c)
 4. Refrigerant multiplier = 44g/m (0.47 oz/ft) (d)
 5. Additional refrigerant quantity (c*d) = _____(e)*
 6. Factory filling quantity (nameplate) = _____(f)
 7. Total system charge (e + f) = _____
- * If the line set is less than 4.57m (15ft), e = 0



The only mode approved for verifying system charging is in "cooling mode".

You can refer to the above formula for calculation, or you can choose the appropriate refrigerant addition according to the piping length.

Table 14.1 Additional Refrigerant Guidelines

Piping length (ft)/(m)	Additional charge (oz)/(kg)
15/4.57	0
25/7.62	4.73/0.13
75/22.86	28.39/0.80
100/30.48	40.21/1.14
131/39.93	54.88/1.56

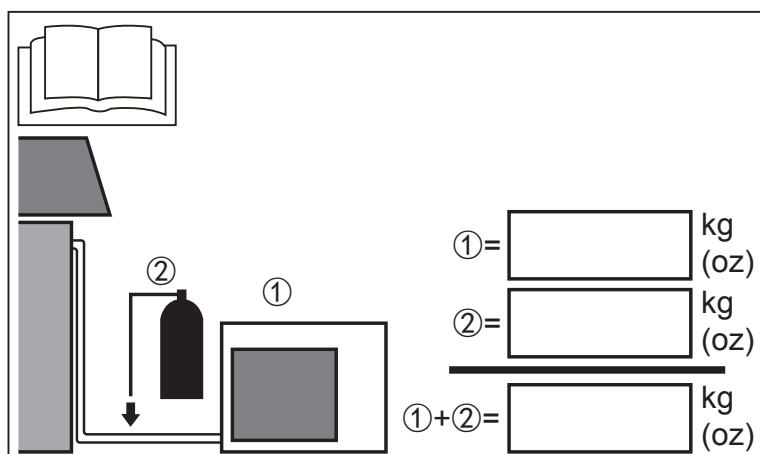

- ① REFRIGERANT CHARGE of the precharged part of the appliance
- ② REFRIGERANT CHARGE added during installation

14.2 Charging and Refrigerant Adjustment in Cooling Mode

Check the outdoor ambient temperature

Check the ambient temperature. Subcooling method (cooling mode) is only for outdoor temperature between 57°F and 118°F, and indoor temperature between 68°F and 89°F. For temperature out of the range, use the weigh-in method mentioned above.

Subcooling Method (For TXV Match-Ups)

Calculate subcooling value. Calculate subcooling value with measured liquid line temperature and pressure according to Table 14.2. If calculated subcooling value is lower than the design subcooling value of Table 14.4, refrigerant should be added. If calculated subcooling value is higher than the value of Table 14.4, refrigerant should be recovered.

Superheat Method

Calculate superheat value. Calculate superheat value with measured vapor line temperature and pressure according to Table 14.3. If calculated superheat value is lower than the design superheat value of Table 14.5, refrigerant should be recovered. If calculated superheat value is higher than the value of Table 14.5, refrigerant should be added.

Table 14.2

Liquid Line Temperature (°F)	Subcooling Value (°F)							
	6	7	8	9	10	11	12	13
	Liquid Gauge Pressure (PSI)							
55	177	180	183	186	189	193	196	199
60	193	196	199	202	206	209	213	216
65	209	213	216	220	223	227	230	234
70	227	230	234	238	241	245	249	253
75	245	249	253	257	261	265	269	273
80	265	269	273	277	281	286	290	294
85	286	290	294	299	303	307	312	316
90	307	312	316	321	326	330	335	340
95	330	335	340	345	350	355	360	365
100	355	360	365	370	375	380	385	391
105	380	385	391	396	401	407	412	418
110	407	412	418	424	429	435	441	447
115	435	441	447	453	459	465	471	477
120	465	471	477	483	489	496	502	509
125	496	502	509	515	522	528	535	542

Table 14.3

Suction Temp (°F)	Superheat Value (°F)								
	6	8	10	12	14	16	18	20	22
	Suction Gauge Pressure (PSI)								
40	107	103	99	95	91	87	84	80	77
42	112	107	103	99	95	91	87	84	80
44	116	112	107	103	99	95	91	87	84
46	121	116	112	107	103	99	95	91	87
48	126	121	116	112	107	103	99	95	91
50	131	126	121	116	112	107	103	99	95
52	136	131	126	121	116	112	107	103	99
54	141	136	131	126	121	116	112	107	103
56	146	141	136	131	126	121	116	112	107
58	151	146	141	136	131	126	121	116	112
60	157	151	146	141	136	131	126	121	116
62	162	157	151	146	141	136	131	126	121
64	168	162	157	151	146	141	136	131	126
66	174	168	162	157	151	146	141	136	131
68	180	174	168	162	157	151	146	141	136
70	186	180	174	168	162	157	151	146	141
72	193	186	180	174	168	162	157	151	146

Table 14.4

Subcooling (°F)	Ambient Temperature (°F)				
	57~77	77~86	86~95	95~104	104~118
	4±2	3±2	2±1	2±1	2±1

Table 14.5 *

Outdoor DB (°F)	Indoor DB/WB (°F)				
	90/75	85/71	80/67	75/63	70/58
110	8±2	8±2	5±2	5±2	5±2
100	10±2	9±2	7±2	5±2	5±2
90	10±2	9±2	8±2	5±2	5±2
80	12±2	10±2	7±2	7±2	5±2
70	10±2	8±2	8±2	5±2	5±2
60	9±2	7±2	5±2	5±2	5±2

* For 30K/36K, add 6 of superheat.

15. System Operation and Troubleshooting

15.1 Control Logic Description

- The system is using universal 24V control.

15.2 Sensors and valves

- T3- Outdoor unit coil temperature(Table 15.2)
- T4- Ambient temperature(Table 15.2)
- T5- Compressor exhaust temperature(Table 15.3)
- TH- Compressor suction temperature(Table 15.2)
- HP- High pressure switch
- LP- Low pressure switch

15.3 Defrost Description (Heat pump)

- Automatic Defrost Control Function.

The outdoor unit will enter defrost mode automatically according to T3 temperature.

- Fixed Time Defrost.

When the dip switch SW2-2 is set to ON, the Fixed Time Defrost Mode is activated while the SW2-3 offers different fixed time options. SW2-2 and SW2-3 are set to OFF by default.

- Manual Defrost.

The outdoor unit will enter defrost mode automatically When the dip switch SW2-1 is set to ON.

15.4 Compressor Crankshaft Heater Control Function (Optional)

The outdoor unit will Automatically turn on and off the crankshaft heating belt function according to the T5 temperature.

15.5 Operation of Reversing Valve

- ▶ The reversing valve is energized in heating mode and de-energized in cooling mode.



During the heating signal of the first operation, the unit will run in the cooling state for about 5 s, accumulating pressure for reversing the reversing valve.

15.6 Defensive Function

- Temperature protection of outdoor coil in cooling mode (T3)

1. If $T3 >$ Maximum set temperature, the system stops for protection.
2. If $T3 <$ the set recovery temperature value, the system restarts.

Note: Please consult the supplier for maximum temperature and recovery temperature.

- Compressor discharge temperature protection (T5)

1. In cooling or heating mode, if the temperature is higher than the set maximum value, the system will stop for protection.
2. In cooling or heating mode, if the temperature is lower than the set recovery temperature, the system will restart.

Note: Please consult the supplier for maximum temperature and recovery temperature.

Please consult the supplier for specific values.

- Temperature protection of outdoor coil in cooling mode (TH)
 1. If TH > Maximum set temperature, the system stops for protection.
 2. If TH < the set recovery temperature value, the system restarts.

Note: Please consult the supplier for maximum temperature and recovery temperature.

15.7 SW1 DIP SWITCH Description

- The dip switch SW1-1 and SW1-2 are determined by different model.
- The dip switch SW2 offers different defrost mode options(Heat pump).

Model	Speed	SW1-1	SW1-2
/	850	OFF	ON
18K/24K/30K/36K	950	OFF	OFF
/	1050	ON	OFF
/	1100	ON	ON

Dial	SW1-3	SW1-4
ON	Reserved	Reserved
OFF	Reserved	Reserved

Dial	SW2-1	SW2-2	SW2-3	SW2-4
ON	Manual defrost mode	Fixed time defrost mode	30 Min	Reserved
OFF	- (Default)	Automatic defrost mode(Default)	60 Min(Default)	Reserved

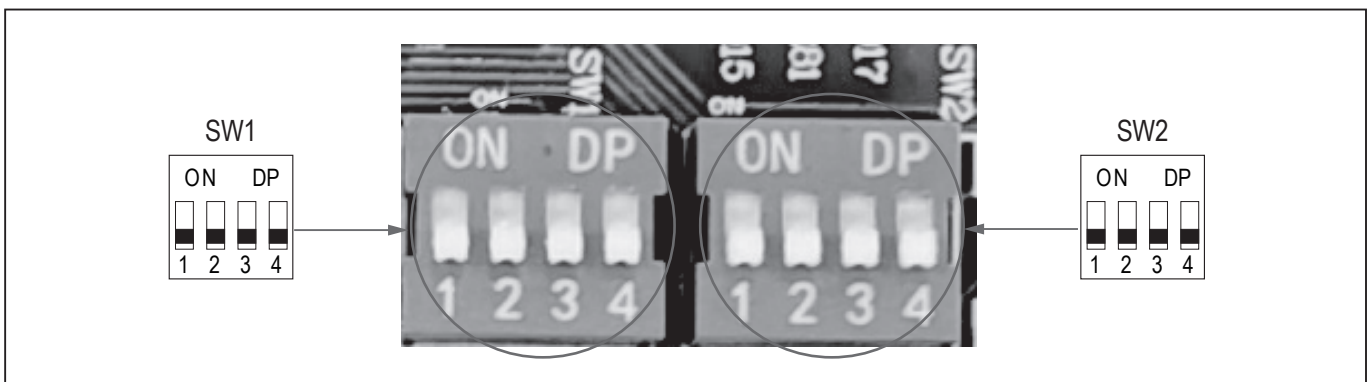

15.8 Overview of Main Control Board

Outdoor Main Control Board

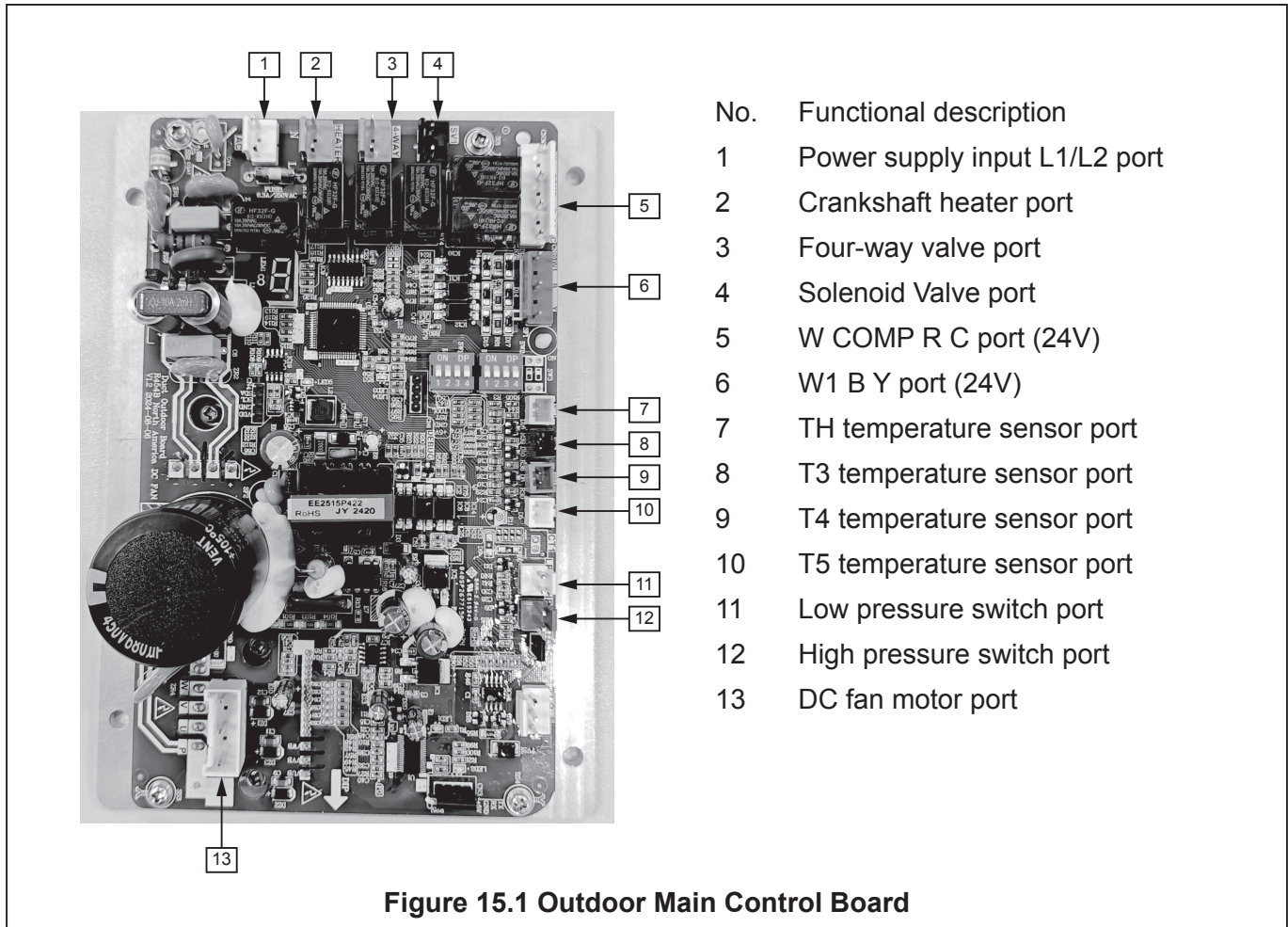

15.9 Troubleshooting of Fault Codes



Warning: Dangerous voltage

- When measuring the resistance, make sure that the power of the unit is turned off and wait for 3 minutes at least before measuring.

Table 15.1 Digital tube displays fault code

	Digital tube display content	System status
Model	0	Standby Mode
	1	Cooling Mode
	2	Heating Mode
System warning	3	T3 Sensor Error
	4	T4 Sensor Error
	5	T5 Sensor Error
	6	Low Pressure Protection
	7	High Pressure Protection
	8	Outdoor Fan Error
	9	T3 High Temperature Protection
	A	T4 Ambient Temperature Protection
	C	T5 High Compressor Discharge Temperature Protection
	E	TH Sensor Error
	F	TH Anti-freezed Protection
System lock	L	Low Voltage Protection
	6.	6 times Low Pressure Protection within 60 minutes
	7.	6 times High Pressure Protection within 60 minutes
	8.	4 times Outdoor Fan Error within 60 minutes
	C.	3 times High Compressor Discharge Temperature Protection within 60 minutes
	L.	2 times Low Voltage Protection within 120 minutes

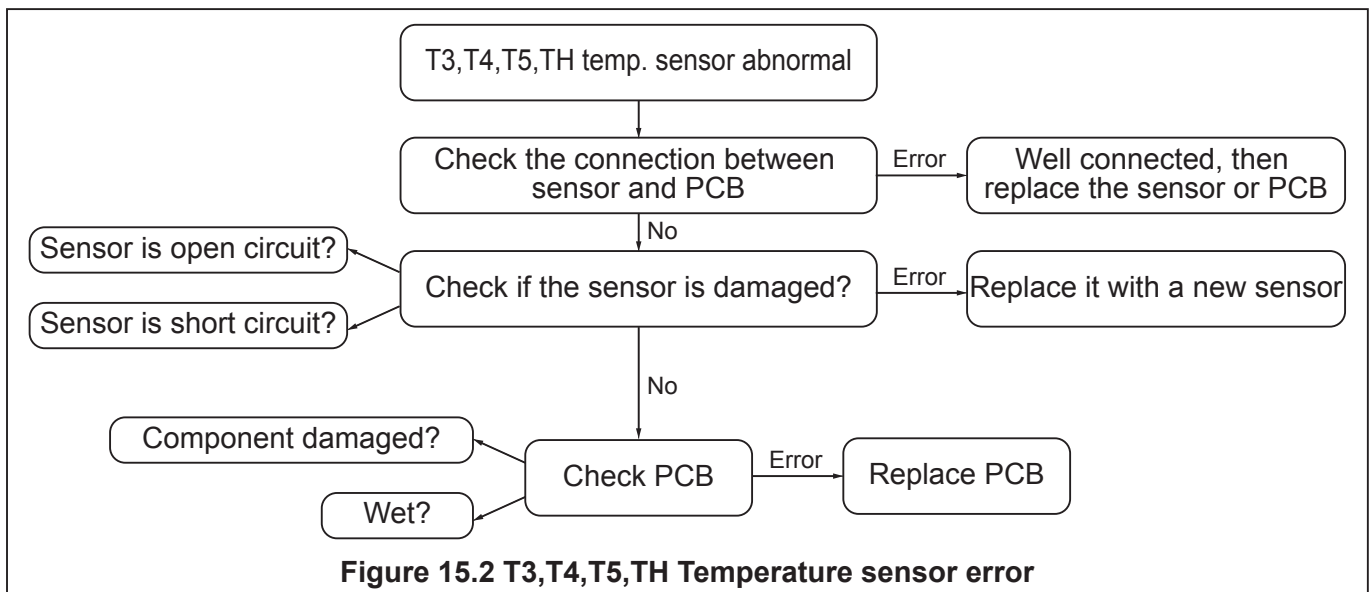

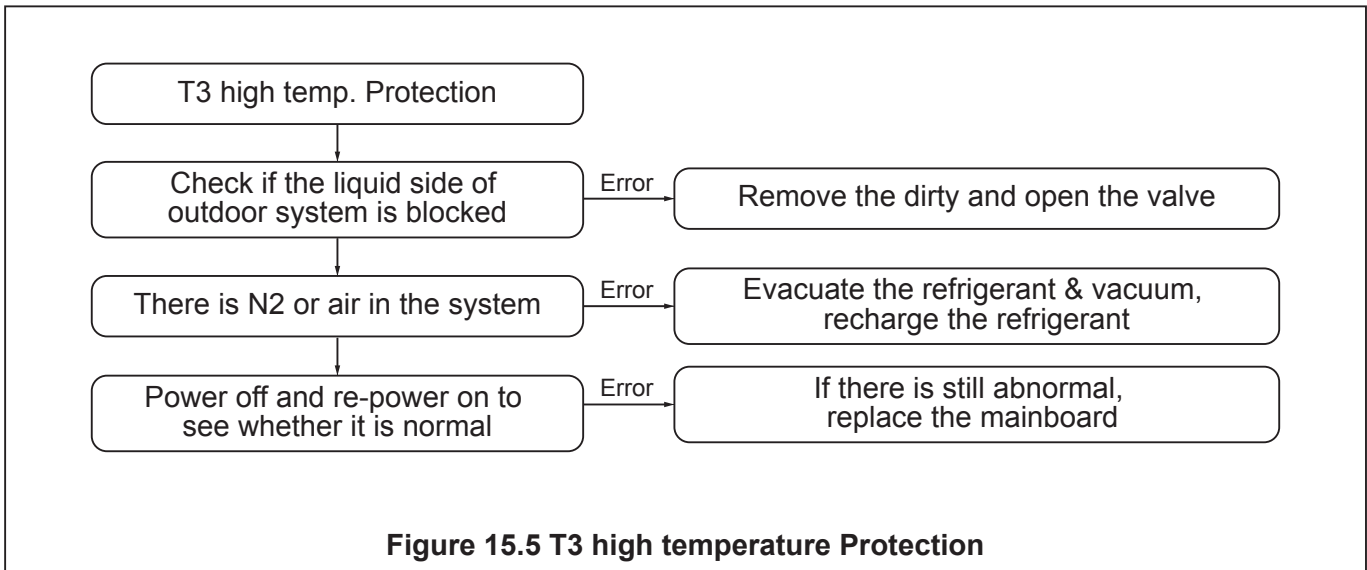
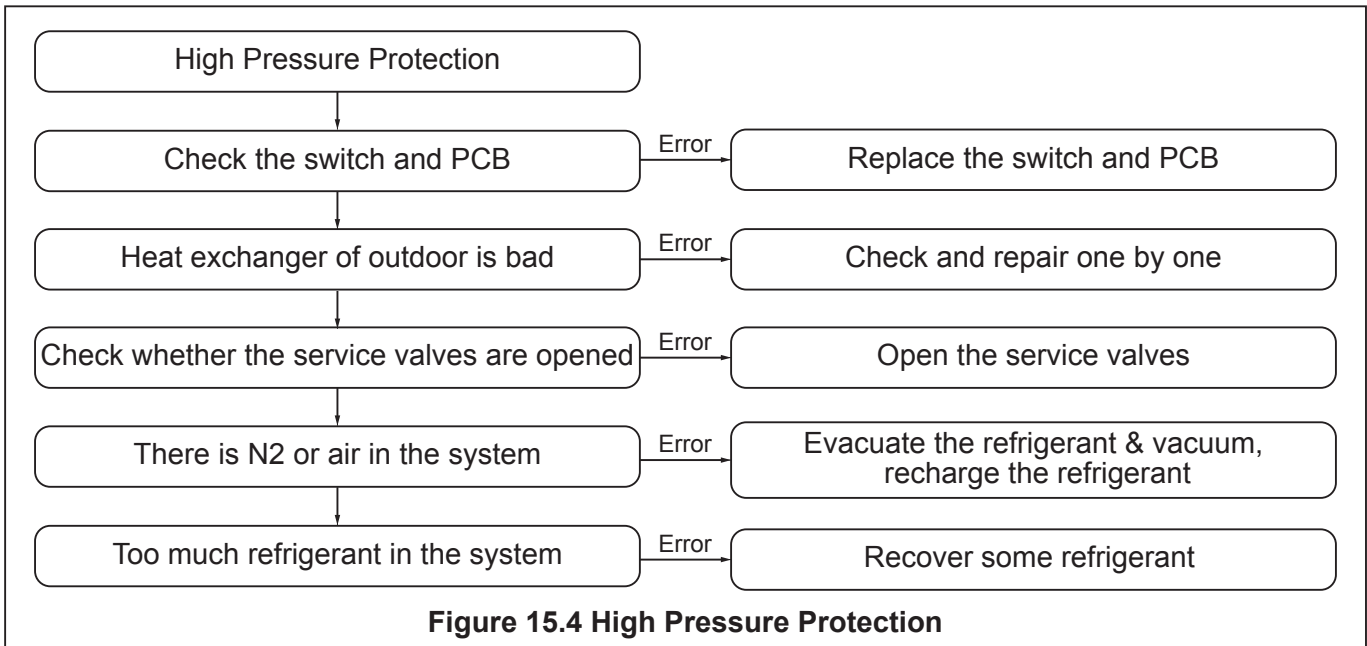
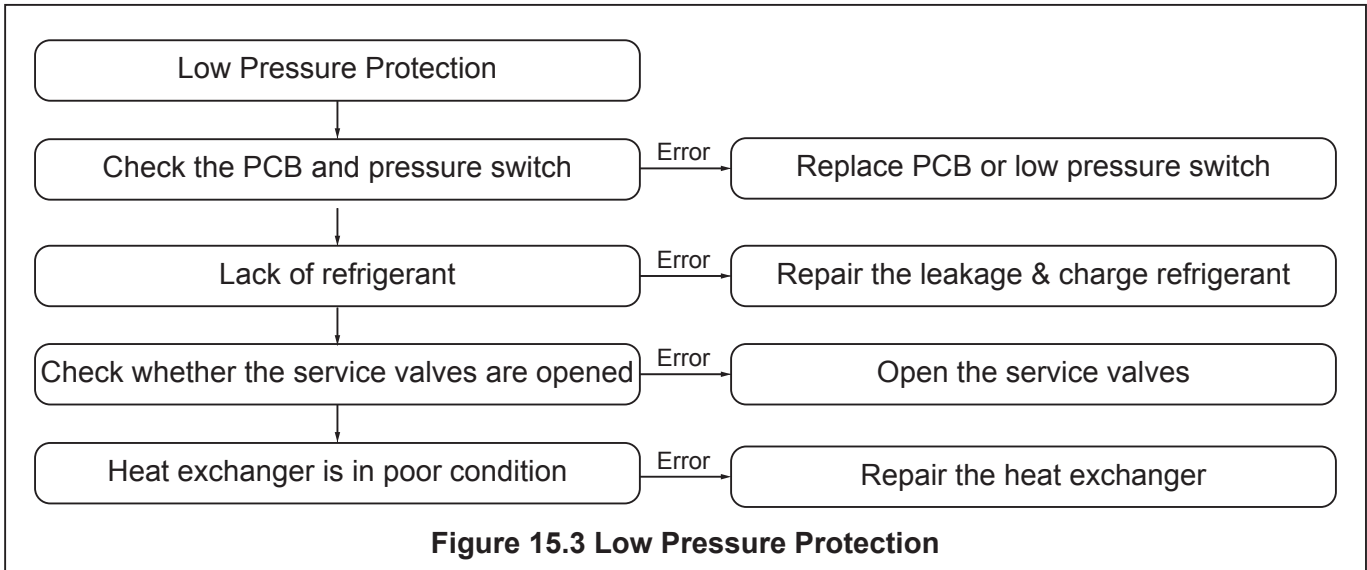

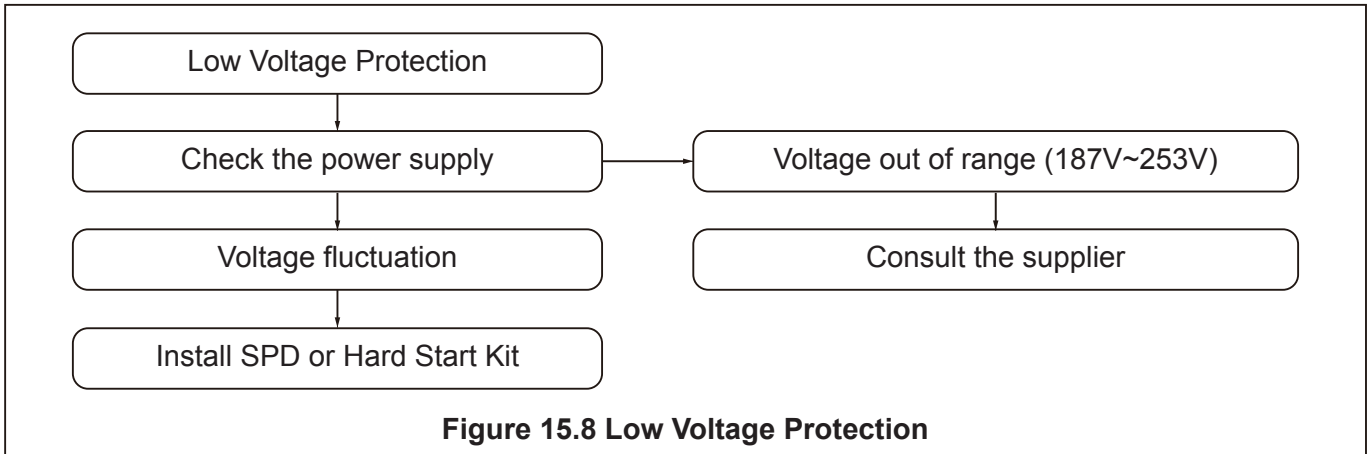
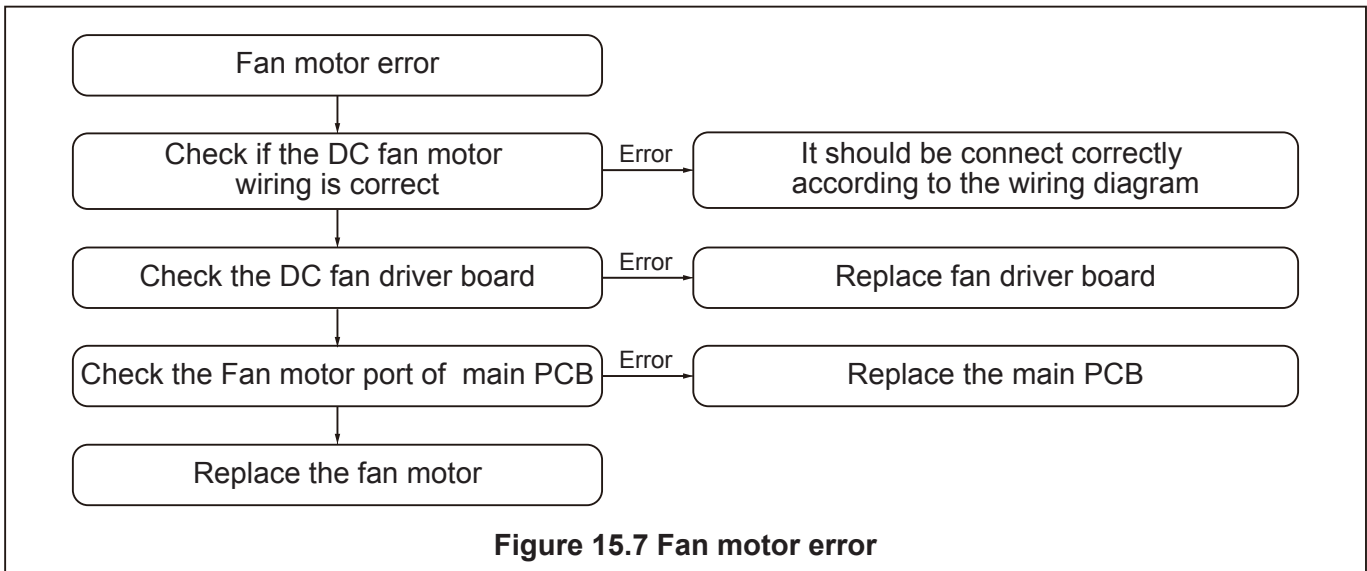
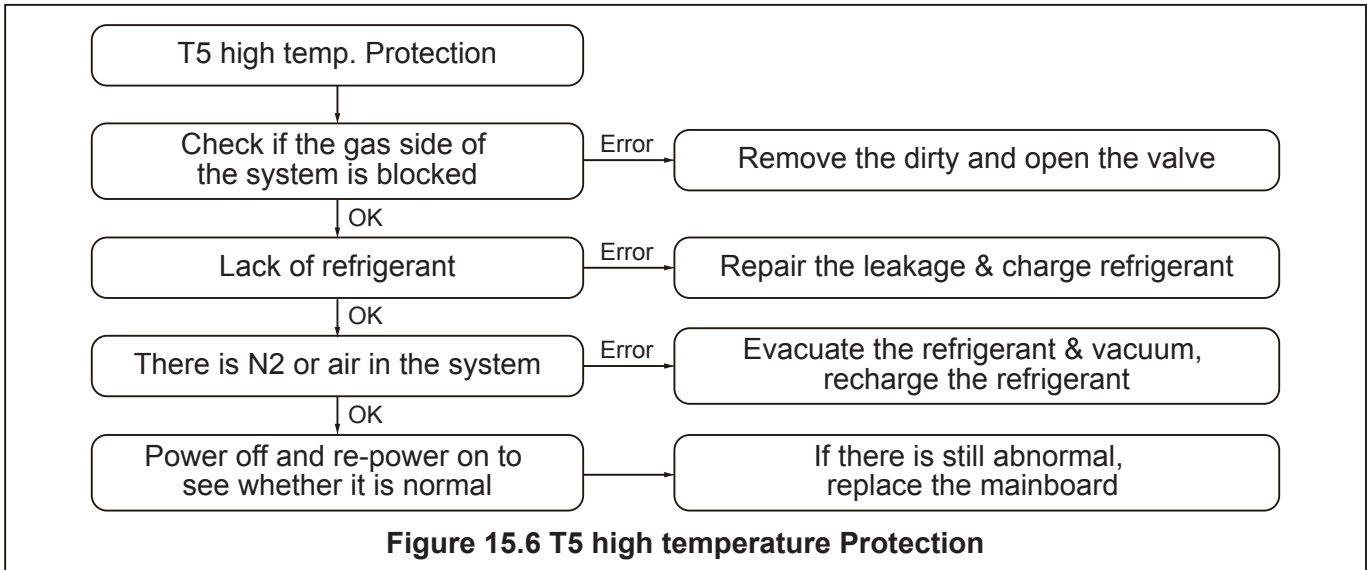

15.10 Temperature-Resistance Relationship Table (For Sensors)

Table 15.2 for T3, T4, TH

Temperature F	Temperature C	Electric resistance kΩ	Volt DC	Temperature F	Temperature C	Electric resistance kΩ	Volt DC
-5	-20.6	33.367	0.57	90	32.2	3.865	2.63
0	-17.8	29.227	0.64	95	35.0	3.508	2.75
5	-15.0	25.657	0.72	100	37.8	3.187	2.87
10	-12.2	22.595	0.80	105	40.6	2.900	2.99
15	-9.4	19.942	0.89	110	43.3	2.652	3.09
20	-6.7	17.697	0.98	115	46.1	2.421	3.20
25	-3.9	15.673	1.08	120	48.9	2.214	3.30
30	-1.1	13.917	1.18	125	51.7	2.025	3.40
40	4.4	11.060	1.40	130	54.4	1.861	3.49
45	7.2	9.867	1.52	135	57.2	1.706	3.58
50	10.0	8.823	1.64	140	60.0	1.567	3.66
55	12.8	7.884	1.76	145	62.8	1.442	3.74
60	15.6	7.101	1.89	150	65.6	1.327	3.82
65	18.3	6.409	2.01	155	68.3	1.226	3.89
70	21.1	5.767	2.14	160	71.1	1.132	3.96
75	23.9	5.150	2.28	165	73.9	1.046	4.02
80	26.7	4.700	2.39	170	76.7	0.967	4.08
85	29.4	4.266	2.51				

15.11 Temperature-Resistance Relationship Table (for T5 sensor)

Table 15.3 for T5

Temperature F	Temperature C	Electric resistance kΩ	Volt DC	Temperature F	Temperature C	Electric resistance kΩ	Volt DC
-5	-20.6	496.38	0.08	140	60.0	12.348	1.97
0	-17.8	422.97	0.09	145	62.8	11.164	2.10
5	-15.0	361.35	0.11	150	65.6	10.106	2.22
10	-12.2	309.74	0.13	155	68.3	9.193	2.34
15	-9.4	266.152	0.15	160	71.1	8.344	2.46
20	-6.7	230.462	0.17	165	73.9	7.585	2.58
25	-3.9	198.968	0.19	170	76.7	6.904	2.69
30	-1.1	172.231	0.22	175	79.4	6.313	2.80
35	1.7	149.467	0.26	180	82.2	5.761	2.92
40	4.4	130.642	0.29	185	85.0	5.263	3.02
45	7.2	113.87	0.33	190	87.8	4.815	3.13
50	10.0	99.456	0.37	195	90.6	4.410	3.23
55	12.8	87.095	0.42	200	93.3	4.057	3.33
60	15.6	76.425	0.48	205	96.1	3.724	3.42
65	18.3	67.501	0.53	210	98.9	3.423	3.51
70	21.1	59.457	0.60	215	101.7	3.149	3.60
75	23.9	52.489	0.67	220	104.4	2.910	3.67
80	26.7	46.429	0.74	225	107.2	2.689	3.75
85	29.4	41.322	0.82	230	110	2.476	3.82
90	32.2	36.682	0.90	235	112.8	2.288	3.89
95	35.0	32.619	0.99	240	115.6	2.117	3.96
100	37.8	29.068	1.09	245	118.3	1.965	4.02
105	40.6	25.948	1.19	250	121.1	1.821	4.08
110	43.3	23.291	1.29	255	123.9	1.690	4.13
115	46.1	20.855	1.39	260	126.7	1.569	4.19
120	48.9	18.708	1.51	265	129.4	1.462	4.23
125	51.7	16.809	1.62	270	132.2	1.360	4.28
130	54.4	15.184	1.73	275	135.0	1.266	4.32
135	57.2	13.682	1.85	280	137.8	1.180	4.36

16. Wiring Diagram

802035000271

Wiring Diagram

Factory settings		
Switch ON Position: Color upper half to show switch position is UP	<input checked="" type="checkbox"/> ON	Switch OFF Position: Color upper half to show switch position is DOWN
	<input type="checkbox"/> OFF	
MODEL	SW1	SW2
/	<input checked="" type="checkbox"/> 1 <input checked="" type="checkbox"/> 2 <input checked="" type="checkbox"/> 3 <input checked="" type="checkbox"/> 4	<input checked="" type="checkbox"/> 1 <input checked="" type="checkbox"/> 2 <input checked="" type="checkbox"/> 3 <input checked="" type="checkbox"/> 4
18K 24K 30K 36K	<input checked="" type="checkbox"/> 1 <input checked="" type="checkbox"/> 2 <input checked="" type="checkbox"/> 3 <input checked="" type="checkbox"/> 4	<input checked="" type="checkbox"/> 1 <input checked="" type="checkbox"/> 2 <input checked="" type="checkbox"/> 3 <input checked="" type="checkbox"/> 4
/	<input checked="" type="checkbox"/> 1 <input checked="" type="checkbox"/> 2 <input checked="" type="checkbox"/> 3 <input checked="" type="checkbox"/> 4	<input checked="" type="checkbox"/> 1 <input checked="" type="checkbox"/> 2 <input checked="" type="checkbox"/> 3 <input checked="" type="checkbox"/> 4
/	<input checked="" type="checkbox"/> 1 <input checked="" type="checkbox"/> 2 <input checked="" type="checkbox"/> 3 <input checked="" type="checkbox"/> 4	<input checked="" type="checkbox"/> 1 <input checked="" type="checkbox"/> 2 <input checked="" type="checkbox"/> 3 <input checked="" type="checkbox"/> 4
SW1/SW2 SELECTOR SWITCH (ON: <input checked="" type="checkbox"/> OFF: <input type="checkbox"/>)		
SW1-1	SW1-2	FAN SPEED TAPS
<input type="checkbox"/> OFF	<input checked="" type="checkbox"/> ON	LOW
<input type="checkbox"/> OFF	<input type="checkbox"/> OFF	MEDIUM
<input checked="" type="checkbox"/> ON	<input type="checkbox"/> OFF	MEDIUM HIGH
<input checked="" type="checkbox"/> ON	<input checked="" type="checkbox"/> ON	HIGH
SW1-3	<input checked="" type="checkbox"/> ON	Reserved
	<input type="checkbox"/> OFF	Reserved
SW1-4	<input checked="" type="checkbox"/> ON	Reserved
	<input type="checkbox"/> OFF	Reserved
SW2-1	<input checked="" type="checkbox"/> ON	Manual defrost
	<input type="checkbox"/> OFF	Reserved
SW2-2	<input checked="" type="checkbox"/> ON	Fix timed defrost
	<input type="checkbox"/> OFF	Automatic defrost
SW2-3	<input checked="" type="checkbox"/> ON	Timer 30min
	<input type="checkbox"/> OFF	Timer 60min
SW2-4	<input checked="" type="checkbox"/> ON	Reserved
	<input type="checkbox"/> OFF	Reserved

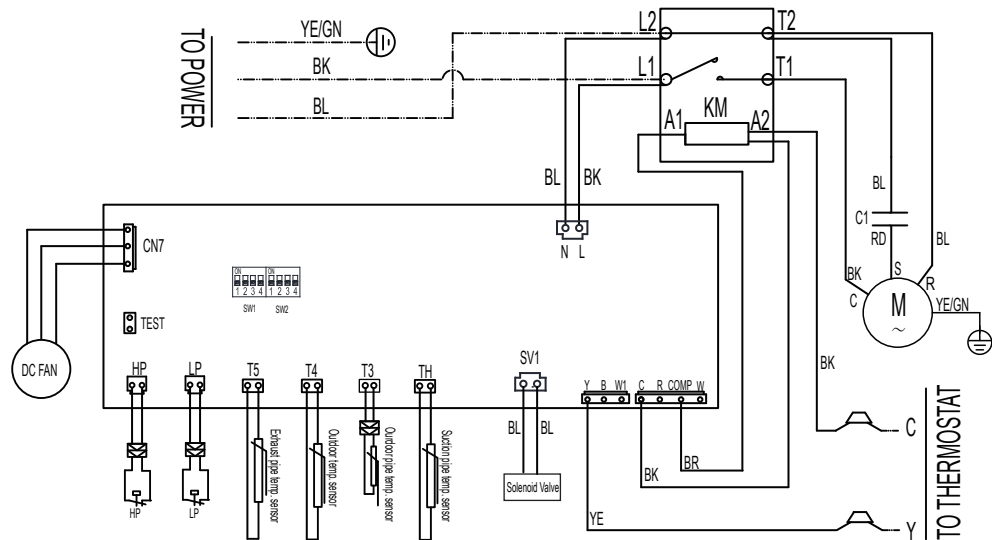

WIRE INFORMATION	WIRE COLOR CODE	NOTES	COMPONENT CODE
————— FACTORY CONNECTION	BL BLUE BK BLACK PR PURPLE GN GREEN	1. The units should use the unattached power switch, stated-cross-section wires and matching-spec. breaker. 2. Use the fuse within the specified scope, it can not be replaced by iron wires or brass wires. 3. The units should install the stated-cross-section earth wire and keep it grounding unflangly. 4. For indoor transformer, the current of 24V load voltage is not less than 1.5A.	KM CONTACTOR C1 CAPACITOR M COMPRESSOR TB TERMINAL BLOCK LP LOW PRESSURE SWITCH HP HIGH PRESSURE SWITCH 4-WAY 4-WAY VALVE COIL HEATER CRANKSHAFT HEATING BAND
- - - - - FIELD CONNECTION	RD RED WH WHITE BR BROWN OR ORANGE		
- · - · - FIELD CONNECTION(Optional)	GY GREY HE HENNA YE YELLOW		

Figure 16.1 Fixed speed AC

17. Cleaning and Maintenance

17.1 Cleaning Precautions



Warning:

- Any maintenance and cleaning of outdoor units can only be carried out by qualified maintenance personnel.
- Any unit maintenance can only be carried out by qualified maintenance personnel.



Caution: Electric shock

- Be sure to turn off the unit and disconnect the power supply before cleaning or maintenance.



Note:

- Do not use chemicals or chemically treated cloth to clean the unit.
- Do not use benzene, paint thinner, polishing powder or other solvents to clean this unit.



Be careful:

- When removing the filter, do not touch the metal parts in the unit. Sharp metal edges can cut you.

17.2 Pre-Season Inspection and Maintenance

At the start of each heating or cooling season, do the following:





	Turn off the unit and disconnect the power supply.
 	Check for damaged wires, check for leaks.
	Make sure that all air inlets and outlets are not blocked.

Table 17.1

17.3 Sheet Metal Parts Fastening



Note:

- Do not use a torque greater than 1.1lb*ft(1.5N*m) to drive the screws, otherwise the screws may slip and the sheet metal may not be completely tightened.



Technical Support

Single & Multi-Zone Mini Splits • PTACs • Portables •
TTWs • Light Commercial A/C Systems

Limited Warranty provided by Cooper&Hunter (hereby referred to as C&H) covers specified products and parts, subject to the following details:

Our warranty:

C&H Limited Warranty applies only to products installed by a licensed HVAC technician.

Product Registration: Products must be registered for Limited Warranty within 60 days of installation by licensed HVAC technician. Products can be registered at www.cooperandhunter.us/warranty. Alternatively, the warranty registration card from the product User's Manual can be filled out and sent in as instructed.

Warranty Coverage: Cooper&Hunter distributor warrants this product against failure due to defect in materials or workmanship under normal use and maintenance as follows. All warranty periods begin on the date of original installation. Damage resulting from failure to use, install or maintain the product in a manner consistent with manufacturer's recommendations shall render the warranty void. Cooper&Hunter, at its discretion, may request a report from a qualified technician prior to honoring a warranty claim. If a part fails due to defect during the applicable warranty period, Cooper&Hunter will provide a new or remanufactured part, at C&H's discretion, to replace the failed defective part at no charge. This Limited Warranty is subject to all provisions, conditions, limitations and exclusions listed below.

- Warranty is provided only to the first original owner of the Product, where it is originally installed, and is not transferable to the subsequent owners
- Limited Warranty applies only to systems properly installed by a state certified or licensed HVAC contractor, under applicable local and state law, in accordance with all applicable building codes and permits, C&H installation and operation instructions and good trade practices
- Warranty applies only to products remaining in their original installation location
- Defective parts must be returned to the distributor through a registered servicing dealer for credit

This warranty gives you specific legal rights. Rights may vary from state to state or province to province. For complete warranty details and duration of your specific product, please visit our website at cooperandhunter.us/warranty and follow the registration instructions.

LIMITATIONS OF WARRANTIES:

ALL IMPLIED WARRANTIES AND/OR CONDITIONS (INCLUDING IMPLIED WARRANTIES OR CONDITIONS OF MERCHANTABILITY AND FITNESS FOR A PARTICULAR USE OR PURPOSE) ARE LIMITED TO THE DURATION OF THIS LIMITED WARRANTY. SOME STATES OR PROVINCES DO NOT ALLOW LIMITATIONS ON HOW LONG AN IMPLIED WARRANTY OR CONDITION LASTS, SO THE ABOVE MAY NOT APPLY TO YOU. THE EXPRESSED WARRANTIES MADE IN THIS WARRANTY ARE EXCLUSIVE AND MAY NOT BE ALTERED, EXTENDED, OR CHANGED BY ANY DISTRIBUTOR, DEALER, OR OTHER PERSON, WHATSOEVER.

Warranty Exclusions: Cooper&Hunter is not responsible for any warranty claim:

1. For equipment installed outside of North America.
2. For equipment not installed according to manufacturer's guidelines.
3. For equipment which has been removed from the original place of installation and reinstalled at another place.
4. If registration information cannot be verified (i.e., invalid license number or wrong information provided).
5. For damages or repairs arising as a result of a faulty installation, inappropriate application, or improper use.
6. For damages or repairs arising from any external perils, out of Cooper&Hunter's control, such as fires, storms, accidents, floods, broken or frozen water pipes, electrical surges, input power with under or overvoltage, lightning, or existence of corrosive substances nearby.
7. For damages or repairs arising from use of non-compatible parts, third-party components, alterations, modifications, or improper applications.

8. For improper service or poor maintenance of the equipment, such as cleaning of all air filters, heat exchangers, fans, and blowers, in addition to any necessary lubrication of internal components and maintenance of external accessories.
9. For changes that can be considered cosmetic, including but not limited to small fin damages, scratches on the unit cover, etc.
10. For resetting of power or the circuit breakers and replacement of other types of fuses, both internal and external.
11. For any damage caused by the use of dirty, recycled, or wrong type of refrigerants and lubricants.
12. For damage due to moisture, air, dust, sand, dirt, etc., that have been allowed into the system.
13. For damage caused by continuing use of the product after a malfunction has been noticed or indicated at the display module, through an error code.
14. For damages or performance issues due to improper matching, product selection, undersizing, oversizing, improper installation, or misuse.
15. For loss or replacement of refrigerant, lubricant, or oil.
16. For labor or any costs associated with labor.

Warranty Begin Date: Warranty begins on the date of registration.

Warranty End Date: Products that have not been registered as instructed above are not covered under Warranty. The Warranty duration will vary from product to product and may have additional extensions granted through promotional benefits. Any part, component or product that is replaced under the terms of this Warranty, will be covered under the same Warranty for the duration in which the original Warranty was applicable. Please visit our website at cooperandhunter.us/warranty and follow the registration instructions to find specific details on your product warranty.

Warranty Procedure: The product owner or technician should contact **Cooper&Hunter Technical Support at (888) 293-9252, Monday to Friday from 9AM to 5PM EST** while the technician is on site servicing the unit. The product may display error codes. The technician should be on site while troubleshooting with the C&H Technical Support Agent so he or she can address symptoms observed, specific electrical and mechanical measurements, and other detailed information that may be required for proper diagnosis.

While technicians may refer to Cooper&Hunter's website or YouTube channel for helpful information, such as manuals and videos based on certain error codes, the technician will need to troubleshoot with the C&H Technical Support Agent for Warranty purposes. Cooper&Hunter is not able to remotely diagnose a product and or offer remedies, without proper diagnosis results.

When contacting Technical Support, the following forms and information need to be provided:

1. Unit's Model & Serial number
2. Date of Unit Installation by a Licensed Technician
3. Installer's EPA License Number
4. Place Unit was purchased

Cooper&Hunter may ask for photos and/or other diagnostic information it deems necessary prior to processing the Warranty claim.

It should be noted that C&H Technical Support Agents troubleshoot on a case-by-case basis, following best practices and procedures to diagnose problems and solutions. Through this process, it is most efficient to diagnose one issue or error code at a time. It is possible that the first suggested solution may or may not solve one problem of multiple failures, in which case the Technician will continue through troubleshooting for remaining issues/error codes.

Cooper&Hunter will furnish a new or refurbished part without any charge for the part itself, for the replacement of any part that has been determined, by Cooper&Hunter, to have failed, at its sole discretion, due to defects in its materials or workmanship under standard use and proper maintenance. The payment of the shipping costs for the part will be the sole responsibility of the owner of the product. Cooper& Hunter reserves the right to ask the owner of the product to return the failed part before or after a replacement part is sent out.

Labor cost, materials and other costs: Any labor costs and/or the costs for the supplies or materials used or purchased in the field for the replacement of the defective part, remain the responsibility of the owner. No other costs involved in diagnosis, lodging, transportation, servicing, repair, replacement, installation, removal, shipping, etc., are to be covered under the Warranty.

Refrigerant: Any costs related to charging, recharging, adjustment, or removal of refrigerant, and the cost of the refrigerant itself, are not covered under any circumstances. All products go through vigorous quality controls at various stations and leave the factory in perfect working and sealed condition. Products are individually tested in highly sensitive helium vacuum chambers for existence of refrigerant leaks. Cooper&Hunter does not cover any claims related to the lack of refrigerant in new products, discovered upon arrival, or during installation, as well as subsequent refrigerant loss occurring at any time afterward.

This Warranty is not transferable. No person or entity is authorized to change the terms and conditions outlined in this Warranty agreement, in any respect, nor to create any additional obligations or liabilities for any party involved.

This warranty agreement supersedes all prior warranty agreements between the parties and constitutes the complete, final and exclusive understanding of the parties with respect to the subject matter. All prior negotiations, representations, or promises, whether oral or written, of either party shall be deemed to have been merged herein.

If any part of this warranty agreement shall be invalidated for any reason, such part shall be deleted, and the remainder shall be unaffected and shall continue in full force and effect. This Warranty provides you certain legal rights and you may also have other rights, which vary from State to State. Therefore, some of these limitations or exclusions may not apply to you.

States with Express and Implied Warranties: Products in states with Express and Implied Warranties do not need to be registered for C&H Warranty. However, for Warranty support, installation invoice should be provided.

Pursuing legal remedies:

ARBITRATION CLAUSE. IMPORTANT. PLEASE REVIEW THIS ARBITRATION CLAUSE, AS IT AFFECTS YOUR LEGAL RIGHTS.

1. This arbitration clause affects your rights against Cooper&Hunter and any of its employees, agents, affiliates, successors, or assignees, all of whom together are referred to below as “we” or “us” for the simplicity of reference.
2. **ARBITRATION REQUIREMENT: EXCEPT AS STATED BELOW, ANY DISPUTE BETWEEN YOU AND ANY OF US SHALL BE DECIDED BY NEUTRAL AND BINDING ARBITRATION, RATHER THAN ANY COURT OR BY TRIAL BY JURY. ARBITRATION WILL BE HANDLED ONLY ON AN INDIVIDUAL BASIS AND ALL PARTIES EXPRESSLY WAIVE; ANY RIGHTS TO PARTICIPATE AS A CLASS REPRESENTATIVE OR CLASS MEMBER, ANY RIGHTS TO CLASS ARBITRATION OR ANY CONSOLIDATION OF INDIVIDUAL ARBITRATIONS. THE ARBITRATOR WILL BE A MEMBER OF THE AMERICAN ARBITRATION ORGANIZATION.** The meaning of “Dispute” has the broadest possible meaning allowable by law, including any controversy, claim or other dispute, relating to or arising from the purchase of the product, any of the warranties upon the product, or the condition of the product, as well as the determination of the application or the scope of the Arbitration Clause itself. Rights to appeal and discovery are also limited in arbitration based on the rules of the arbitration organizations.
3. **Governing Law:** Effect and procedures of arbitration will be governed by the Federal Arbitration Act (9 U.S.C. § et seq.) rather than any related state law. In case of any substantive warranty, your claims and rights under such substantive warranty will be governed by the applicable law of the state in which Product was purchased.
4. **Location of the Arbitration:** Unless otherwise provided under the applicable law, arbitration hearing will be conducted in the judicial district in Miami-Dade County, Florida.
5. **Costs of the Arbitration:** Unless otherwise provided under the applicable law, each party will be responsible for; its own costs payable to the arbitration organization, and the costs of their attorneys, experts or other fees.
6. **Survival and Enforceability of the Arbitration Clause:** This arbitration clause will survive the expiration or termination of this warranty agreement, indefinitely.

