



Wall-Mounted Air Handler  
Cooling Only

SPLIT SYSTEM

WALL MOUNTED UNIT

# Installation Manual

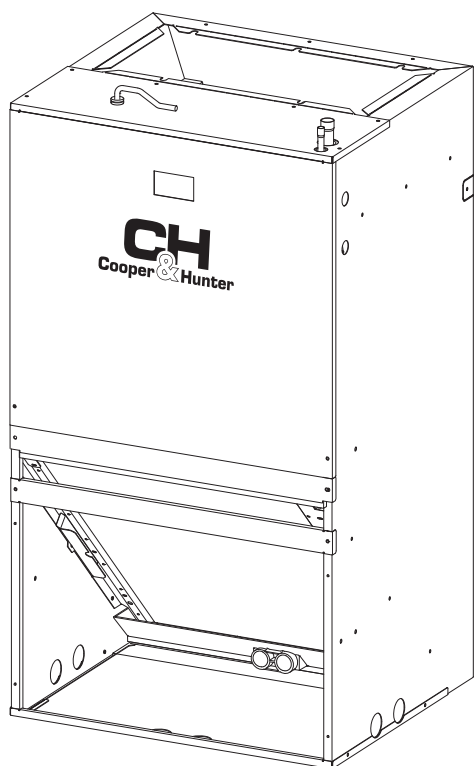

**Models:**

CH-UC18AHUWM  
CH-UC24AHUWM  
CH-UC30AHUWM  
CH-UC36AHUWM

**IMPORTANT NOTE:**



Read this manual carefully before installing or operating your new air conditioning unit. Make sure to save this manual for future reference.







# About the Company

With more than 25 years of experience in air conditioning and ventilation, **Cooper&Hunter** is considered one of the HVAC leaders in the US market. Distributed in more than 55 countries worldwide, the brand is dedicated to technological innovation and consumer-driven product development, while generating HVAC equipment that adheres to the highest quality standards in the US. Our focus is to provide reliable, energy-efficient, and cost-effective residential and commercial air conditioning solutions.

# Learn more about your unit

Learn more technical information about your unit at [www.cooperandhunter.us](http://www.cooperandhunter.us), where you can find submittals, leaflets, videos and all technical specifications of your unit.

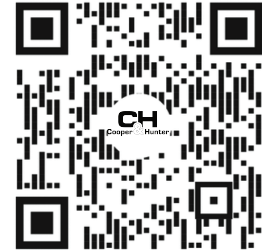
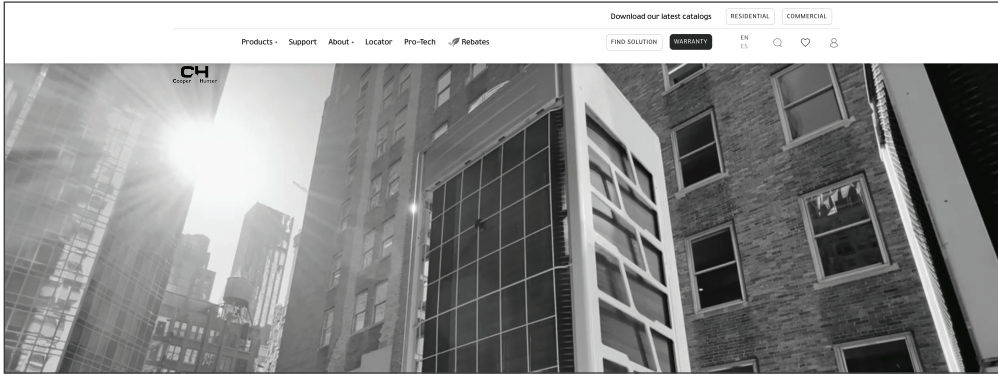

## Step 1

On the website [cooperandhunter.us](http://cooperandhunter.us), type in your unit model number into the search field and click enter.

## Step 2

Make sure the unit that appears in your search results matches your unit and click on it for more details.

## Step 3

On the detail page of your unit you will be able to view the technical specifications, description and additional documents, such as Submittals, Leaflets and Videos about your unit.

# Warranty registration

It is important to register your unit's warranty. This will provide more security and agility whenever you need to request technical support from **Cooper&Hunter**.

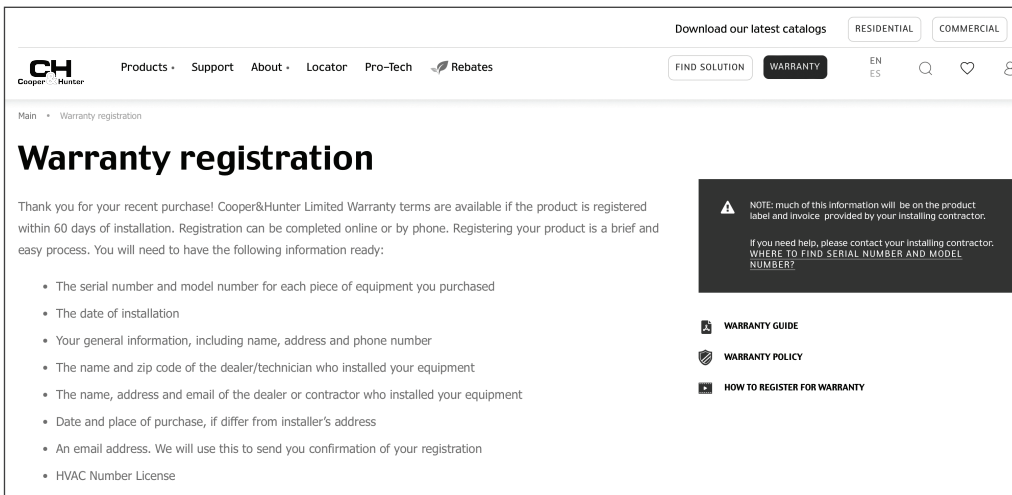

## Step 1

Visit the warranty registration page at [cooperandhunter.us/warranty](http://cooperandhunter.us/warranty) and follow the steps to register a new unit. For more information on the warranty terms and policies, see pages at the end of your user manual.

## Step 2

Complete the entire warranty registration form, including the information of the licensed technician who installed your equipment. Once complete, you will receive a confirmation email stating your application to register your unit has been submitted.

# How to apply for the rebate program

Almost all Cooper&Hunter equipment is eligible for the rebate program. Visit our website to see if the rebates apply to your location.

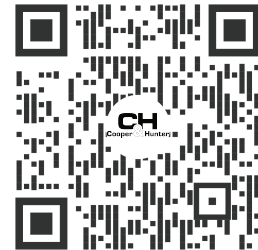
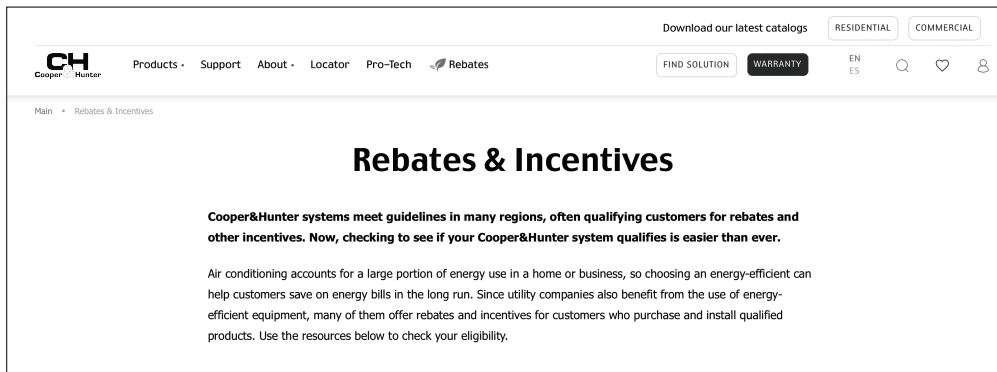

## Step 1

Go to [cooperandhunter.us/rebates](https://cooperandhunter.us/rebates) to add your zip code and select your outdoor unit to see if your unit qualifies for the rebate.

## Step 2

See the list of available rebates and instructions on how to apply for each available rebate.

## Our Commitment to Innovation and Efficiency

At Cooper&Hunter, innovation is at the heart of everything we do. We continuously invest in research and development to bring you the most advanced, reliable, and energy-efficient HVAC solutions. Our goal is to lead the industry in environmental and energy efficiency, and we will spare no effort to achieve this.

We are proud to offer products that, not only meet, but exceed the highest quality standards. Our dedication to technological innovation ensures that you receive the best possible performance and value from your HVAC systems.

## Explore more

For more information, including tutorials and updates, visit our official YouTube channel, Instagram and Facebook page. Simply search our social media to access a variety of helpful videos and guides.



 YouTube

@CooperandHunterusa



 Instagram

@cooperandhunterusa

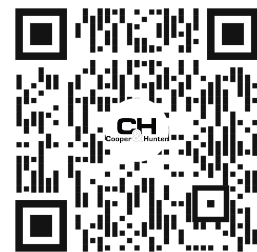

 Facebook

Cooper&Hunter USA

Remember to **subscribe** to stay up-to-date with the latest content!

# CONTENTS

1. Symbol and Key to Safety Instructions.....	01
2. Accessories .....	09
3. Installation Instructions.....	10
4. Electrical Wiring.....	17
5. Airflow Performance .....	20
6. Ductwork .....	22
7. Refrigerant Pipe Connection .....	23
8. Air Filter (Not Factory Installed).....	26
9. Filter.....	27
10. Maintenance.....	28
11. Wiring Diagram .....	29

# 1. Symbol and Key to Safety Instructions





## 1.1 Symbol Keywords



### WARNING

The warnings in this document are identified by warning triangles printed on a black background. The keyword at the beginning of the warning indicates the type and severity of the risk if no measures are taken to prevent it.

The following keywords are defined and used in this document:

	<b>Dangerous</b>	Means a hazardous situation, which, if not avoided, will lead to death or serious injury.
	<b>Warning</b>	Indicates a hazardous situation, which may lead to death or serious injury if not avoided.
	<b>Caution</b>	Indicates a hazardous situation, which may cause mild to moderate injury if not avoided.
	<b>Note</b>	Used to deal with behaviors unrelated to personal injury.

### Important Information



This symbol represents important information that is not harmful to people or property.

## 1.2 Safety

Please Read Before Continuing.

### Warning:

- The unit must be installed by qualified personnel with a capability certificated for handling R32 refrigerant. Refer to regulation and laws in use on installation location.
- This appliance is not intended for use by persons (including children) with reduced physical, sensory or mental capabilities, or lack of experience and knowledge, unless they have been given supervision or instruction concerning use of the appliance by a person responsible for their safety.
- The appliance shall be installed in accordance with national wiring regulations.
- Children should be supervised to ensure that they do not play with the appliance.
- The minimum clearance to combustible surfaces (curtains, blinds, etc.) from the appliance should be 11.81in (300 mm).
- Maximum outlet air temperature with electric heater should be limited to 90°C(194°F).
- Leak detection system installed. Unit must be powered except for service
- Before accessing the connection terminals, all power circuits must be disconnected.
- Please read these instructions carefully before attempting to install or operate. Failure to follow these instructions may result in incorrect installation, adjustment, repair or maintenance, which may result in fire, electric shock, property damage, personal injury or death.
- Installation, service, maintenance and repair of this unit must be performed by a certified technician.
- Servicing shall be performed only as recommended by the manufacturer.
- Product uninstallation and recycling must be performed by a certified technician.
- keep any required ventilation openings clear of obstruction;
- The appliance shall be stored in a well-ventilated area where the room size corresponds to the room area as specified for operation
- The appliance shall be stored in a room without continuously operating open flames (for example an operating gas appliance) and ignition sources (for example an operating electric heater)



### QUALIFICATION OF WORKERS

The installation and servicing of this equipment must be performed by qualified, experienced technicians only. Professional installation personnel should have the following experience:

- Installing the electric heater
- Opening of sealed components
- Opening of ventilated enclosures
- Commissioning and troubleshooting
- Checking the electric control part and wiring
- Breaking into the refrigerant circuit and charging



This document is property of customer and should be kept together with this equipment.

These instructions do not cover all the different variations of the system, nor do they provide all the unexpected situations that may be encountered during the installation process.



The manufacturer recommends installing only approved matched indoor and outdoor systems. Some of the benefits of installing approved matched indoor and outdoor split systems are maximum efficiency, optimum performance and the best overall system reliability.

**Warning: Fire, electric shock, property damage, personal injury or death**



- The whole installation process must comply with NATIONAL, STATE AND LOCAL CODES. If you need more information, please contact your local dealer.
- Dispose of properly in accordance with federal or local regulations. Flammable refrigerant used.
- Risk of fire due to flammable refrigerant used. Follow handling instructions carefully in compliance with national regulations

**Warning: Risk of electric shock**



- Can cause injury or death. Disconnect all remote electric power supplies before servicing. More than one disconnect switch may be required to cut off the power of the equipment. Dangerous voltage can cause serious personal injury or death.

**Warning: Electric shock**



- If the fan assembly needs to be dismantled, all disconnect switches supplying power to the equipment must be powered off and locked (if the device cannot be seen), so that the field power cord can be safely dismantled from the fan assembly. Otherwise, it may cause electric shock, personal injury or death.

**Warning: Fire, electric shock, property damage, personal injury or death**







- Flammable refrigerant used. Consult repair manual/owner' s guide before attempting to service this product. All safety precautions must be followed.
- Due to possible equipment damage or personal injury, installation, repair and maintenance should be carried out by trained qualified maintenance personnel. Consumers are advised to only clean/replace the filter screen. Do not operate the equipment with the access panel removed.

**Warning:**



- Do not use means to accelerate the defrosting process or to clean, other than those recommended by the manufacturer.
- The appliance shall be stored in a room without continuously operating ignition sources (for example: open flames, an operating gas appliance or an operating electric heater).
- Do not pierce or burn.
- Be aware that refrigerants may not contain an odour.

	<b>WARNING</b>	This symbol that this appliance used a flammable refrigerant. If the refrigerant is leaked and exposed to an external ignition source, there is a risk of fire.
	<b>CAUTION</b>	This symbol that the operation manual should be read carefully.
	<b>CAUTION</b>	This symbol that a service personnel should be handling this equipment with reference to the installation manual.
	<b>CAUTION</b>	This symbol that information is available such as the operating manual or installation manual.

 **Warning:**

- This product may expose you to chemicals including lead and lead components, which are known to cause cancer, birth defects or other reproductive harm in California. For more information, please visit [www.P65Warnings.ca.gov](http://www.P65Warnings.ca.gov).

 **Warning: Electric shock**

- The device must be permanently grounded. Otherwise, it will cause electric shock, personal injury or death.

 **Note: Fire risk**

- The product is only used for one or two residences.
- The materials of pressure ventilation system and piping system must meet the latest NFPA 90B standard.

 **Note:**

- Make sure the fan bracket is fastened (3 motor mounting bolts-Figure1). Then, before operating the device, check whether the wheels are firmly fixed on the motor shaft.

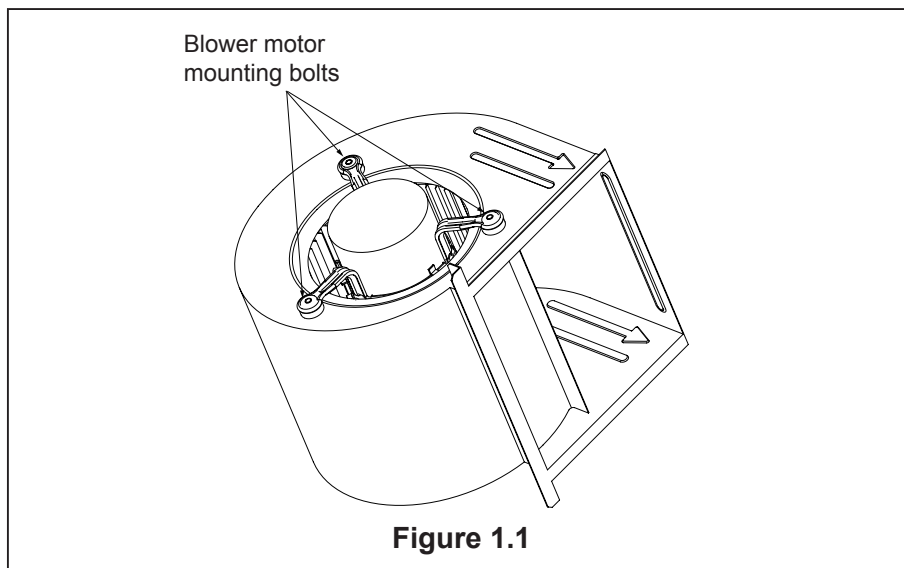

## 1.3 Safety Precautions for R32 Refrigerant



### Warning:

- Do not use means to accelerate the defrosting process or to clean, other than those recommended by the manufacturer.
- The appliance shall be stored in a room without continuously operating ignition sources (for example: open flames, an operating gas appliance or an operating electric heater).
- Do not pierce or burn.
- Be aware that refrigerants may not contain an odour.

### Equipment leak detection

Field-made refrigerant joints indoors shall be tightness tested. The test method shall have a sensitivity of 5 grams per year of refrigerant or better under a pressure of at least 0,25 times the maximum allowable pressure. No leak shall be detected.

### Qualification of workers

Every working procedure like maintenance, service and repair operations that affects safety means shall only be carried out by competent persons.

Examples for such working procedures are:

- breaking into the refrigerating circuit;
- opening of sealed components;
- opening of ventilated enclosures.

### Checks to the area

Prior to beginning work on systems containing FLAMMABLE REFRIGERANTS, safety checks are necessary to ensure that the risk of ignition is minimised.

### Work procedure

Work shall be undertaken under a controlled procedure so as to minimise the risk of a flammable gas or vapour being present while the work is being performed.

### General work area

All maintenance staff and others working in the local area shall be instructed on the nature of work being carried out. Work in confined spaces shall be avoided.

### Checking for presence of refrigerant

The area shall be checked with an appropriate refrigerant detector prior to and during work, to ensure the technician is aware of potentially toxic or flammable atmospheres. Ensure that the leak detection equipment being used is suitable for use with all applicable refrigerants, i.e. non-sparking, adequately sealed or intrinsically safe.

### Presence of fire extinguisher

If any hot work is to be conducted on the refrigerating equipment or any associated parts, appropriate fire extinguishing equipment shall be available to hand. Have a dry powder or CO<sub>2</sub> fire extinguisher adjacent to the charging area.

### No ignition sources

No person carrying out work in relation to a REFRIGERATING SYSTEM which involves exposing any pipe work shall use any sources of ignition in such a manner that it may lead to the risk of fire or explosion. All possible ignition sources, including cigarette smoking, should be kept sufficiently far away from

the site of installation, repairing, removing and disposal, during which refrigerant can possibly be released to the surrounding space. Prior to work taking place, the area around the equipment is to be surveyed to make sure that there are no flammable hazards or ignition risks. "No Smoking" signs shall be displayed.

### **Ventilated area**

Ensure that the area is in the open or that it is adequately ventilated before breaking into the system or conducting any hot work. A degree of ventilation shall continue during the period that the work is carried out. The ventilation should safely disperse any released refrigerant and preferably expel it externally into the atmosphere.

### **Checks to the refrigerating equipment**

Where electrical components are being changed, they shall be fit for the purpose and to the correct specification. At all times the manufacturer's maintenance and service guidelines shall be followed. If in doubt, consult the manufacturer's technical department for assistance.

The following checks shall be applied to installations using FLAMMABLE REFRIGERANTS:

- the actual REFRIGERANT CHARGE is in accordance with the room size within which the refrigerant containing parts are installed;
- the ventilation machinery and outlets are operating adequately and are not obstructed;
- if an indirect refrigerating circuit is being used, the secondary circuit shall be checked for the presence of refrigerant
- marking to the equipment continues to be visible and legible. Markings and signs that are illegible shall be corrected;
- refrigerating pipe or components are installed in a position where they are unlikely to be exposed to any substance which may corrode refrigerant containing components, unless the components are constructed of materials which are inherently resistant to being corroded or are suitably protected against being so corroded.

### **Checks to electrical devices**

Repair and maintenance to electrical components shall include initial safety checks and component inspection procedures. If a fault exists that could compromise safety, then no electrical supply shall be connected to the circuit until it is satisfactorily dealt with. If the fault cannot be corrected immediately but it is necessary to continue operation, an adequate temporary solution shall be used. This shall be reported to the owner of the equipment so all parties are advised. Initial safety checks shall include:

- that capacitors are discharged: this shall be done in a safe manner to avoid possibility of sparking;
- that no live electrical components and wiring are exposed while charging, recovering or purging the system;
- that there is continuity of earth bonding.

### **Repairs to sealed components**

Sealed electrical components shall be replaced.

### **Repair to intrinsically safe components**

Intrinsically safe components must be replaced.

### **Cabling**

Check that cabling will not be subject to wear, corrosion, excessive pressure, vibration, sharp edges or any other adverse environmental effects. The check shall also take into account the effects of aging or continual vibration from sources such as compressors or fans.

### **Detection of flammable refrigerants**

Under no circumstances shall potential sources of ignition be used in the searching for or detection of refrigerant leaks. A halide torch (or any other detector using a naked flame) shall not be used.

The following leak detection methods are deemed acceptable for all refrigerant systems.

Electronic leak detectors may be used to detect refrigerant leaks but, in the case of FLAMMABLE REFRIGERANTS, the sensitivity may not be adequate, or may need re-calibration. (Detection equipment shall be calibrated in a refrigerant-free area.) Ensure that the detector is not a potential source of ignition and is suitable for the refrigerant used. Leak detection equipment shall be set at a percentage of the LFL of the refrigerant and shall be calibrated to the refrigerant employed, and the appropriate percentage of gas (25 % maximum) is confirmed.

Leak detection fluids are also suitable for use with most refrigerants but the use of detergents containing chlorine shall be avoided as the chlorine may react with the refrigerant and corrode the copper pipe-work.

If a leak is suspected, all naked flames shall be removed/extinguished.

If a leakage of refrigerant is found which requires brazing, all of the refrigerant shall be recovered from the system, or isolated (by means of shut off valves) in a part of the system remote from the leak. Removal of refrigerant shall be according to Removal and evacuation.

### **Removal and evacuation**

When breaking into the refrigerant circuit to make repairs – or for any other purpose –conventional procedures shall be used. However, for flammable refrigerants it is important that best practice be followed, since flammability is a consideration. The following procedure shall be adhered to:

- safely remove refrigerant following local and national regulations;
- evacuate;
- purge the circuit with inert gas (optional for A2L);
- evacuate (optional for A2L);
- continuously flush or purge with inert gas when using flame to open circuit; and
- open the circuit.

The refrigerant charge shall be recovered into the correct recovery cylinders if venting is not allowed by local and national codes. For appliances containing flammable refrigerants, the system shall be purged with oxygen-free nitrogen to render the appliance safe for flammable refrigerants. This process might need to be repeated several times. Compressed air or oxygen shall not be used for purging refrigerant systems.

For appliances containing flammable refrigerants, refrigerants purging shall be achieved by breaking the vacuum in the system with oxygen-free nitrogen and continuing to fill until the working pressure is achieved, then venting to atmosphere, and finally pulling down to a vacuum (optional for A2L). This process shall be repeated until no refrigerant is within the system (optional for A2L). When the final oxygen-free nitrogen charge is used, the system shall be vented down to atmospheric pressure to enable work to take place.

The outlet for the vacuum pump shall not be close to any potential ignition sources, and ventilation shall be available.

### **Charging procedures**

In addition to conventional charging procedures, the following requirements shall be followed.

- Ensure that contamination of different refrigerants does not occur when using charging equipment. Hoses or lines shall be as short as possible to minimise the amount of refrigerant contained in them.
- Cylinders shall be kept in an appropriate position according to the instructions.
- Ensure that the REFRIGERATING SYSTEM is earthed prior to charging the system with refrigerant
- Label the system when charging is complete (if not already).
- Extreme care shall be taken not to overfill the REFRIGERATING SYSTEM.

Prior to recharging the system, it shall be pressure-tested with the appropriate purging gas. The system shall be leak-tested on completion of charging but prior to commissioning. A follow up leak test shall be carried out prior to leaving the site.

## Decommissioning

Before carrying out this procedure, it is essential that the technician is completely familiar with the equipment and all its detail. It is recommended good practice that all refrigerants are recovered safely. Prior to the task being carried out, an oil and refrigerant sample shall be taken in case analysis is required prior to re-use of recovered refrigerant. It is essential that electrical power is available before the task is commenced.

- a) Become familiar with the equipment and its operation.
- b) Isolate system electrically.
- c) Before attempting the procedure, ensure that:
  - mechanical handling equipment is available, if required, for handling refrigerant cylinders;
  - all personal protective equipment is available and being used correctly;
  - the recovery process is supervised at all times by a competent person;
  - recovery equipment and cylinders conform to the appropriate standards.
- d) Pump down refrigerant system, if possible.
- e) If a vacuum is not possible, make a manifold so that refrigerant can be removed from various parts of the system.
- f) Make sure that cylinder is situated on the scales before recovery takes place.
- g) Start the recovery machine and operate in accordance with instructions.
- h) Do not overfill cylinders (no more than 80 % volume liquid charge).
- i) Do not exceed the maximum working pressure of the cylinder, even temporarily.
- j) When the cylinders have been filled correctly and the process completed, make sure that the cylinders and the equipment are removed from site promptly and all isolation valves on the equipment are closed off.
- k) Recovered refrigerant shall not be charged into another REFRIGERATING SYSTEM unless it has been cleaned and checked

## Labelling

Equipment shall be labelled stating that it has been de-commissioned and emptied of refrigerant. The label shall be dated and signed. For appliances containing FLAMMABLE REFRIGERANTS, ensure that there are labels on the equipment stating the equipment contains FLAMMABLE REFRIGERANT.

## Recovery

When removing refrigerant from a system, either for servicing or decommissioning, it is recommended good practice that all refrigerants are removed safely.



When transferring refrigerant into cylinders, ensure that only appropriate refrigerant recovery cylinders are employed. Ensure that the correct number of cylinders for holding the total system charge is available. All cylinders to be used are designated for the recovered refrigerant and labelled for that refrigerant (i.e. special cylinders for the recovery of refrigerant). Cylinders shall be complete with pressure-relief valve and associated shut-off valves in good working order. Empty recovery cylinders are evacuated and, if possible, cooled before recovery occurs.

The recovery equipment shall be in good working order with a set of instructions concerning the equipment that is at hand and shall be suitable for the recovery of the flammable refrigerant. If in doubt, the manufacturer should be consulted. In addition, a set of calibrated weighing scales shall be available and in good working order. Hoses shall be complete with leak-free disconnect couplings and in good condition.

The recovered refrigerant shall be processed according to local legislation in the correct recovery cylinder, and the relevant waste transfer note arranged. Do not mix refrigerants in recovery units and especially not in cylinders.

If compressors or compressor oils are to be removed, ensure that they have been evacuated to an acceptable level to make certain that flammable refrigerant does not remain within the lubricant. The compressor body shall not be heated by an open flame or other ignition sources to accelerate this process. When oil is drained from a system, it shall be carried out safely.

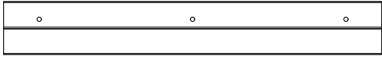
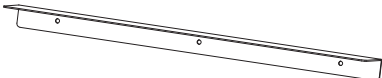
## 2. Accessories

Name	Quantity	Shape
INSTALLATION INSTRUCTIONS	1	
WALL MOUNT BRACKET	2	
WALL MOUNT BRACKET (ONLY FOR30K/36K)	1	
DRAIN PLUG	1	
RUBBER GASKET	1	

# 3. Installation Instructions

## 3.1 Unpacking

Carefully unpack the unit and inspect the contents for damage. If any damage is found at the time of delivery, proper notification and claims should be made with the carrier.

Check the rating plate to assure model number and voltage. Furthermore, check that kits match with what was ordered. The manufacturer should be notified within 5 days of any discrepancy or parts shortage.

## 3.2 Location

The small air handler should be centrally located and may be installed in a closet, alcove, utility room, or basement. Minimum clearances must be met. The air handler comes standard with two different options for mounting, wall mount or frame mount. Both mounting options require the unit to be level from side to side and from front to back in order to allow condensate to properly drain from the unit. Failure to do this will result in condensate leaking out from the unit, potentially causing structural damage to the surrounding support structures, dry wall, carpet, etc. Also, both mounting structures require the ability to accommodate a minimum of 150 lb load. Failure to do this will cause damage to the support structure and potentially damage the unit.

### 3.2.1 WALL MOUNT

The air handler comes standard with an upper and lower wall mount bracket. Reference Figure 3.1 for more detail.

1. Remove lower wall mounting bracket from the back of the unit by removing one screw which attaches the bracket to the air handler. Note: Discard the screw after you have removed the wall mounting bracket.
2. Install bracket on the wall by using 3 wood screws (not provided). Make sure the bracket is level in order to provide proper drainage from the unit. Note: Do not attach the wall mounting bracket into un-supported dry wall. Make sure that the wood screws are going into a structure that can support a minimum load of 150 lb.
3. Lift the air handler above the wall mounting bracket and attach the unit to the installed bracket. Reference Figure 3.1.
4. Install the additional bottom plate for extra support for this type mounting (see Figure 3.1).

*Note: The additional plate is shipped in the bottom of the shipping carton (only for 30/36k unit).*

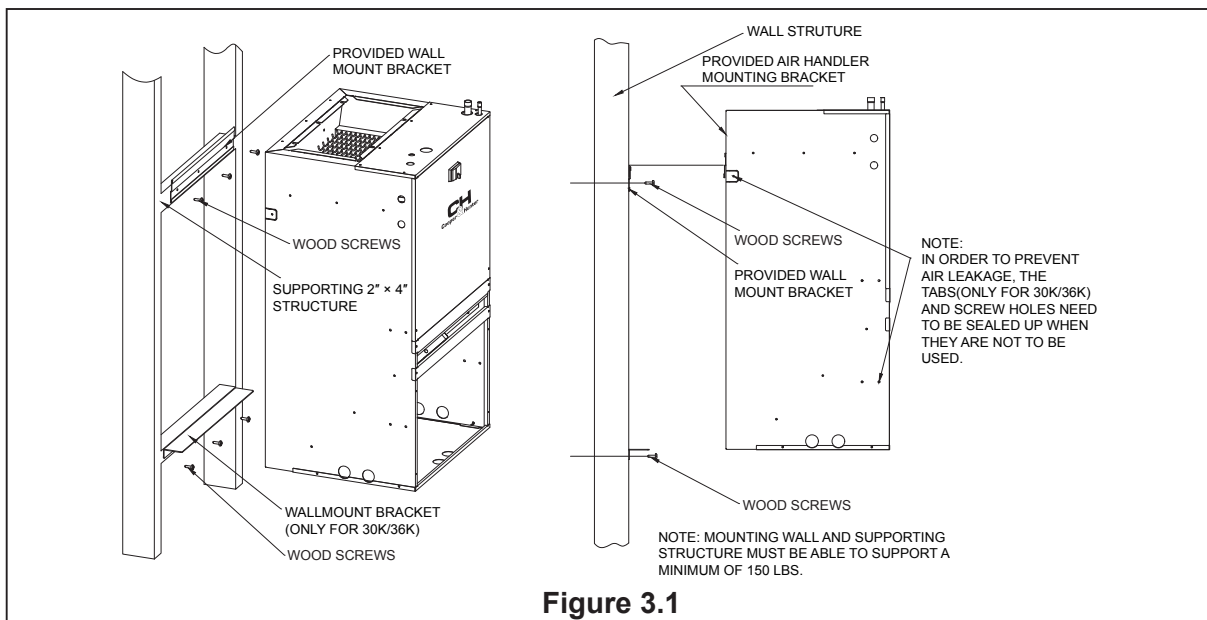
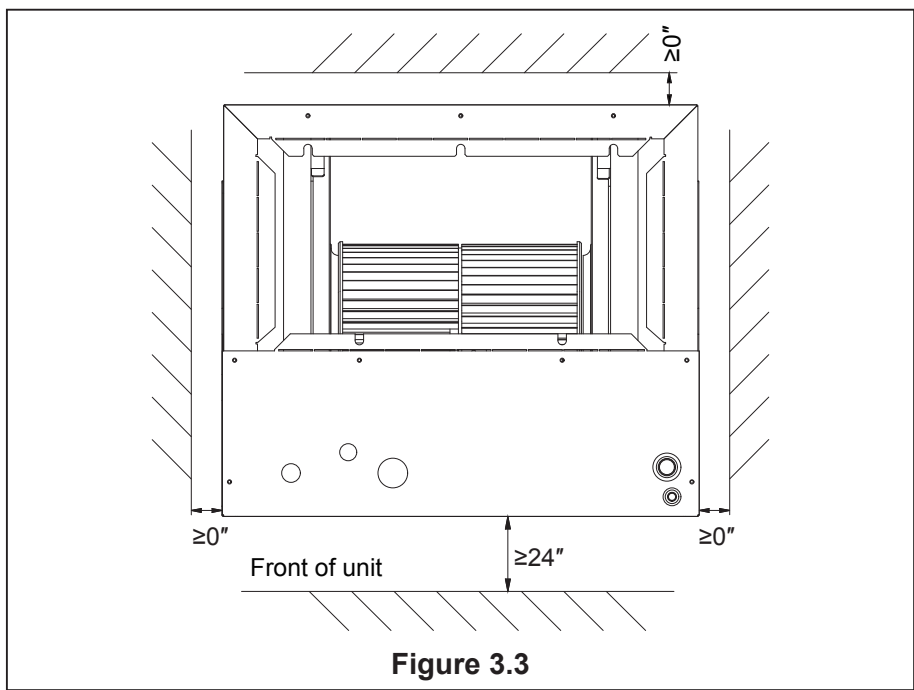
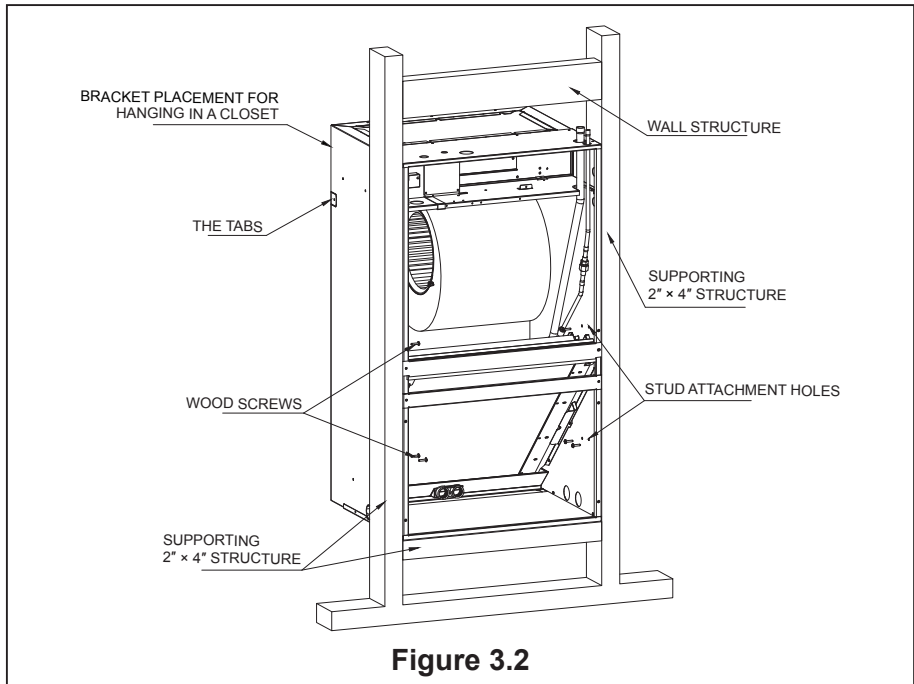

Figure 3.1

### 3.2.2 FRAME MOUNT

The air handler comes with 8 clearance holes (4 on each side). These holes are used to mount the air handler inside of a frame structure (see Figure 3.2). When mounting in this fashion, make sure that the wood screws are mounted from within the air handler and not outside of the unit. Install the screws from outside the unit, and avoid damaging the coil. If the frame does not provide support in the front of the unit and additional support is needed, open up the tabs and fix the unit to the frame or other support structure with screws (only for 30K/36K). Select a solid and level site to ensure proper installation of the frame mount. Verify that there is sufficient space for installation and maintenance. (See Figure 3.3 ) **IMPORTANT:** The (8) wood screws are not provided with the unit.

#12 x 1 1/2" wood screws are recommended. When the unit is installed on a wood frame, the screws should be used to fix the unit to the studs. If they are not used, the unit may fall down or cause other damage. (See Figure 3.2) for frame mount installation.





### Warning: Note

- As shown in Figure 3.3, the installed device must have the required clearance. Failure to follow these instructions may result in equipment damage and/or premature equipment failure.

### 3.2.3 CONFIGURATIONS

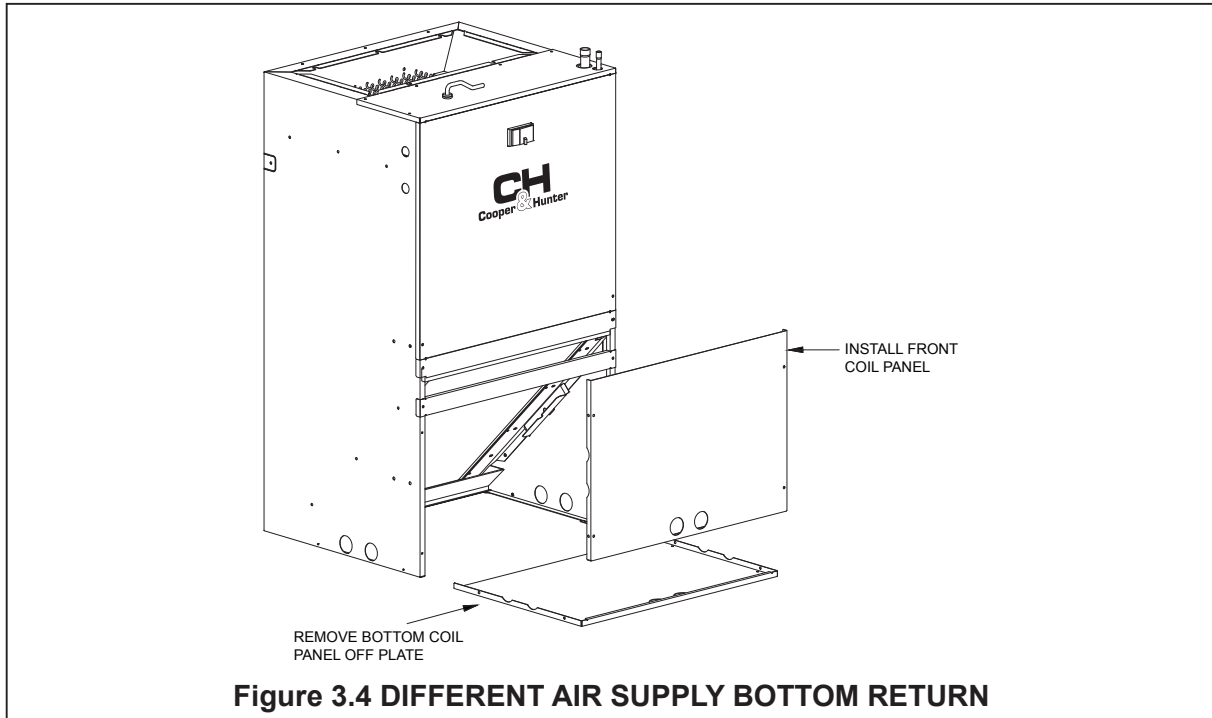

Conversion: Divert the return air from the factory standard front return to a bottom return. Remove the cross brace when converting cabinet to bottom return.

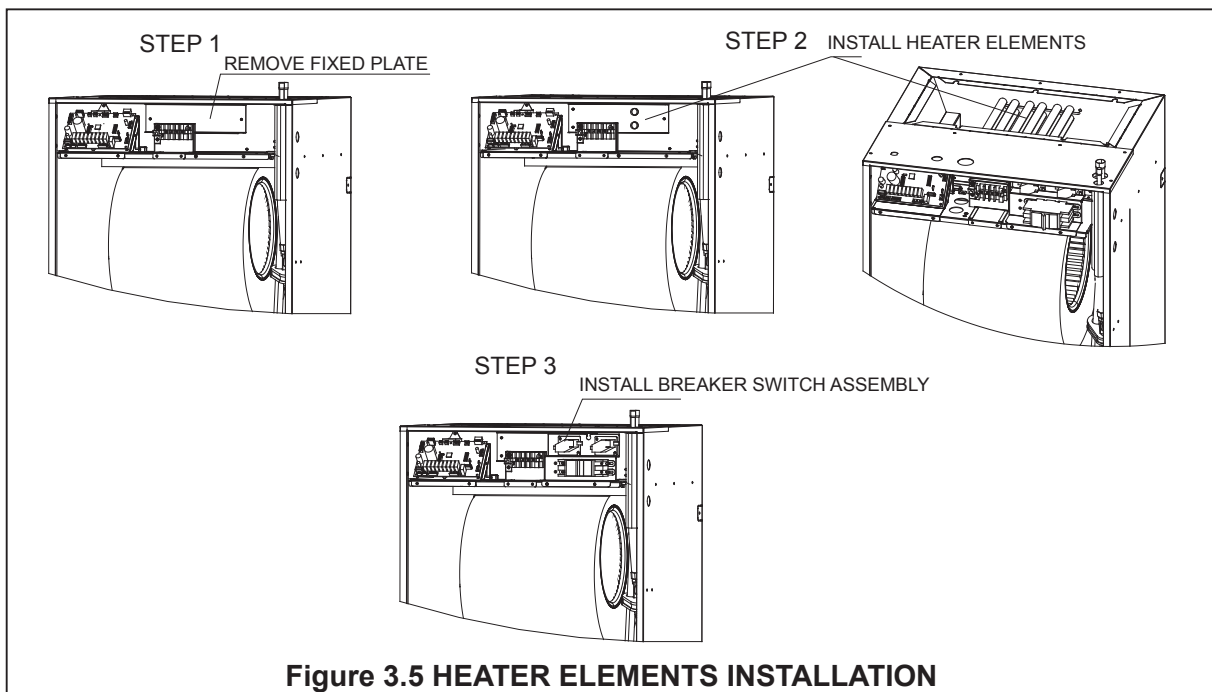

### 3.3 Installation in High Humidity Environment

When the unit is installed in a hot and humid place, if the temperature in the installation space exceeds 86 °F and the RH (relative humidity) exceeds 80%, it is recommended to insulate the outside of the cabinet. Use glass wool or polyethylene foam as insulation material; The thickness should be greater than 2 inches, and it must be suitable for the installation space opening. Condensate may also be produced on the insulation surface. Ensure that insulation materials designed for HVAC systems are used.

### 3.4 Unit Dimension

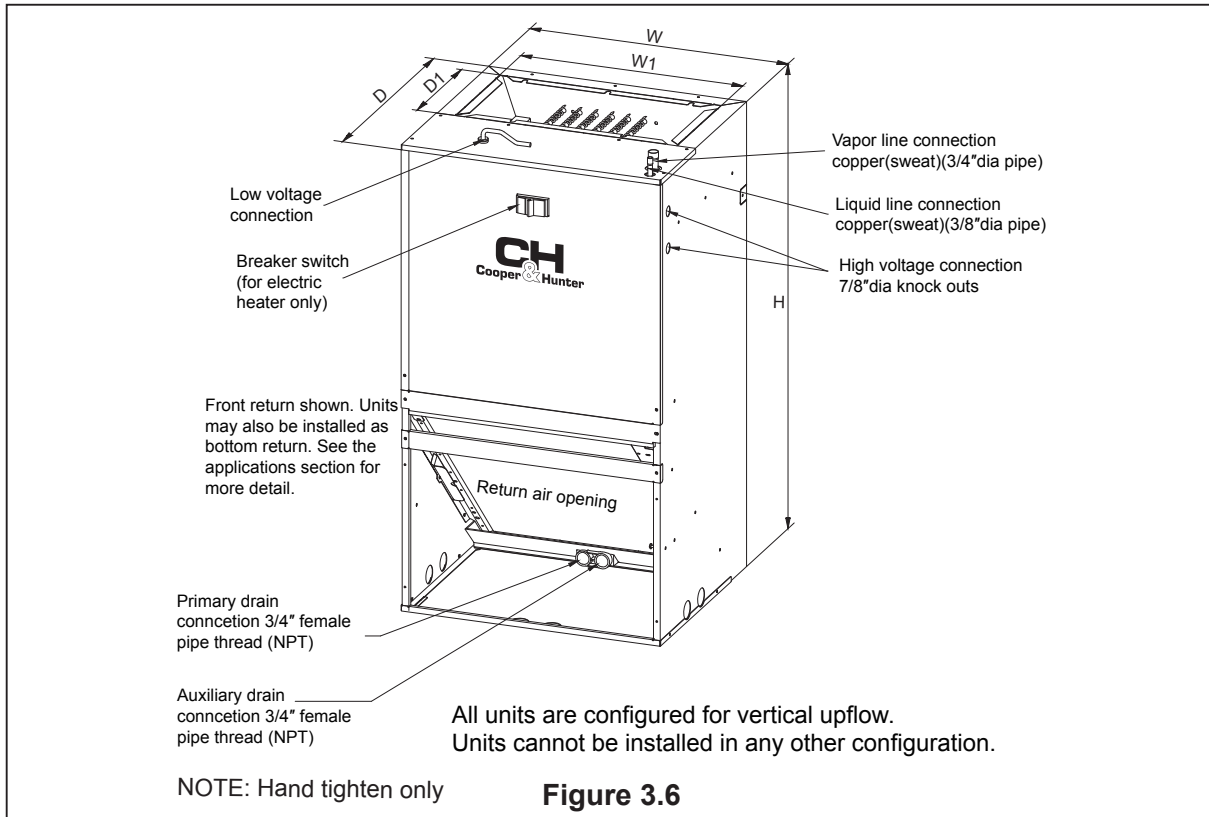

**Table 3.1 Unit Dimension**

Model Size	Dimensions inch (mm)					Unit Weight /Shipping Weight (LBS.(kg))
	Unit Height "H" inch (mm)	Unit Width "W" inch (mm)	Unit Width "W1" inch (mm)	Unit Length "D" inch (mm)	Unit Length "D1" inch (mm)	
18	36-1/2 (928)	20-2/3 (526)	17-1/2 (446)	15 (381)	9-1/2 (242)	81.4/91.3 (37)/(41.5)
24	36-1/2 (928)	20-2/3 (526)	17-1/2 (446)	15 (381)	9-1/2 (242)	81.4/91.3 (37)/(41.5)
30	39-1/2 (1004)	22 (559)	18-4/5 (478)	19 (483)	9-1/2 (242)	104.5/116.6 (47.5)/(53)
36	39-1/2 (1004)	22 (559)	18-4/5 (478)	19 (483)	9-1/2 (242)	104.5/116.6 (47.5)/(53)

### 3.5 Steps to Replacing the Leak Detection Sensor

GENERAL SPECIFICATIONS of LEAK DETECTION SENSOR:

MINIMUM LIFETIME: 15 YEARS

It needs to be replaced with the same model. If in doubt, please consult the manufacturer for assistance.

1. Remove the screws and the front panel, and disconnect the plug of leak detection sensor wire from the circuit board (Figure 3.5, Step 1).
2. Remove the screws and pull out the leak detection sensor with the wire (Figure 3.5, Step 2).
3. Replace the new leak detection sensor and fix it back to its original position, plug and tie the wires to the electronic control board in the same way as before. Install the access panels, make sure there is no outstanding gap to allow refrigerant escape in case of leakage.

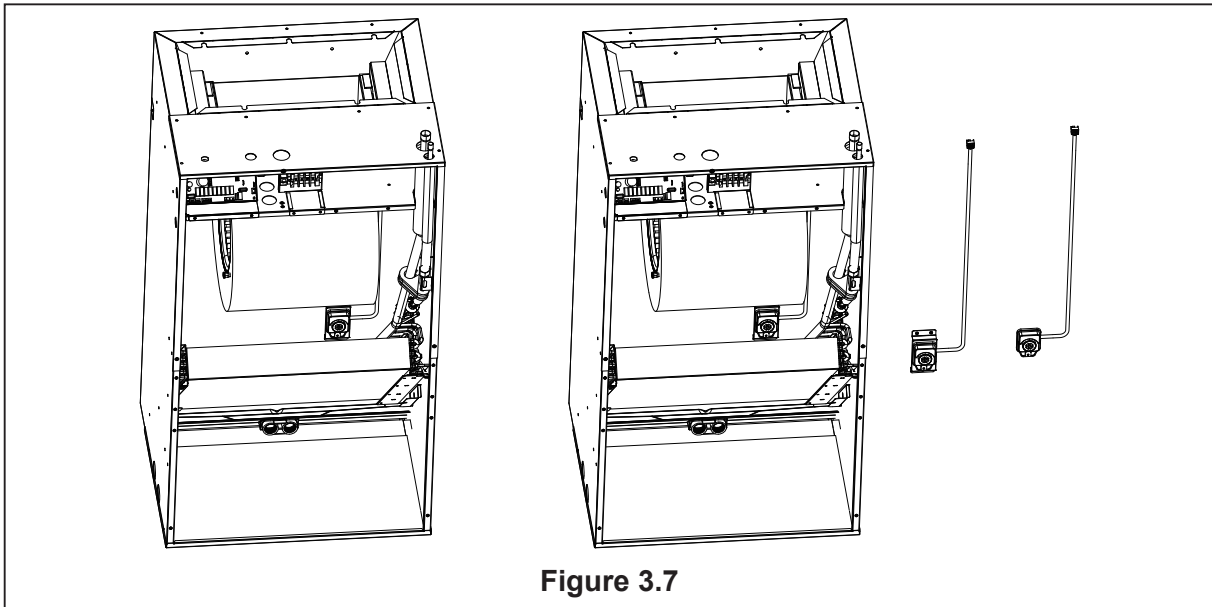
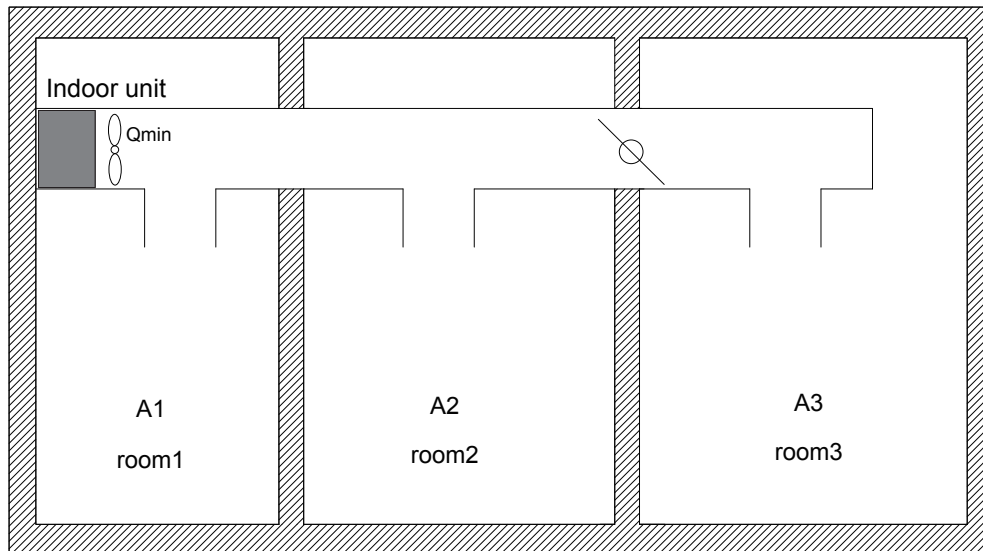

Figure 3.7

### 3.6 Installation Room Size Rules

The installation mode needs to be performed in the following way. Minimum room height, 2.2 m (7.22 ft) (if applicable). Minimum room area (operating or storage), 20.76 m<sup>2</sup> and 223.33 ft<sup>2</sup>. Note: For minimum room areas at higher installation heights, see instructions (note is optional). Installation method.



Make sure that the applied room space area TA is larger than the TA min.

**Table 3.2**

18K AC			18K HP		
Piping length (ft)/(m)	Refrigerant perfusion (oz)/(kg)	TA min (ft <sup>2</sup> )/(m <sup>2</sup> )	Piping length (ft)/(m)	Refrigerant perfusion (oz)/(kg)	TA min (ft <sup>2</sup> )/(m <sup>2</sup> )
25/(7.62)	70.55/(2.00)	66.08/6.14	25/(7.62)	82.89/(2.35)	77.65/7.22
50/(15.24)	84.05/(2.38)	78.67/7.31	50/(15.24)	96.39/(2.73)	90.24/8.39
75/(22.86)	97.55/(2.76)	91.26/8.48	75/(22.86)	109.89/(3.11)	102.83/9.56
100/(30.48)	111.05/(3.14)	103.85/9.65	100/(30.48)	123.39/(3.49)	115.41/10.73
131/(39.93)	127.79/(3.62)	119.46/11.10	131/(39.93)	140.13/(3.97)	131.03/12.18
24K AC			24K HP		
Piping length (ft)/(m)	Refrigerant perfusion (oz)/(kg)	TA min (ft <sup>2</sup> )/(m <sup>2</sup> )	Piping length (ft)/(m)	Refrigerant perfusion (oz)/(kg)	TA min (ft <sup>2</sup> )/(m <sup>2</sup> )
25/(7.62)	77.60/(2.2)	72.69/6.76	25/(7.62)	82.89/(2.35)	77.65/7.22
50/(15.24)	91.10/(2.58)	85.28/7.93	50/(15.24)	96.39/(2.73)	90.24/8.39
75/(22.86)	104.60/(2.96)	97.87/9.10	75/(22.86)	109.89/(3.11)	102.83/9.56
100/(30.48)	118.10/(3.34)	110.46/10.27	100/(30.48)	123.39/(3.49)	115.41/10.73
131/(39.93)	134.84/(3.82)	126.07/11.72	131/(39.93)	140.13/(3.97)	131.03/12.18
30K AC			30K HP		
Piping length (ft)/(m)	Refrigerant perfusion (oz)/(kg)	TA min (ft <sup>2</sup> )/(m <sup>2</sup> )	Piping length (ft)/(m)	Refrigerant perfusion (oz)/(kg)	TA min (ft <sup>2</sup> )/(m <sup>2</sup> )
25/(7.62)	116.40/(3.3)	109.04/10.14	25/(7.62)	116.40/(3.3)	109.04/10.14
50/(15.24)	129.90/(3.68)	121.63/11.31	50/(15.24)	129.90/(3.68)	121.63/11.31
75/(22.86)	143.40/(4.06)	134.22/12.48	75/(22.86)	143.40/(4.06)	134.22/12.48
100/(30.48)	156.90/(4.44)	146.80/13.65	100/(30.48)	156.90/(4.44)	146.80/13.65
131/(39.93)	173.64/(4.92)	162.42/15.10	131/(39.93)	173.64/(4.92)	162.42/15.10
36K AC			36K HP		
Piping length (ft)/(m)	Refrigerant perfusion (oz)/(kg)	TA min (ft <sup>2</sup> )/(m <sup>2</sup> )	Piping length (ft)/(m)	Refrigerant perfusion (oz)/(kg)	TA min (ft <sup>2</sup> )/(m <sup>2</sup> )
25/(7.62)	123.46/(3.5)	115.65/10.75	25/(7.62)	125.22/(3.55)	117.30/10.90
50/(15.24)	136.96/(3.88)	128.24/11.92	50/(15.24)	138.72/(3.93)	129.89/12.07
75/(22.86)	150.46/(4.26)	140.82/13.09	75/(22.86)	152.22/(4.31)	142.48/13.24
100/(30.48)	163.96/(4.64)	153.41/14.26	100/(30.48)	165.72/(4.69)	155.07/14.41
131/(39.93)	180.70/(5.12)	169.03/15.71	131/(39.93)	182.46/(5.17)	170.68/15.86
<p>Note: TA=A1+A2+A3+...+An (If there is a damper in the duct. When damper is open, the room area TA is the sum of all room area connected by ductwork. If it is closed, TA is the sum of the room areas before the damper.)</p>					

Table: Minimum room area/zone de chambre minimale (e.g.: 36K AC Installation connection piping length of 25 feet and refrigerant charge of 123.46oz results in an installation room area of not less than 115.65 sq. ft.)

**Table 3.3**

Model	Qmin [m <sup>3</sup> /h(SCFM)]	Qmin <sub>A</sub> [m <sup>3</sup> /h(SCFM)]
18K AC	578 (340)	367 (216)
18K HP	578 (340)	402 (236)
24K AC	578 (340)	387 (228)
24K HP	578 (340)	402(236)
30K AC/HP	891 (524)	499 (294)
36K AC	891 (524)	519 (305)
36K HP	891 (524)	524 (308)

Note: Qmin refers to the Minimum airflow of the indoor unit (see Table 5.1 for details), which is not less than Qmin<sub>A</sub>.

## 4. Electrical Wiring

The wiring on site must comply with the National Electric Code (C.E.C. in Canada) and any applicable local regulations.



### Warning: Electric shock

- Before installation or maintenance, please disconnect all power supply of the device. More than one disconnect switch may be required to cut off the power of the equipment. Dangerous voltage can cause serious personal injury or death.

### 4.1 Power Supply Wiring

It is important to have a suitable power supply connected to the device being installed. For more detailed requirements, please refer to the device rating label, wiring diagram and electrical data in the installation instructions.

- If necessary, install a branch circuit breaker of sufficient size, which is located within sight and easy to install.



When installing an electric heater, the device may be equipped with one or two 30-60 amp circuit breakers. These circuit breakers protect internal lines and act as disconnecting devices when short circuit occurs. The circuit breaker installed in the device does not provide overcurrent protection for the power connection, so its size may be larger than that of the branch circuit protection.

- The power supply line of the circuit must be a minimum 221°F copper conductor. For current carrying capacity, wire size and circuit protector requirements, please refer to electrical data in this section. The power supply protection device can be a fuse or a "HACR" type circuit breaker.
- High-voltage wires can pass through the tapping holes on the right, left or top of the device.
- 7/8", 1-3/8" diameter tapped holes can be used to connect high-voltage wires to the device.
- The high-voltage wires must be connected to the red and black wires in the control part of the air handler.

### 4.2 Control Wiring



The low-voltage control line should not run in the conduit together with the high-voltage line. Keep the distance between the two catheters according to local codes.

- Scenes less than 100 feet in length should use 18 AWG colored low-voltage wires. 16 AWG wire should be used for scenes with a length of more than 100 feet.
- See Figure 2.7 for the connection position of low-voltage wires.
- For the correct wiring instructions, please refer to the wiring diagram located back side of the air handler blower access panel.
- After installation, make sure that the low-voltage and high-voltage wiring are kept separate.

### 4.3 Grounding



### Danger: Electric shock

- The device must be permanently grounded. Otherwise, it will cause electric shock, personal injury or death.

- When installed according to existing electrical codes, grounding can be through wires or metal conductors.
- Grounding can also be achieved by connecting the grounding wire to the ground lug (ground lug) on the machine.
- When multiple power supply circuits are used, each circuit needs to be grounded plate separately.
- The grounding plate is located at the upper right of the cabinet.

## 4.4 Electrical Data

**Table 4.1 Electrical Data**

Model	Voltage	Hertz	HP	Fan speed	Circuit AMPS	MCA(A)	MOP(A)
18K	208/230	60	1/3	5	1.1	4	6
24K	208/230	60	1/3	5	1.1	4	6
30K	208/230	60	1/2	5	2.0	5	6
36K	208/230	60	1/2	5	2.0	5	6

## 4.5 MCA/MOP Data of Electric Heat Kit

**Table 4.2 Applicable Heat Kits for AHU Multi Position Installation**

AHU model	electric heat(kW) 208/230VAC	Current (A) 208/230VAC	MCA (A) 208/230VAC	MAX.Fuse or Breaker (HACR) Ampacity		Fan speed				
				208 VAC	230 VAC	1	2	3	4	5
18K	3.8/4.6	18.27/19.96	25/30	40	45	●	●	●	●	●
	5.6/6.9	27.08/29.95	30/35	50	57	x	x	●	●	●
24K	3.8/4.6	18.27/19.96	25/30	40	45	●	●	●	●	●
	5.6/6.9	27.08/29.95	30/35	50	57	x	x	●	●	●
	7.5/9.2	36.11/39.93	40/45	55	60	x	x	x	●	●
30K	3.8/4.6	18.27/19.96	25/30	40	45	●	●	●	●	●
	5.6/6.9	27.08/29.95	30/35	50	57	x	●	●	●	●
	7.5/9.2	36.11/39.93	40/45	55	60	x	x	●	●	●
36K	3.8/4.6	18.27/19.96	25/30	40	45	●	●	●	●	●
	5.6/6.9	27.08/29.95	30/35	50	57	x	●	●	●	●
	7.5/9.2	36.11/39.93	40/45	55	60	x	x	●	●	●

- Heat kit applicable for AHU 4-way position installation.
- Ampacities for MCA and Fuse/breaker including the blower motor.
- The heat pump system needs specific airflow. Each ton of cooling requires 350 to 450 cubic feet (CFM) of air per minute, or nominally 400 CFM.

**Table 4.3 Heater Kit Accessories**

Description	18	24	30	36
5 kW heating kit, single-pole circuit breaker	•	•	•	•
7.5 kW heating kit, single-pole circuit breaker	•	•	•	•
10 kW heating kit, single/double pole circuit breaker	×	•	•	•

• indicates availability, and × indicates unavailability

**Warning:**



- This product is used with A2L type refrigerant, the electric heater must meet the requirements of the UL 60335-2-40 standard for A2L type refrigerant.
- The electric heating must be installed by qualified personnel. Refer to current regulations and laws for installation location.
- This appliance is not intended for use by persons (including children) with reduced physical, sensory or mental capabilities, or lack of experience and knowledge, unless they have been given supervision or instruction concerning use of the appliance by a person responsible for their safety. Children should be supervised to ensure that they do not play with the appliance.
- The appliance shall be installed in accordance with national wiring regulations.

# 5. Airflow Performance

The air flow data is based on the cooling performance of coil and without filter. Performance table, select the appropriate product.

External static pressure ESP should be kept within the minimum and maximum limits shown in the following table to ensure the normal operation of cooling, heating and electric heating.

**Table 5.1 Air Flow Performance**

Model size of air processor	Motor speed		SCFM							
			External Static Pressure-Inch Water Column [kPa]							
			0[0]	0.1[.02]	0.2[.05]	0.3[.07]	0.4[.10]	0.5[.12]	0.6[.15]	
18K	Tap (5)	SCFM	917	898	853	821	789	761	730	
		Watts	179	182	189	195	200	205	210	
	Tap (4)	SCFM	872	837	804	770	737	709	679	
		Watts	156	161	165	171	176	181	186	
	Tap (3)	SCFM	814	776	739	705	671	639	606	
		Watts	128	133	138	143	147	151	156	
	Tap (2)	SCFM	708	664	622	580	542	496	432	
		Watts	93	97	102	105	110	114	121	
	Tap (1)	SCFM	633	585	538	494	438	382	340	
		Watts	69	73	77	81	85	91	98	
	24K	Tap (5)	SCFM	917	898	853	821	789	761	730
			Watts	179	182	189	195	200	205	210
Tap (4)		SCFM	872	837	804	770	737	709	679	
		Watts	156	161	165	171	176	181	186	
Tap (3)		SCFM	814	776	739	705	671	639	606	
		Watts	128	133	138	143	147	151	156	
Tap (2)		SCFM	708	664	622	580	542	496	432	
		Watts	93	97	102	105	110	114	121	
Tap (1)		SCFM	633	585	538	494	438	382	340	
		Watts	69	73	77	81	85	91	98	
30K		Tap (5)	SCFM	1318	1282	1241	1205	1165	1113	1071
			Watts	268	276	282	289	296	304	311
	Tap (4)	SCFM	1230	1192	1151	1110	1055	1013	971	
		Watts	223	230	236	243	250	257	263	
	Tap (3)	SCFM	1129	1071	1025	976	933	886	840	
		Watts	172	178	184	191	197	203	209	
	Tap (2)	SCFM	1039	976	926	876	826	779	718	
		Watts	136	142	147	153	159	165	172	
	Tap (1)	SCFM	894	836	781	725	668	595	524	
		Watts	98	103	108	112	118	124	129	
	36K	Tap (5)	SCFM	1318	1282	1241	1205	1165	1113	1071
			Watts	268	276	282	289	296	304	311
Tap (4)		SCFM	1230	1192	1151	1110	1055	1013	971	
		Watts	223	230	236	243	250	257	263	
Tap (3)		SCFM	1129	1071	1025	976	933	886	840	
		Watts	172	178	184	191	197	203	209	
Tap (2)		SCFM	1039	976	926	876	826	779	718	
		Watts	136	142	147	153	159	165	172	
Tap (1)		SCFM	894	836	781	725	668	595	524	
		Watts	98	103	108	112	118	124	129	

 The highlighted area indicates the airflow within the required range.

Note:

1. The advanced airflow must be used as the rated airflow for the full-load operation of the machine.
2. The rated airflow of a system without an electric heater kit requires more than 300 cubic feet of air per minute (CFM).
3. The rated airflow of a system with an electric heater kit requires more than 300 cubic feet of air per minute (CFM).
4. The air distribution system has the greatest influence on air flow. Therefore, the contractor should only use the procedures recognized by the industry.
5. The design and construction of air duct should be done carefully. Poor design or process will lead to a significant decline in system performance.
6. The air supply duct should be set along the periphery of the air-conditioned space with appropriate size. Improper location or insufficient airflow may lead to insufficient ventilation or noise in the ductwork.
7. The installer should balance the air distribution system to ensure that all rooms in the room have proper quiet airflow. The speedometer or airflow hood can be used to balance and verify the branch duct and system airflow (CFM).

## **5.1 Indoor Fan Function**

### **5.1.1 Indoor Coil Anti-Freezing Function**

The function utilizes the indoor coil sensor(T2) to determine whether the indoor coil is freezing or not. The feature prevents the unit running at low evaporating temperature as well as low suction superheat.

When all the following conditions are met, the Anti-Freezing Function will activate:

- A.  $T2 < 32^{\circ}\text{F}$
- B.  $32 - T2 \geq 5.4$

when the following conditions are met, the Anti-Freezing Function will deactivate:

- A.  $T2 \geq 42.8^{\circ}\text{F}$

When the feature is activated, the compressor will be turned off.

### **5.1.2 R454B Leakage Detection Function**

The function utilizes a R454B refrigerant sensor to detect the R454B concentration. Terminal F is reserved for connecting buzzer if needed.

When R454B leakage occur in the indoor coil and the concentration is above 10%, the unit will perform as the following:

- A. Cut off power to thermostat to stop compressor from continuing operation.
- B. Electric Heat kit will be turned off.
- C. High voltage will be output between terminal F and terminal L2 and the buzzer will be turned on.

# 6. Ductwork

On-site ductwork must comply with National Fire Protection Association NFPA 90A, NFPA 90B and any applicable local ordinance(s).



### Warning: Fire and carbon monoxide

- Under no circumstances should the return ductwork be connected to any other heat-producing equipment, such as mantelpiece, stove, etc. Unauthorized use of such equipment may cause fire, carbon monoxide poisoning, explosion, personal injury or property damage.

The metal ductwork operating in the air-conditioned space must be insulated and covered with a moisture-proof layer. If the construction and installation are carried out according to SMACNA glass fiber duct construction standard, the fiber duct system can be used. The ductwork must meet the U/L standard 181 test of Class I air duct by National Fire Protection Association of America. Check the local regulations of ductwork and insulation requirements.

- The duct system must be designed within the external static pressure range of the designed operation of the device. Adequate airflow in the system is very important. Ensure that the supply and return ductwork, grid, special filter screen, accessories, etc. are included in the total resistance. Please refer to the airflow performance table in Section 5 of this manual.
- Design the ductwork according to "ACCA" manual "D" residential air conditioning design and equipment selection in winter and summer. The latest version can be obtained from "ACCA" American Air Conditioning Contractors Association, 1513 16th Street NW, Washington, DC, 20036. If the ductwork contains flexible air pipes, make sure that the system takes into account the pressure drop information (straight line length plus all turns) shown in "ACCA" manual "D".
- The air duct connector should be connected to the 3/4 "flange on the equipment. Install a flange around the air outlet.



If the duct connector has an elbow, its size should not be smaller than that of the flange on the outlet of the device.



The front flange on the return duct (if connected to the fan casing) must not be screwed into the area where the power cord is located. Drill bits or sharp screw tips can damage the insulation of the internal wires of the equipment.

- Use appropriate fasteners suitable for the type of duct used, fix the outlet and return ducts to the flanges of the device, and connect the ducts to the device with adhesive tape as needed to prevent air leakage.

# 7. Refrigerant Pipe Connection

Before the refrigerant pipe connection is completed, keep the coil sealed. Please refer to the installation, operation and maintenance manual of the external machine for detailed information on refrigerant line size, duct installation and filling amount.

Pull out the rubber plugs and check whether there is nitrogen flowing out.



## Warning: Personal injury hazard

- Failure to follow this warning could result in personal injury.
- Wear eye protection.



## Note:

- Factory nitrogen charge may escape past rubber plugs during storage. This does not indicate a leaking coil nor warrant return of the coil.

Care should be taken to connect the refrigerant pipe so that it will not obstruct the maintenance channel in front of the equipment.

Before brazing, the metal 1 and 2 need to be uninstalled. See Figure 7.1.

Pull out the evaporator (6 inches) so that longer refrigerant line could be exposed for wet rag and brazing.

During brazing, nitrogen should flow through the refrigerant pipe. Use a brazing shield to protect the paint of the cabinet, and use a wet rag to protect the rubber gasket of the pipeline from being damaged by the torch flame. During the brazing process, protect the temperature sensing bulb of TXV with wet cloth or approved heating paste. See Figure 7.1.

After brazing, pull in the evaporator and put the metal 1 and 2 back to the cabinet.

After the refrigerant pipeline connection is completed, seal and fill the surrounding gaps with pressure-sensitive gaskets.

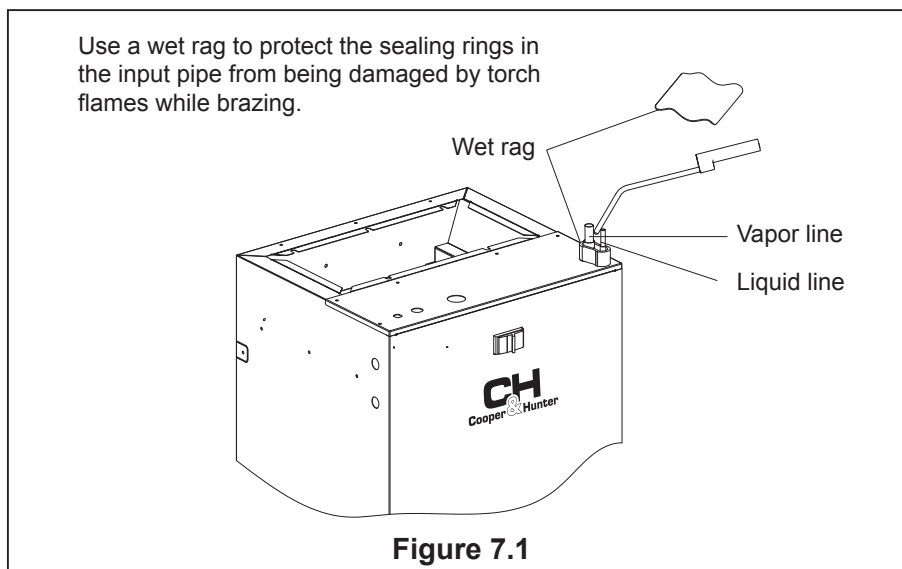

### Note: Maintain pressure with inert gas



- That after completion of field piping for split systems, the field pipework shall be pressure tested with an inert gas and then vacuum tested prior to refrigerant charging, The minimum test pressure for the system shall be the low side design pressure (See nameplate for detail).

After brazing, make sure that there is no refrigerant leakage. After checking the vapor leakage, make sure that the pipeline is insulated, as shown in Figure 7.2.

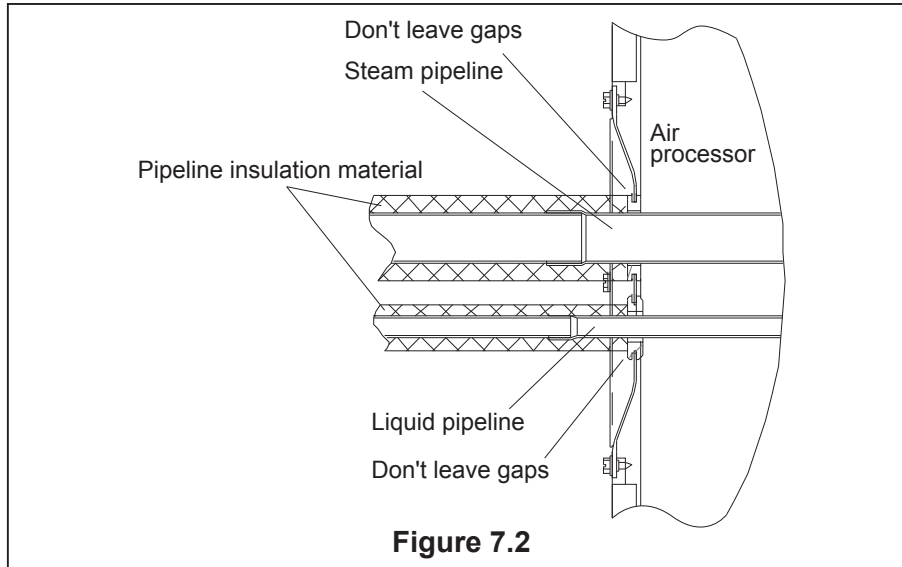

## 7.1 Condensate Drain Connection

The unit is supplied with primary and auxiliary condensate drains that have 3/4" NPT connections. Both drains must be trapped outside the unit and piped in accordance with applicable materials and building codes. Condensate should be piped to an open drain or to the outside.

For specific requirements, please consult local codes.

For the required condensate trap installation, please refer to Figure 7.3 and the following information.

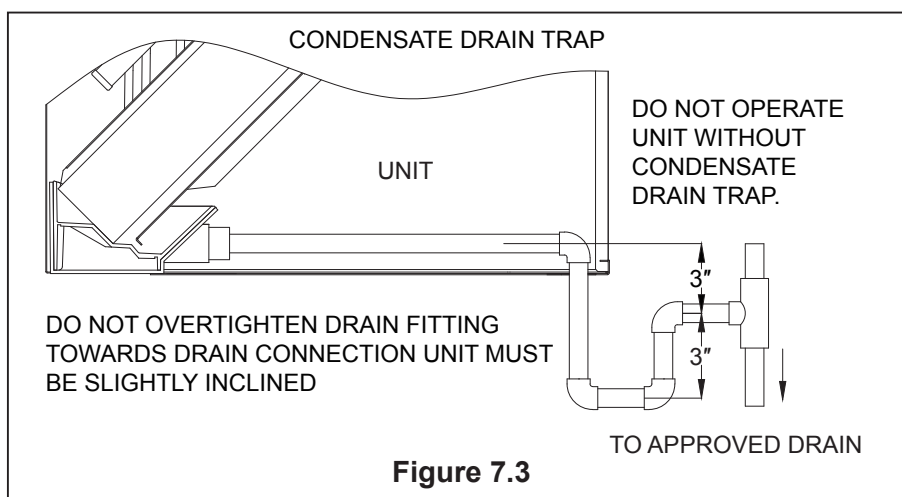



1. When connecting the drain connector to the drain pan, use a thin layer of PTFE paste, silicone or PTEF, and tighten it by hand.
2. When connecting the drain connector to the drain pan, don't over tighten it. Tight fittings will crack the pipe connection on the drain pan.
3. Important: If cleanout Tee is used, standpipe must be sealed/capped.

- Make sure that the drainage pipe will not block the inlet in front of the device. The minimum clearance required for removal and maintenance of filter screen, coil or fan is 24 inches.
- Make sure that the machine is placed horizontally or slightly inclined to the main drain outlet, so that water can be completely drained from the machine.
- Do not reduce the drain pipe size to less than the connection size provided on the condensate drain pan.
- All horizontal drainage pipes must be inclined downward at a slope of at least 1/8 inch per foot to ensure proper drainage.
- Do not connect the condensate drain line to the closed or open sewage pipe. Drain the condensate to an open drainage pipe or to a safe outdoor area.
- Where necessary, the drainage pipeline should be insulated to prevent damage caused by condensation water formed on the outer surface of the pipeline.
- If necessary, be prepared to disconnect and clean the main drainage pipe. Install a 3-inch elbow on the main drainage pipe as close as possible to the unit. Make sure that the top of the elbow is lower than the joint of the drain pan to allow the drain pan to drain completely (see Figure 7.3).
- Auxiliary drainage pipes should be extended to places where condensate can be easily seen. If the condensed water starts to flow out from the auxiliary drain pipe, the homeowner should pay attention to the possible problems.
- Plug the unused drain connector with the plug in the parts package provided with the equipment. Use a thin layer of Teflon paste, silicone or Teflon tape to form a waterproof seal.
- After installation, test the condensate drain pan and drain pipe. Pour water into the drain pan, enough to fill the drain traps and pipes. Check to ensure that the drain pan completely drains water, no leakage is found in the drain pipe fittings, and water is discharged from the main drain pipe terminal.

## 8. Air Filter (Not Factory Installed)

The filter is not included in the device and must be provided on site.

The size of external filters or other filtering devices must meet the maximum flow rate of 300ft/min, or meet the recommended value of filter type.

The application and placement of filter is very important for airflow, which may affect the performance of heating and cooling system. Reduced airflow will shorten the life of the main components of the system, such as motors, components, thermal relays, evaporator coils or compressors. Therefore, we recommend that the return air duct system has only one filter position. For systems without return air filter grids, multiple filter grids can be installed at each return air opening.

If a high-efficiency filter screen or electronic air filtration system is used, it is very important that the air flow rate is not reduced. If the air flow decreases, the overall performance and efficiency of the device will decrease. It is strongly recommended to contact professional installation technicians to ensure the correct installation of such filtration systems.



Do not double filter the return air system. Do not filter the air supply duct system. This will change the performance of the device and reduce the airflow.



### Warning: Fire risk

- Do not operate the system without a filter. Part of the dust suspended in the air may temporarily stay on the duct and the air outlet of the room. Any circulating dust particles may be heated and burnt due to contact with AHU elements. This residue will stain the ceiling, walls, curtains, carpets and other items in the house. When some types of candles, oil lamps or igniters burn, soot may be generated in the filter.

# 9. Filter

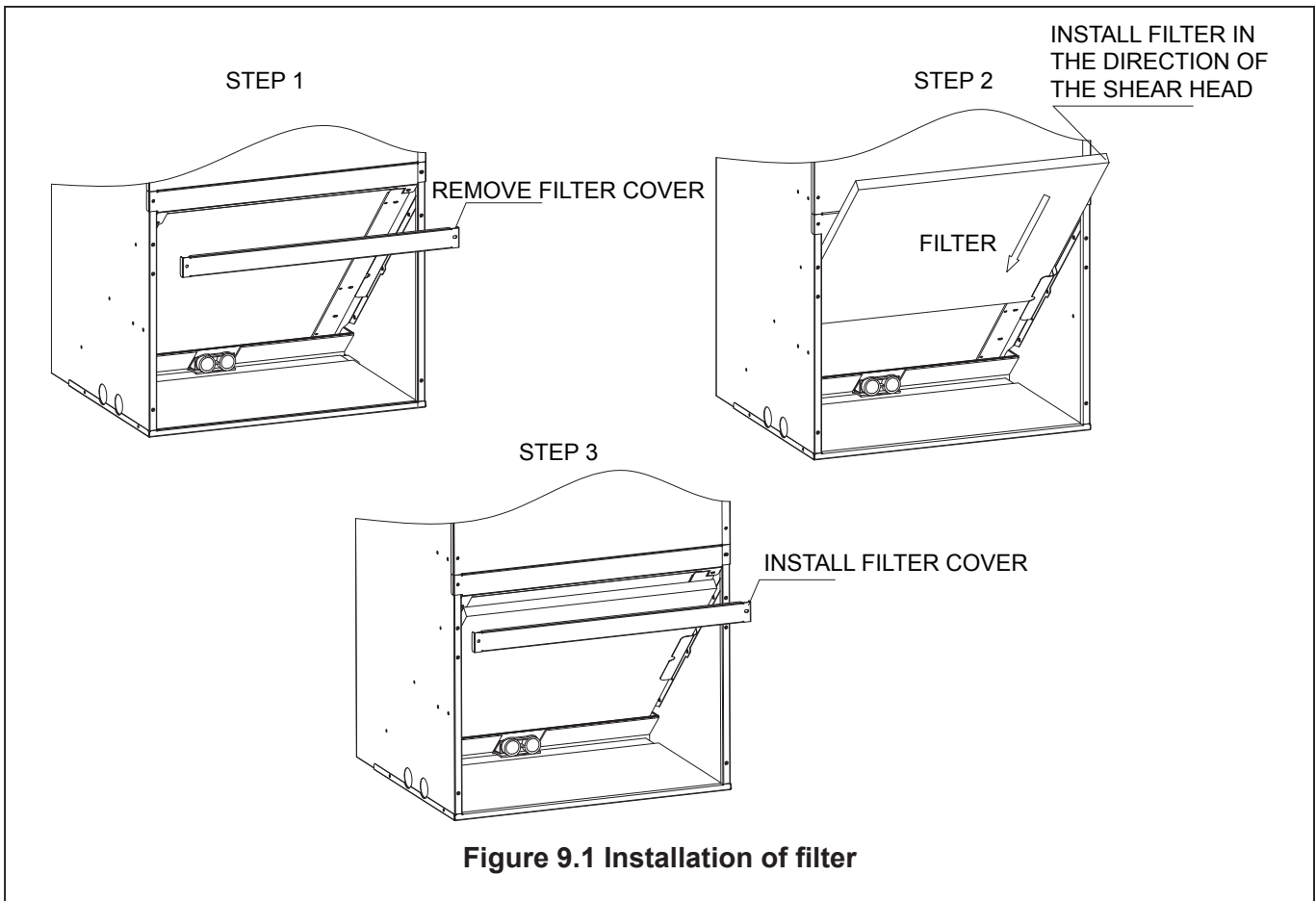

**i** The filter is not included in the device and must be provided on site.

**Table 9.1 Size of Filter**

Model	Filter size inches [mm]
18K/24K	16×20[406×508]
30K/36K	20×20[508×508]

## Removal/Installation of Air Filter

- Manually remove the bolts and remove the filter cover, as shown in Figure 9.1.
- Hold the edge of the strainer and pull it out.
- Install a new filter so that the arrow on the filter screen is consistent with the airflow direction.
- If a reusable filter is used, please clean it according to the manufacturer's specifications before re-installing it.
- The filter needs to meet UL 900.

# 10. Maintenance



In order to keep high performance and minimize possible equipment failures, the equipment must be regularly maintained.

## 10.1 Cleaning Precautions



### Warning:

- Any equipment maintenance can only be carried out by qualified maintenance personnel.



### Warning: Before cleaning and maintenance

- Before cleaning or maintenance, be sure to turn off the equipment and disconnect its power supply.



### Be careful:

- When removing the filter, do not touch the metal parts in the device. Sharp metal edges can cut you.



### Note:

- Do not use chemicals or chemically treated cloth to clean the equipment.
- Do not use benzene, paint thinner, polishing powder or other solvents to clean this machine.
- Do not operate the system without a filter.

## 10.2 Routine Maintenance

Your equipment must be inspected regularly by qualified service technicians. Your annual system check must include:

1. Check the filter every 90 days, or at any time as needed. If it is blocked or block, please clean or replace it immediately.
2. Inspection and/or cleaning of impeller housing and motor.
3. Check and clean indoor and outdoor coils as needed.
4. Check and/or clean indoor coil drain pan and drain pipe and auxiliary drain pan and pipe.
5. Check all wires and connections. Refer to the wiring diagram and make corrections as needed.

# 11. Wiring Diagram



## Warning: Electric shock

- Before repairing or installing this device, please disconnect all power supplies. There may be multiple power sources. Otherwise, property damage, personal injury or death may result.



## Danger: Electric shock

- The device must be properly grounded and protected by a circuit breaker or fuse.



## Warning: Electric shock

- These devices must be wired and installed according to all national and local safety codes.

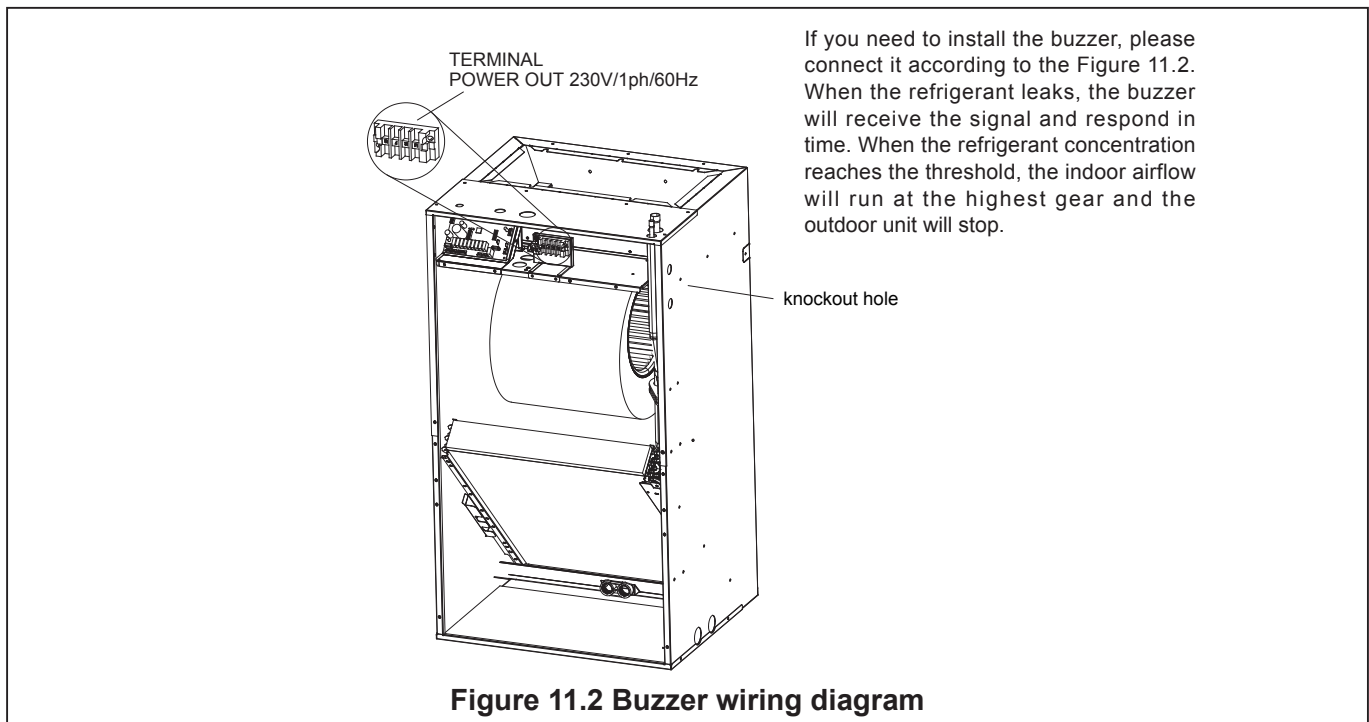

- To avoid electric shock, make sure:
  - 1) Equipment is properly grounded.
  - 2) The main power plug of the device has been connected to the ground wire (do not change it).
- Do not tighten the power cord.



The dotted line in the following thermostat wiring diagram indicates optional wiring (wiring for passive dehumidification function and/or electric heating). For the wiring of the thermostat, please refer to the user manual of the thermostat.

### Wiring for 3H and 2C thermostat

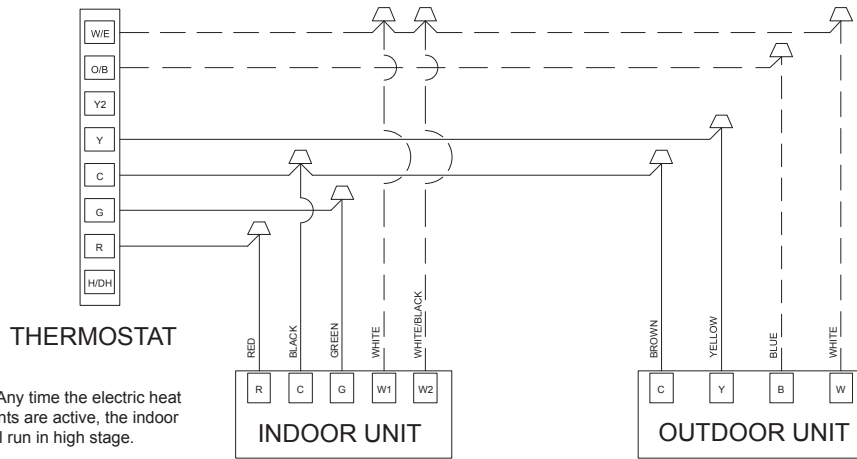

**Figure 11.3 Control Wiring**

### Wiring for 4H and 2C thermostat

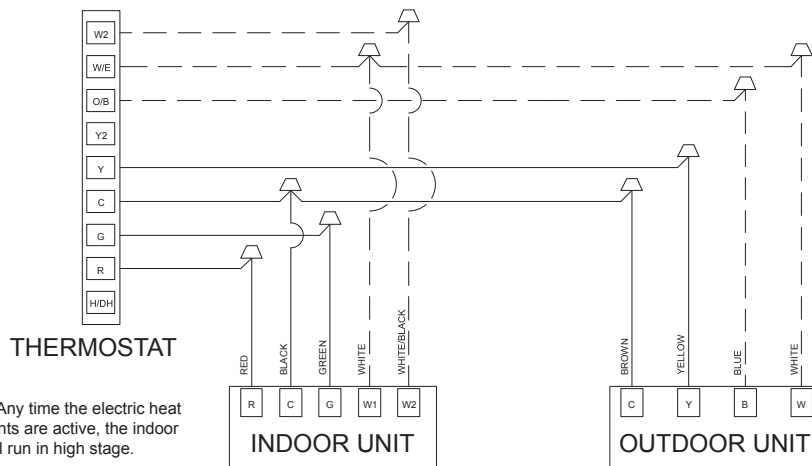

**Figure 11.4 Control Wiring**

### Wiring for 3H and 1C thermostat

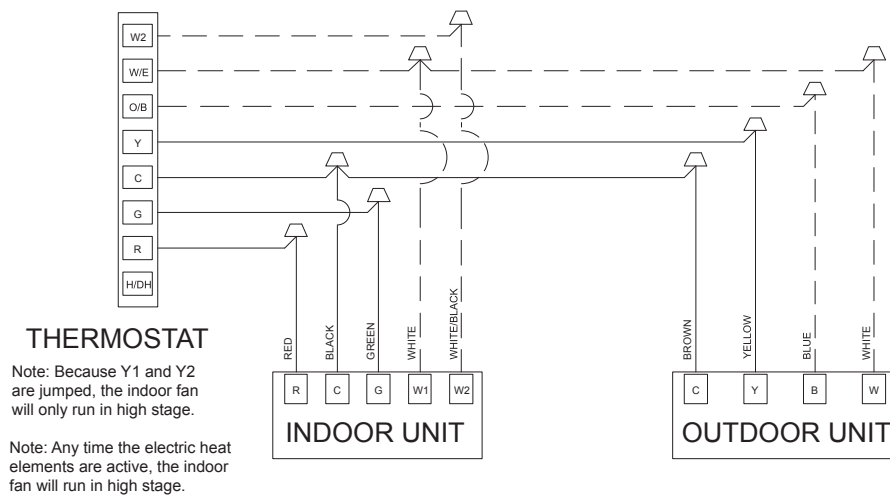

**Figure 11.5 Control Wiring**

Wiring for 2H and 2C thermostat

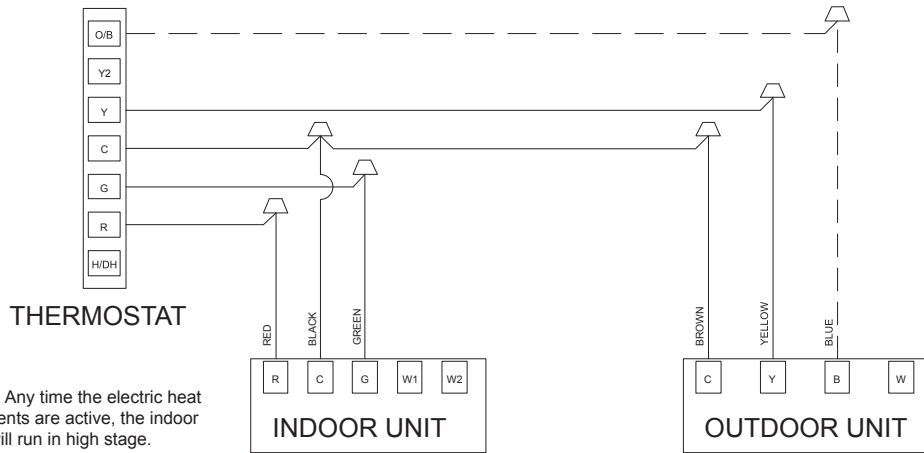

Note: Any time the electric heat elements are active, the indoor fan will run in high stage.

Figure 11.6 Control Wiring

Wiring for 1H and 1C thermostat

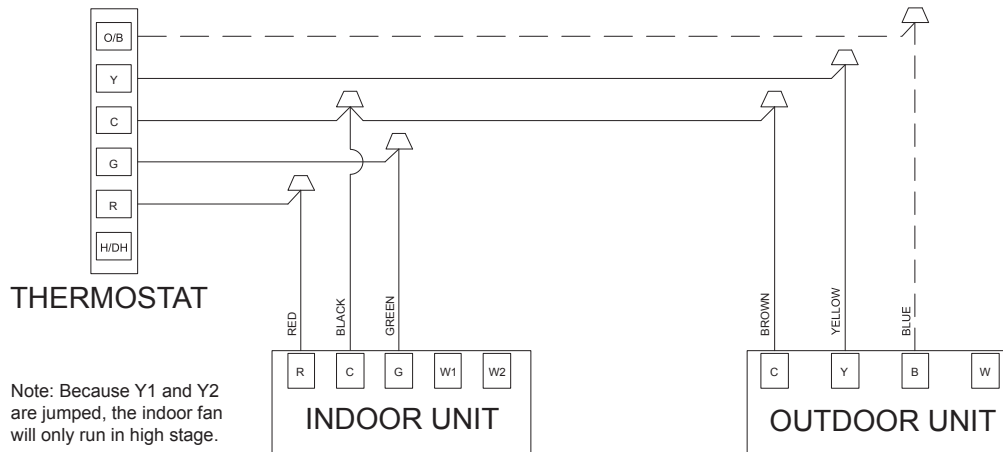

Note: Because Y1 and Y2 are jumped, the indoor fan will only run in high stage.

Figure 11.7 Control Wiring

Wiring for 2H and 1C thermostat

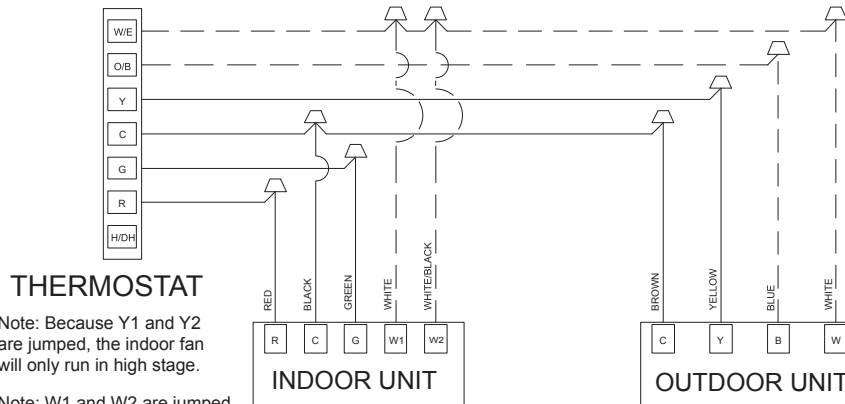

Note: Because Y1 and Y2 are jumped, the indoor fan will only run in high stage.

Note: W1 and W2 are jumped, so Electric Heat will only function in high stage.

Figure 11.8 Control Wiring

**Table 11.1 Wire Gauge of High Voltage System**

Type (Btu/hour)		18K	24K	30K	36K	
Power	Stage	Single				
	Voltage/frequency	208/230VAC, 60 Hz				
Wire gauge	Indoor unit power cord	Line quantity	3	3	3	3
		Wire diameter (AWG)	16	16	16	16
	Outdoor unit power cord	Line quantity	3	3	3	3
		Wire diameter (AWG)	14	14	12	12

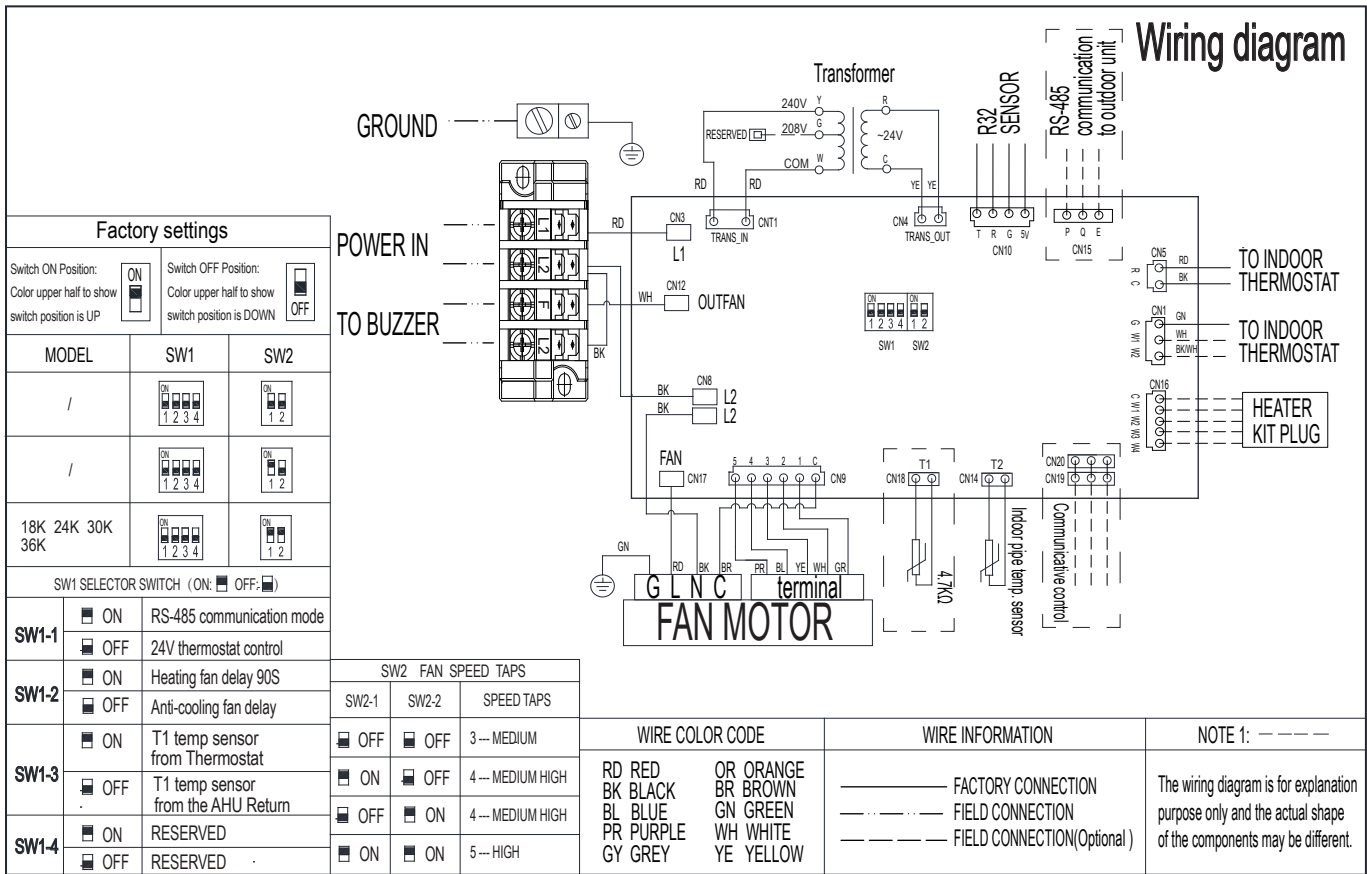

Applicable to 18K/24K/30K/36K

**NOTE:** For reference only, the actual wiring diagram shall prevail.



## Technical Support

Single & Multi-Zone Mini Splits • PTACs • Portables •  
TTWs • Light Commercial A/C Systems

Limited Warranty provided by Cooper&Hunter (hereby referred to as C&H) covers specified products and parts, subject to the following details:

### **Our warranty:**

C&H Limited Warranty applies only to products installed by a licensed HVAC technician.

**Product Registration:** Products must be registered for Limited Warranty within 60 days of installation by licensed HVAC technician. Products can be registered at [www.cooperandhunter.us/warranty](http://www.cooperandhunter.us/warranty). Alternatively, the warranty registration card from the product User's Manual can be filled out and sent in as instructed.

**Warranty Coverage:** Cooper&Hunter distributor warrants this product against failure due to defect in materials or workmanship under normal use and maintenance as follows. All warranty periods begin on the date of original installation. Damage resulting from failure to use, install or maintain the product in a manner consistent with manufacturer's recommendations shall render the warranty void. Cooper&Hunter, at its discretion, may request a report from a qualified technician prior to honoring a warranty claim. If a part fails due to defect during the applicable warranty period, Cooper&Hunter will provide a new or remanufactured part, at C&H's discretion, to replace the failed defective part at no charge. This Limited Warranty is subject to all provisions, conditions, limitations and exclusions listed below.

- Warranty is provided only to the first original owner of the Product, where it is originally installed, and is not transferable to the subsequent owners
- Limited Warranty applies only to systems properly installed by a state certified or licensed HVAC contractor, under applicable local and state law, in accordance with all applicable building codes and permits, C&H installation and operation instructions and good trade practices
- Warranty applies only to products remaining in their original installation location
- Defective parts must be returned to the distributor through a registered servicing dealer for credit

*This warranty gives you specific legal rights. Rights may vary from state to state or province to province. For complete warranty details and duration of your specific product, please visit our website at [cooperandhunter.us/warranty](http://cooperandhunter.us/warranty) and follow the registration instructions.*

### **LIMITATIONS OF WARRANTIES:**

**ALL IMPLIED WARRANTIES AND/OR CONDITIONS (INCLUDING IMPLIED WARRANTIES OR CONDITIONS OF MERCHANTABILITY AND FITNESS FOR A PARTICULAR USE OR PURPOSE) ARE LIMITED TO THE DURATION OF THIS LIMITED WARRANTY. SOME STATES OR PROVINCES DO NOT ALLOW LIMITATIONS ON HOW LONG AN IMPLIED WARRANTY OR CONDITION LASTS, SO THE ABOVE MAY NOT APPLY TO YOU. THE EXPRESSED WARRANTIES MADE IN THIS WARRANTY ARE EXCLUSIVE AND MAY NOT BE ALTERED, EXTENDED, OR CHANGED BY ANY DISTRIBUTOR, DEALER, OR OTHER PERSON, WHATSOEVER.**

**Warranty Exclusions:** Cooper&Hunter is not responsible for any warranty claim:

1. For equipment installed outside of North America.
2. For equipment not installed according to manufacturer's guidelines.
3. For equipment which has been removed from the original place of installation and reinstalled at another place.
4. If registration information cannot be verified (i.e., invalid license number or wrong information provided).
5. For damages or repairs arising as a result of a faulty installation, inappropriate application, or improper use.
6. For damages or repairs arising from any external perils, out of Cooper&Hunter's control, such as fires, storms, accidents, floods, broken or frozen water pipes, electrical surges, input power with under or overvoltage, lightning, or existence of corrosive substances nearby.
7. For damages or repairs arising from use of non-compatible parts, third-party components, alterations, modifications, or improper applications.

8. For improper service or poor maintenance of the equipment, such as cleaning of all air filters, heat exchangers, fans, and blowers, in addition to any necessary lubrication of internal components and maintenance of external accessories.
9. For changes that can be considered cosmetic, including but not limited to small fin damages, scratches on the unit cover, etc.
10. For resetting of power or the circuit breakers and replacement of other types of fuses, both internal and external.
11. For any damage caused by the use of dirty, recycled, or wrong type of refrigerants and lubricants.
12. For damage due to moisture, air, dust, sand, dirt, etc., that have been allowed into the system.
13. For damage caused by continuing use of the product after a malfunction has been noticed or indicated at the display module, through an error code.
14. For damages or performance issues due to improper matching, product selection, undersizing, oversizing, improper installation, or misuse.
15. For loss or replacement of refrigerant, lubricant, or oil.
16. For labor or any costs associated with labor.

**Warranty Begin Date:** Warranty begins on the date of registration.

**Warranty End Date:** Products that have not been registered as instructed above are not covered under Warranty. The Warranty duration will vary from product to product and may have additional extensions granted through promotional benefits. Any part, component or product that is replaced under the terms of this Warranty, will be covered under the same Warranty for the duration in which the original Warranty was applicable. Please visit our website at [cooperandhunter.us/warranty](http://cooperandhunter.us/warranty) and follow the registration instructions to find specific details on your product warranty.

**Warranty Procedure:** The product owner or technician should contact **Cooper&Hunter Technical Support at (888) 293-9252, Monday to Friday from 9AM to 5PM EST** while the technician is on site servicing the unit. The product may display error codes. The technician should be on site while troubleshooting with the C&H Technical Support Agent so he or she can address symptoms observed, specific electrical and mechanical measurements, and other detailed information that may be required for proper diagnosis.

While technicians may refer to Cooper&Hunter's website or YouTube channel for helpful information, such as manuals and videos based on certain error codes, the technician will need to troubleshoot with the C&H Technical Support Agent for Warranty purposes. Cooper&Hunter is not able to remotely diagnose a product and or offer remedies, without proper diagnosis results.

When contacting Technical Support, the following forms and information need to be provided:

1. Unit's Model & Serial number
2. Date of Unit Installation by a Licensed Technician
3. Installer's EPA License Number
4. Place Unit was purchased

Cooper&Hunter may ask for photos and/or other diagnostic information it deems necessary prior to processing the Warranty claim.

It should be noted that C&H Technical Support Agents troubleshoot on a case-by-case basis, following best practices and procedures to diagnose problems and solutions. Through this process, it is most efficient to diagnose one issue or error code at a time. It is possible that the first suggested solution may or may not solve one problem of multiple failures, in which case the Technician will continue through troubleshooting for remaining issues/error codes.

Cooper&Hunter will furnish a new or refurbished part without any charge for the part itself, for the replacement of any part that has been determined, by Cooper&Hunter, to have failed, at its sole discretion, due to defects in its materials or workmanship under standard use and proper maintenance. The payment of the shipping costs for the part will be the sole responsibility of the owner of the product. Cooper& Hunter reserves the right to ask the owner of the product to return the failed part before or after a replacement part is sent out.

**Labor cost, materials and other costs:** Any labor costs and/or the costs for the supplies or materials used or purchased in the field for the replacement of the defective part, remain the responsibility of the owner. No other costs involved in diagnosis, lodging, transportation, servicing, repair, replacement, installation, removal, shipping, etc., are to be covered under the Warranty.

**Refrigerant:** Any costs related to charging, recharging, adjustment, or removal of refrigerant, and the cost of the refrigerant itself, are not covered under any circumstances. All products go through vigorous quality controls at various stations and leave the factory in perfect working and sealed condition. Products are individually tested in highly sensitive helium vacuum chambers for existence of refrigerant leaks. Cooper&Hunter does not cover any claims related to the lack of refrigerant in new products, discovered upon arrival, or during installation, as well as subsequent refrigerant loss occurring at any time afterward.

This Warranty is not transferable. No person or entity is authorized to change the terms and conditions outlined in this Warranty agreement, in any respect, nor to create any additional obligations or liabilities for any party involved.

This warranty agreement supersedes all prior warranty agreements between the parties and constitutes the complete, final and exclusive understanding of the parties with respect to the subject matter. All prior negotiations, representations, or promises, whether oral or written, of either party shall be deemed to have been merged herein.

If any part of this warranty agreement shall be invalidated for any reason, such part shall be deleted, and the remainder shall be unaffected and shall continue in full force and effect. This Warranty provides you certain legal rights and you may also have other rights, which vary from State to State. Therefore, some of these limitations or exclusions may not apply to you.

**States with Express and Implied Warranties:** Products in states with Express and Implied Warranties do not need to be registered for C&H Warranty. However, for Warranty support, installation invoice should be provided.

**Pursuing legal remedies:**

ARBITRATION CLAUSE. IMPORTANT. PLEASE REVIEW THIS ARBITRATION CLAUSE, AS IT AFFECTS YOUR LEGAL RIGHTS.

1. This arbitration clause affects your rights against Cooper&Hunter and any of its employees, agents, affiliates, successors, or assignees, all of whom together are referred to below as “we” or “us” for the simplicity of reference.
2. **ARBITRATION REQUIREMENT: EXCEPT AS STATED BELOW, ANY DISPUTE BETWEEN YOU AND ANY OF US SHALL BE DECIDED BY NEUTRAL AND BINDING ARBITRATION, RATHER THAN ANY COURT OR BY TRIAL BY JURY. ARBITRATION WILL BE HANDLED ONLY ON AN INDIVIDUAL BASIS AND ALL PARTIES EXPRESSLY WAIVE; ANY RIGHTS TO PARTICIPATE AS A CLASS REPRESENTATIVE OR CLASS MEMBER, ANY RIGHTS TO CLASS ARBITRATION OR ANY CONSOLIDATION OF INDIVIDUAL ARBITRATIONS. THE ARBITRATOR WILL BE A MEMBER OF THE AMERICAN ARBITRATION ORGANIZATION.** The meaning of “Dispute” has the broadest possible meaning allowable by law, including any controversy, claim or other dispute, relating to or arising from the purchase of the product, any of the warranties upon the product, or the condition of the product, as well as the determination of the application or the scope of the Arbitration Clause itself. Rights to appeal and discovery are also limited in arbitration based on the rules of the arbitration organizations.
3. **Governing Law:** Effect and procedures of arbitration will be governed by the Federal Arbitration Act (9 U.S.C. § et seq.) rather than any related state law. In case of any substantive warranty, your claims and rights under such substantive warranty will be governed by the applicable law of the state in which Product was purchased.
4. **Location of the Arbitration:** Unless otherwise provided under the applicable law, arbitration hearing will be conducted in the judicial district in Miami-Dade County, Florida.
5. **Costs of the Arbitration:** Unless otherwise provided under the applicable law, each party will be responsible for; its own costs payable to the arbitration organization, and the costs of their attorneys, experts or other fees.
6. **Survival and Enforceability of the Arbitration Clause:** This arbitration clause will survive the expiration or termination of this warranty agreement, indefinitely.

**CH**  
**Cooper & Hunter**  
01.19.2026