

CH
Cooper & Hunter



CHV 6 CATALOG 2026



URBAN
VRF

R 3 2 S E R I E S



ABOUT



COOPER&HUNTER

With more than 25 years of experience in air conditioning and ventilation, Cooper&Hunter has grown into a leading HVAC market player. The brand is dedicated to technological innovation and consumer-driven product development, generating HVAC equipment that adheres to the highest quality standards, providing reliable, energy-efficient, and cost-effective air conditioning solutions.

While products under the Cooper&Hunter brand are distributed in more than 55 countries worldwide, the brand's growth within the US market has been rapid. Cooper&Hunter stands out from big-name brands by providing quality support to customers and technicians alike, with their in-house technical support team offering troubleshooting and warranty support Monday through Friday from 9am to 5pm in 5 different languages (including English, Spanish, Mandarin, Russian, and Ukrainian).



© 12.2025 All rights reserved.

COOPER&HUNTER SPONSORSHIPS

Cooper&Hunter is proud to sponsor the New York Yankees, NASCAR, Florida Panthers, and Miami Zoo because these partnerships reflect our commitment to excellence, innovation, and community engagement. The New York Yankees represent a storied legacy of success and ambition, while NASCAR embodies the thrill of speed and precision engineering—both values we share. Supporting the Florida Panthers aligns with our dedication to teamwork and perseverance, and our partnership with the Miami Zoo highlights our commitment to environmental sustainability and education. Together, these sponsorships allow us to connect with diverse audiences, celebrate shared values, and foster a sense of community across different arenas.

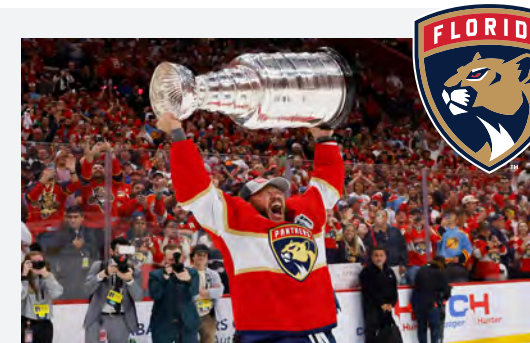

Florida Panthers Celebrate Victory!

Once again, Cooper&Hunter has re-newed our Sponsorship Agreement with the Florida Panthers. Just Recently, after a 30-year journey, the Panthers finally etched their name in hockey history, avoiding a collapse after losing three consecutive games. The Florida Panthers clinched their first-ever Stanley Cup title! In a thrilling Game 7 showdown against the Edmonton Oilers, the Panthers secured a hard-fought 2-1 victory.



HVAC Meets High-Octane!

We are thrilled to continue our sponsorship with MBM Motorsports, a team we deeply admire and respect for their achievements and values. Supporting **Chad Finchum**, an HVAC Technician, Client, and Nascar Driver, who has consistently demonstrated his skills and talent in the sport, is a source of pride for us. We believe this partnership perfectly represents the synergy between HVAC excellence and NASCAR speed.



Home Run Collaboration!

Cooper&Hunter is thrilled to announce our renewed sponsorship of the New York Yankees! They did an outstanding job in 2024, winning the East and American leagues again. We are confident that this partnership will continue to thrive in 2025. Our collaboration with the Yankees aligns perfectly with our brand's values of striving for excellence and innovation. We look forward to supporting the team in their future endeavors and continuing to engage with the community through this prestigious partnership.

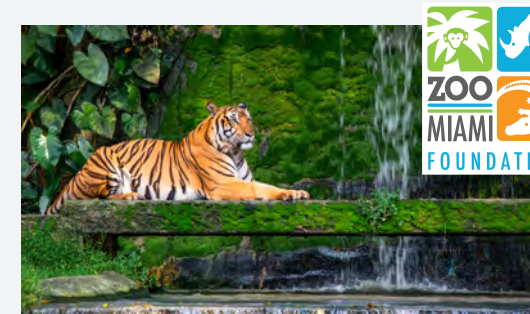

Chilling with Nature!

Cooper&Hunter is proud to sponsor the Miami Zoo Foundation, the non-profit partner of Zoo Miami. This sponsorship aligns with Cooper&Hunter's mission to support wildlife conservation, environmental sustainability, and community engagement. Additionally, as HVAC experts, Cooper&Hunter has provided Astoria units for optimal climate control in various animal habitats, ensuring a comfortable and healthy environment for the animals.



Cooper&Hunter CHV6 features the environmentally friendly R32 refrigerant in its VRF systems, offering an ideal solution for meeting CO₂ emission goals. We are determined to become create a sustainable future together with you.

Features:

- Zero Ozone Depletion Potential (ODP)
- Less charge amount under the same capacity
- Lower Global Warming Potential (GWP)
- Single component refrigerant, easy to handle and recycle
- Refrigerant Leakage Sensor
- Refrigerant Recovery Shut Off Box
- High-efficiency DC Inverter Compressor



Max height difference between ODU and IDU: **164 ft.**

Max height difference between IDUs: **49 ft.**

Note: 131 ft. if the ODU is below the IDU

Max Piping Length: **262 ft.**
Total Length of Pipes: **590 ft.**

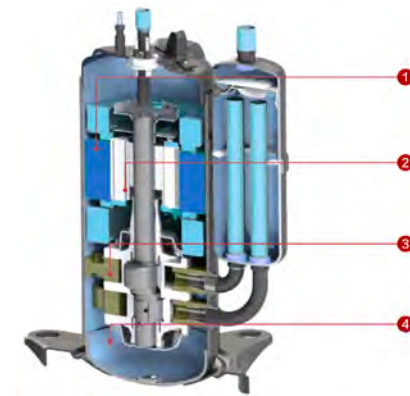

- 1. High-efficiency motor**
Optimize the motor design to improve compressor performance.
- 2. Optimized rotor design**
Lower the gravity center of the compressor to reduce vibration and noise
- 3. Flat mechanism design**
Improve the volumetric efficiency and the total performance.
- 4. Screw interactive fastening**
Improve fastening effect and reduce deformation of the core.

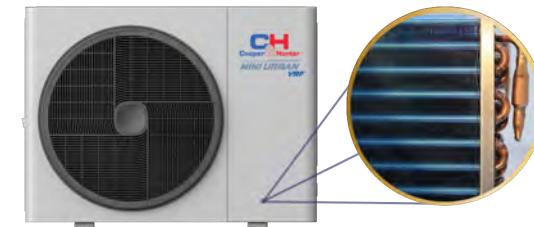

Bottom Anti-frosting Structure

To ensure effective frost removal, the heat exchanger circuit extends to the bottom, preventing melted frost from solidifying again as it reaches the condensate drain, which promotes smooth discharge. Additionally, this extension prolongs the frost formation period, extending the defrost interval.

Wind Guard

By reducing heat transfer with the chilly outdoor air during winter, the **Wind Guard** preserves indoor warmth, curtails energy consumption, diminishes repair expenses, and ensures optimal efficiency and performance.



Reliable Performance in Low Temperatures

The heating capacity of the R32 CHV6 Mini Urban Series keeps stable and consistent at extreme low temperatures, maintaining 70% capacity when the temperature reaches -5°F*.

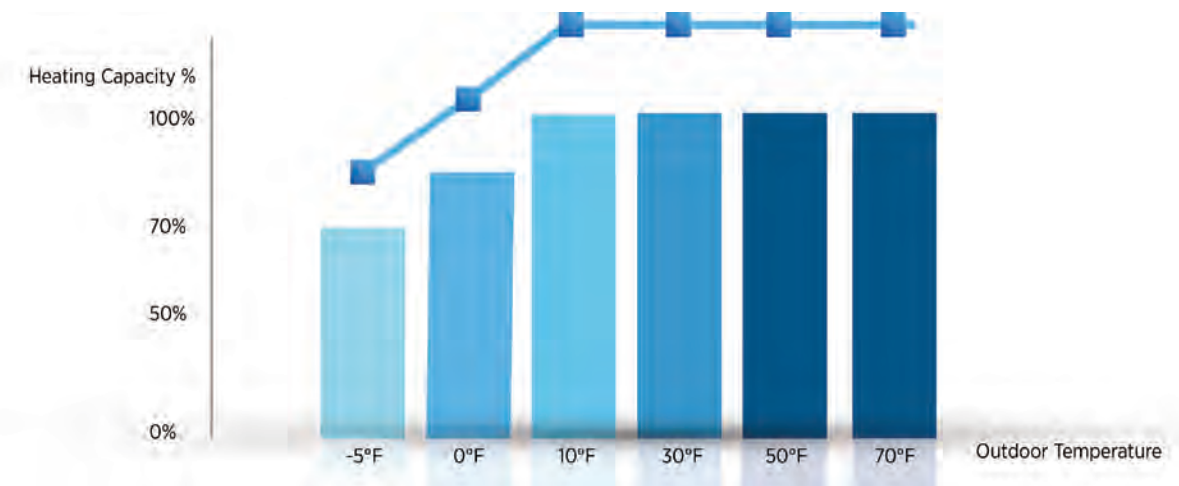

* To ensure 70% heating capacity for 2-3 Ton at the temperature of -5°F, wind shield is required.



THE R32 CHV6 MINI URBAN SERIES OFFERS EXPANSIVE OPERATIONAL RANGES WITH MORE STABLE PERFORMANCE.

In addition to Optimal performance, the R32 CHV6 Mini Urban Series offers great space efficiency along with cost optimization. Its sleek, light weight and compact form minimizes the space needed, enabling versatile installation even in tight areas.

STANDARD EFFICIENCY

Model Name			CHV6-RS24URBM	CHV6-RS36URBM	CHV6-RS48URBM
Nominal Tonnage		RTU	2	3	4
Capacity	Cooling	Btu/h	27,000	36,000	48,000
	Heating	Btu/h	27,000	42,000	54,000
Input Power (Ducted/Non-Ducted)		kW	2.09/2.00	3.19/2.86	5.16/4.00
EER (Ducted/Non-Ducted)		Btu/h/W	11.5/12.0	11.3/12.6	9.30/12.0
SEER2 (Ducted/Non-Ducted)		Btu/h/W	18.15/18.15	17.0/23.0	17.0/23.3
Power Supply		V/Ph/Hz	208-230V / 1Ph / 60Hz		
Electrical Parameters	MCA	A	20.9	26.5	30.0
	MOP	A	30	40	45
Max Connectable Indoor Units		Qty	4	9	11
Sound Pressure Level (Cooling/Heating)		dB(A)	49/51	52/54	53/55
Dimensions	H		33.70	33.70	33.70
	W		43.31	43.31	43.31
	D		15.35	15.35	15.35
Connection Pipe Diameter	High/Low Pressure Gas Pipe	in.	5/8	5/8	5/8
	Liquid Pipe		3/8	3/8	3/8
Refrigerant			R32		
Compressor			Rotary		
Compressor Quantity		PC	1	1	1
Weight	Net Weight	lbs.	190	202	202
	Gross Weight		224	235	235
Piping Design	Height Diff between ODU and IDU	ft.	164		
	Height Diff between IDUs		49.0		
	Total Pipe Length		590		
	Max Piping Length		262		
Operation Range	Cooling	°F	23-122		
	Heating	°F	-13-78		

HYPER HEAT EFFICIENCY

Model Name			CHV6-RS36URBMHH	CHV6-RS48URBMHH	CHV6-RS60URBMHH
Nominal Tonnage		RTU	3	4	5
Capacity	Cooling	Btu/h	36,000	48,000	60,000
	Heating	Btu/h	42,000	54,000	63,000
EER (Ducted/Non-Ducted)		Btu/h/W	11.5/12.5	11.0/12.0	10.5/11.0
SEER2 (Ducted/Non-Ducted)		Btu/h/W	17.5/22.5	17.5/22.0	17.0/21.5
Power Supply		V/Ph/Hz	208-230V / 1Ph / 60Hz		
Electrical Parameters	MCA	A	29.7	39.6	41.8
	MOP	A	40	50	60
Max Connectable Indoor Units		Qty	9	11	12
Sound Pressure Level (Cooling/Heating)		dB(A)	50/53	52/54	57/58
Dimensions	H		54.34	54.34	54.34
	W		37.40	37.40	37.40
	D		14.56	14.56	14.56
Connection Pipe Diameter	High/Low Pressure Gas Pipe	in.	5/8	5/8	5/8
	Liquid Pipe		3/8	3/8	3/8
Refrigerant			R32		
Compressor			Rotary		
Compressor Quantity		PC	1	1	1
Weight	Net Weight	lbs.	240	254	258
	Gross Weight		271	276	280
Piping Design	Height Diff between ODU and IDU	ft.	164		
	Height Diff between IDUs		49.0		
	Total Pipe Length		590		
	Max Piping Length		279		
Operation Range	Cooling	°F	23-131		
	Heating	°F	-13-78		

Note:

- Rated cooling capacity and rated heating/low temp. heating capacity are tested in the following conditions:
Cooling Operation Conditions - Indoor Air Inlet Temp: 80°F DB, 67°F WB / Outdoor Air Inlet Temp: 95°F DB
Heating Operation Conditions - Indoor Air Inlet Temp: 70°F DB / Outdoor Air Inlet Temp: 47°F DB, 43°F WB
Low Temp. Heating Operation Conditions - Indoor Air Inlet Temp: 70°F DB / Outdoor Air Inlet Temp: 17°F DB, 15°F WB
- The sound pressure level is measured in an anechoic chamber so that reflected echo should be taken into consideration in the field.

R32 CHV6 URBAN VRF



THE R32 TOP DISCHARGE CHV6 URBAN SERIES

Single chassis unit from 6 to 20 Ton.
Combinations up to 40 Ton.

Model Name			CHV6-RS072URB	CHV6-RS096URB	CHV6-RS120URB
Tonnage			6	8	10
Power Supply			AC3Ø 208/230V/60Hz		
Cooling	Capacity	kW	20.2	27	33.4
		kBtu/h	69	92	114
	EER (Ducted/Non-ducted)	(Btu/h)W	11.80/12.2	11.90/11.80	11.80/11.80
	IEER (Ducted/Non-ducted)	(Btu/h)W	19.00/21.00	19.30/22.10	18.90/21.60
Heating	Capacity	kW	21.98	29.31	36.93
		kBtu/h	75	100	126
	COP 47°F (Ducted/Non-ducted)	kW kW	3.55/3.78	3.40/3.50	3.50/3.46
SCHE (Ducted/Non-Ducted)		Btu/h/W	14.41/21.45	14.30/21.34	14.63/21.56
Ventilation	Air Flow Rate	m ³ /min	177	177	225
		CFM	6,249	6,249	7,946
	Fan Quantity	PC	1	2	2
Sound	Sound Pressure Level	dB(A)	57	59	61
Compressor	Type	-	Enhanced Vapor Injection Scroll Compressor		
	Compressor Quantity	PC	1	1	2
Refrigerant	Type	-	R32		
	Pre-Charged Amount	lbs.	16.8	21.4	27.8
Weight	Net Weight	lbs	593	705	880
Dimensions	External (HxWxD)	in.	70-55/64×37-1/64×32-31/64	70-55/64×54-23/32×32-31/64	70-55/64×54-23/32×32-31/64
	Packaging (HxWxD)	in.	77-11/64×39-3/8×34-27/32	77-11/64×57-3/32×34-27/32	77-11/64×57-3/32×34-27/32
Heat Pump Operation System	Gas Line	in.	3/4	7/8	1-1/8
	Liquid Line	in.	3/8	3/8	1/2
Heat Recovery Operation System	High Pressure Gas Line	in.	5/8	3/4	3/4
	Low Pressure Gas Line	in.	3/4	7/8	1-1/8
	High/Low Pressure Gas Line	in.	5/8	3/4	7/8
	Liquid Line	in	3/8	3/8	1/2
Max Connectable Indoor Units	Quantity	PC	128		
Piping Design	Height Difference Between IDUs and ODUs	ft.	361		
	Height Difference Between IDUs		131		
	Max Piping Length		772		
	Total Pipe Length		3609		
Operation Range	Cooling	°F	5°F DB - 131°F DB		
	Heating	°F	-22°F WB - 86°F DB		

CHV6-RS144URB	CHV6-RS168URB	CHV6-RS192URB	CHV6-RS216URB	CHV6-RS240URB
12	14	16	18	20
AC3Ø 208/230V/60Hz				
40.4	46.9	53.9	60.4	66.8
138	160	184	206	228
10.90/10.90	10.90/11.20	10.90/10.90	9.90/10.90	10.90/10.90
18.10/21.50	18.00/20.40	18.00/20.40	18.00/19.20	18.00/18.90
43.96	49.82	58.62	64.48	73.27
150	170	200	220	250
3.30/3.30	3.30/3.30	3.30/3.30	3.30/3.30	3.30/3.30
22.10/25.60	22.30/25.60	22.80/26.60	21.90/25.50	21.80/25.60
258	317	317	408	408
9,117	11,200	11,200	14,406	14,406
2	2	2	2	2
61	62	63	66	67
Enhanced Vapor Injection Scroll Compressor				
2	2	2	2	2
R32				
27.8	27.8	27.8	34.2	34.2
880	880	880	1,168	1,168
70-55/64×54-23/32×32-31/64	70-55/64×54-23/32×32-31/64	70-55/64×54-23/32×32-31/64	70-55/64×74-1/64×32-31/64	70-55/64×74-1/64×32-31/64
77-11/64×57-3/32×34-27/32	77-11/64×57-3/32×34-27/32	77-11/64×57-3/32×34-27/32	77-11/64×76-3/8×34-27/32	77-11/64×76-3/8×34-27/32
1-1/8	1-1/8	1-1/8	1-1/8	1-1/8
1/2	1/2	1/2	1/2	5/8
3/4	7/8	7/8	7/8	7/8
1-1/8	1-1/8	1-1/8	1-1/8	1-1/8
7/8	7/8	7/8	1-1/8	1-1/8
1/2	1/2	1/2	1/2	5/8
128				
361				
131				
772				
3609				
5°F DB - 131°F DB				
-22°F WB - 86°F DB				

Notes:
 1. Rated cooling capacity and rated heating capacity are tested in the following conditions: Cooling Conditions: indoor air inlet temperature: 80°F DB 66°F WB, outdoor air inlet temperature: 95°F DB, pipe length: 24.6ft, pipe height difference: 0ft. Heating Conditions: indoor air inlet temperature: 68°F DB, outdoor air inlet temperature: 45°F DB 43°F WB, pipe length: 24.6ft, pipe height difference: 0ft.
 2. The above noise values are measured in the anechoic chamber without reflected echo, therefore the impact of the reflected echo must be included at the scene. Measurement point: 1m from the service cover surface and 4.9ft from the floor level.
 3. When the connection ratio is lower than 50% or higher than 130%, please consult our local technical engineers.



Indoor Unit Feature Overview

☑ = Standard ☐ = Optional X = Incompatible

	IDU	4-WAY CASSETTE	MINI 4-WAY CASSETTE	MULTI POSITION AIR HANDLER	DUCTED CEILING	WALL MOUNTED
ACCESSORIES	DRAIN PUMP (BUILT-IN)	☑	☑	X	☑	X
	FILTER	☑	☑	☑	☑	☑
	HUMIDITY SENSOR	☑	☑	☑	☑	☑
	MOTION SENSOR	☐	☐	X	X	X
	HI-MOTION	☐	☐	☐	☐	☐
	OUTLET AIR TEMP SENSOR	☑	☑	X	X	☑
	FLOAT SWITCH	☑	☑	X	☑	X
	REFRIGERANT DETECTOR	☑	☑	☑	☑	☐
FEATURES	DRY CONTACT INPUT	☑	☑	☑	☑	☑
	DRY CONTACT OUTPUT	☑	☑	☑	☑	☑
	WINDOWS LINKAGE	☑	☑	☑	☑	☑
	FRESH AIR INTAKE	☑	☑	X	☑	X
	SLEEP MODE	☑	☑	☑	☑	☑
	QUIET MODE	☑	☑	X	☑	☑
	ECO MODE	☑	☑	☑	☑	☑
	BREEZE MODE	☑	☑	☑	X	X
	INDIVIDUAL LOUVER CONTROL	☑	☑	X	X	X
	SELF CLEANING	☑	☑	☑	☑	☑
	AUTO FAN SPEED	☑	☑	☑	☑	☑

Comfort, Health and Convenience

- Built-In R32 Refrigerant Sensor
- Refrigerant Leak Detection and Alarm Recovery function
- Built-In Humidity Sensor, temperature and humidity dual control
- Comfort Cooling function - adjustable to 3 temperature levels
- Motion Sensor - automatically adjusts whether to direct airflow towards people or not
- Support 1° adjustment, for less temperature fluctuation
- MERV 8 Filter screen accessories
- Self-Cleaning function
- Implement main sub control of master and slave machines
- Setback function
- Third party heat source linkage function

For MPAHU

- The four directions are installed (up/down/left/right), Convenience of installation
- A variety of alarm signal output: PCB output alarm signal to alarm, wired controller alarm
- Dc motor, maximum static pressure 0.8 in. WG, 6 wind speed, efficient and energy-saving
- Built-in 24v thermostat interface



GENERAL FEATURES & FUNCTIONS

4-WAY CEILING CASSETTE
4-WAY MINI CEILING CASSETTE

SLIM DUCTS LOW STATIC PRESSURE
SLIM DUCTS HIGH STATIC PRESSURE

WALL MOUNTS*
MULTI-POSITION AIR HANDLER UNIT



48-INCH DRAINAGE HEIGHT

Some CHV indoor models are equipped with a drain pump to pull condensation upward and remove water from the units with a drainage height of up to 48 inches.



SELF DIAGNOSIS

CHV indoor units use the self-diagnosis function to monitor and analyze malfunctions. Error codes are displayed on LED displays, remote controllers, or PCB boards as a general troubleshooting guide.



COMPACT SIZE

Compact indoor units can be conveniently transported and installed, even in small spaces.



REMOTE CONTROL

Indoor units can be controlled with wireless remote controller featuring an LCD display.



SILENT OPERATION

CHV units create minimal sound pressure during operation.



ADJUSTABLE LOUVER POSITION

CHV indoor units feature adjustable louvers for more precise directional air flow.



SWING LOUVER

CHV ceiling cassettes and wall mounts include louvers which swing automatically for even air distribution.



3D AIR FLOW PANEL (OPTIONAL)

The optional 3D air-flow panel, which includes an LED display and adjustable horizontal and vertical louvers, enables system control with a Cooper&Hunter wireless remote controller.



FAN SPEED

All CHV indoor units have 6 selectable fan speeds.



AUTO FAN SPEED

Fan speed rotation is automatically controlled to achieve optimum efficiency and comfort.



EASY MAINTENANCE

CHV indoor units provide convenient access to filters and other important components for easy upkeep and increased longevity.



WIDE CAPACITY RANGE

CHV indoor units come in a wide range of capacities across 5 different indoor model types.



AUTO RESTART

The automatic restart function sets the indoor units to automatically restart and resume previous settings in the event of a power outage.



LOW TEMPERATURE COOLING

The target temperature of indoor units can be set as low as 60°F.



WiFi ADAPTER (OPTIONAL)

An optional WiFi adapter can be installed to enable system control via iOS or Android smart device for up to 64 indoor units.



WIRELESS RECEIVER

Indoor units can be controlled via C&H wireless remote controller when a wireless receiver is installed. CHV wall mounts include a wireless receiver, but it is an optional accessory for other model types.



HUMIDITY SENSOR (OPTIONAL)

The optional humidity sensor allows access to more precise dehumidification control.



SMART HUMAN MOTION SENSOR

Intelligent motion sensing technology enables auto ON/OFF, auto fan, and auto temperature adjustments based on movement and occupancy of the room.



FRESH AIR INTRODUCTION

Fresh air can be directed into rooms with an optional adapter or direct connection to the air return segment of the unit.



STANDARD FILTER INCLUDED

A washable, long-life filter is included as a standard part.

*Wall Mounts do not include Built-In R32 Refrigerant Sensor.



CONVENIENT DESIGN / SUITABLE FOR HIGH CEILINGS

The 4-way Ceiling Cassette, available in 9.37 in and 8.46 in models, features a sophisticated design which fits in standard ceiling grids. CHV ceiling cassettes can be installed up to 13.78 ft high without interfering with airflow or air conditioning capabilities.

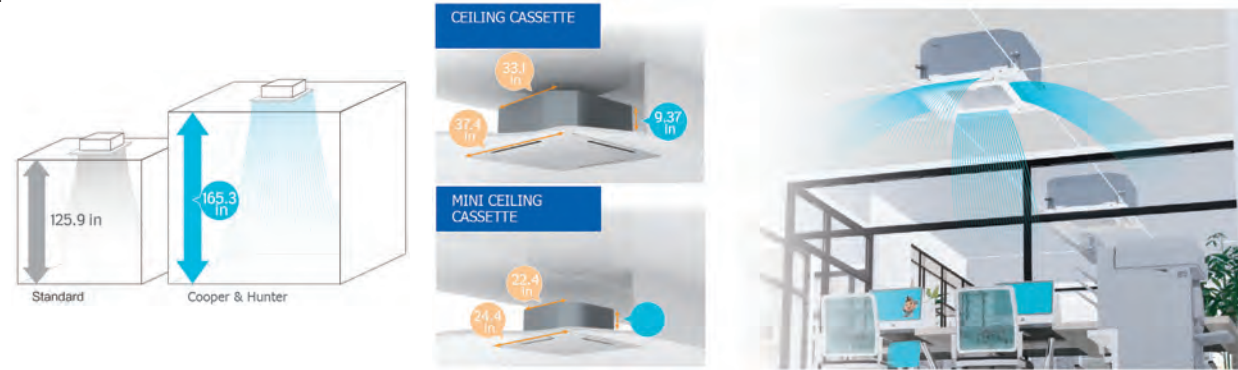

PRECISE LOUVER CONTROL

The louvers of CHV ceiling cassettes can be controlled individually with 6 angle settings and a maximum reach angle of 64°.



CEILING CASSETTE MOTION SENSOR

The smart motion sensor can be utilized for a variety of purposes. For example, it can automatically turn the unit on/off or direct the airflow towards or away from people, depending on the control settings. Additionally, in heavy-traffic times or areas, the temperature can automatically adjust to maintain a comfortable indoor climate.

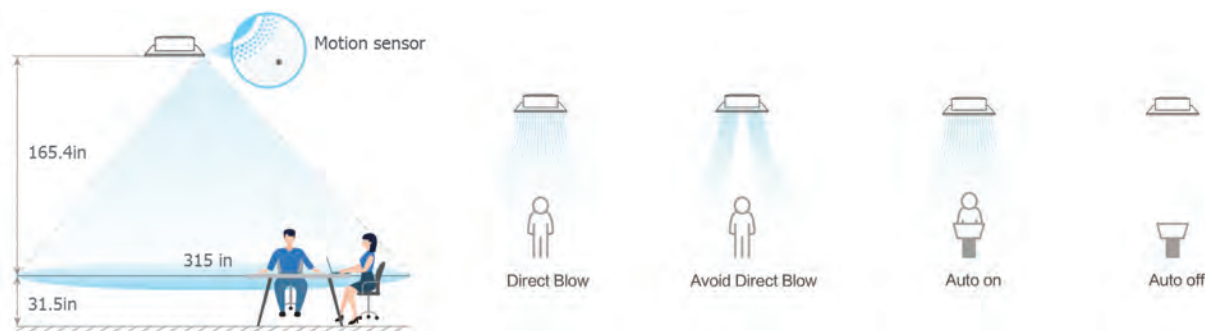

Accessories Standard Cassettes										
Wired Controllers			Wireless Controller	Central Controller	Decoration Panel	Receiver Kit	Motion Sensor	Humidity Sensor	WIFI Adapter	Fresh Air Duct Adapter
SPWT-A01	SPWT-B01	SPWT-WG01	SPRC-101	SPCC-D10	SHP-G-NK	SPWRK-T03	SPHNS-01E	SPHDS-S01E	SPHM-64M	SPFA2.64



Model Name			CHV-RS09SCC4W	CHV-RS12SCC4W	CHV-RS15SCC4W	CHV-RS19SCC4W	CHV-RS24SCC4W
Capacity	Cooling	Btu/h	9,600	12,300	15,300	19,100	24,200
	Heating	Btu/h	10,900	13,700	17,000	21,500	27,300
Input Power		W	20	30	40	50	60
Power Supply		V/Ph/Hz	208-230V / 1Ph / 60Hz				
Electrical Parameters	MCA	A	0.25	0.38	0.54	0.63	0.69
	MOP	A	15	15	15	15	15
Airflow Rate		CFM	310/353/381/424/452/529	321/381/416/452/494/600	370/402/445/490/529/670	370/416/445/490/529/670	519/558/635/674/741/953
Sound Pressure Level		dB(A)	26/26/27/28/28/30	26/27/28/29/29/32	26/27/29/29/31/33	26/28/28/30/31/34	28/29/31/32/33/36
Dimensions (H x W x D)		in.	9.69x33.06x33.06	9.69x33.06x33.06	9.69x33.06x33.06	9.69x33.06x33.06	9.69x33.06x33.06
Decoration Panel		in.	1.84x37.41x37.41				
Weight		lbs.	44.1	44.1	44.1	44.1	47.4
Connection Pipe Diameter	Liquid	in.	1/4	1/4	1/4	1/4	3/8
	Gas	in.	1/2	1/2	1/2	1/2	5/8
	Drain	in.	1 1/4	1 1/4	1 1/4	1 1/4	1 1/4

Model Name			CHV-RS30SCC4W	CHV-RS38SCC4W	CHV-RS48SCC4W	CHV-RS54SCC4W
Capacity	Cooling	Btu/h	30,700	38,200	47,800	54,600
	Heating	Btu/h	34,100	42,700	54,600	61,400
Input Power		W	70	80	130	130
Power Supply		V/Ph/Hz	208-230V / 1Ph / 60Hz			
Electrical Parameters	MCA	A	0.70	0.80	1.5	1.5
	MOP	A	15	15	15	15
Airflow Rate		CFM	540/597/646/718/787/883	724/830/918/1013/1041/1394	791/854/960/1045/1183/1306	840/904/1,020/1084/1200/1306
Sound Pressure Level		dB(A)	30/31/33/35/36/37	33/34/36/38/40/42	34/36/38/40/44/46	36/38/40/41/44/46
Dimensions (H x W x D)		in.	9.69x33.06x33.06	11.31x33.06x33.06	11.31x33.06x33.06	11.31x33.06x33.06
Decoration Panel		in.	1.84x37.41x37.41			
Weight		lbs.	51.8	57.3	57.3	57.3
Connection Pipe Diameter	Liquid	in.	3/8	3/8	3/8	3/8
	Gas	in.	5/8	5/8	5/8	5/8
	Drain	in.	1 1/4	1 1/4	1 1/4	1 1/4

Bacnet	CH-Checker	Shut-Off Box
SPBN-H160	SPHCH-64	SPRSOB-RS15

- The nominal cooling capacity and heating capacity are based on the following conditions: Cooling Operation Conditions, Indoor Air Inlet Temperature: 80°F DB, 66°F WB, Outdoor Air Inlet Temperature: 95°F DB Piping Length: 24.6ft, Piping Lift: 0ft Heating Operation Conditions, Indoor Air Inlet Temperature: 68°F DB, Outdoor Air Inlet Temperature: 44°F DB, 42°F WB
- The sound pressure level is based on the following conditions: 4.9ft beneath the unit. The above data was measured in an anechoic chamber so that the reflected sound should be taken into consideration in the field
- The actual appearance of outdoor units may differ from photos.
- Specifications are subject to change without notice.

CEILING CASSETTES



4 WAY MINI CEILING CASSETTE



Model Name		CHV-RS05MCC4W	CHV-RS07MCC4W	CHV-RS09MCC4W	CHV-RS12MCC4W	CHV-RS15MCC4W	CHV-RS17MCC4W	CHV-RS19MCC4W	
Capacity	Cooling	Btu/h	5,100	7,500	9,600	12,300	15,300	17,000	19,100
	Heating	Btu/h	6,800	8,500	11,220	14,300	17,000	19,100	21,500
Input Power	W	14	14	14	16	22	30	40	
Power Supply	V/Ph/Hz	208-230V / 1Ph / 60Hz							
Electrical Parameters	MCA	A	0.19	0.19	0.19	0.20	0.29	0.38	0.49
	MOP	A	15						
Airflow Rate	CFM	256/232/220/199	256/232/220/199	280/256/232/208	292/256/232/208	333/213/252/238	393/339/312/252	446/387/333/286	
Sound Pressure Level	dB(A)	30/29/28/26	30/29/28/26	32/30/28/26	34/32/29/26	38/36/31/28	42/39/36/31	45/42/38/34	
Dimensions (H x W x D)	in.	8.47x22.44x22.44							
Decoration Panel	in.	1.44x24.44x24.44							
Weight	lbs.	32	32	32.6	32.6	34.8	34.8	34.8	
Connection Pipe Diameter	Liquid	1/4							
	Gas	1/2							
	Drain	1 1/4							

Accessories Mini Cassettes										
Wired Controllers			Wireless Controller	Central Controller	Decoration Panel	Receiver Kit	Motion Sensor	Humidity Sensor	WIFI Adapter	Fresh Air Duct Adapter
SPWT-A01	SPWT-B01	SPWT-WG01	SPRC-101	SPCC-D10	SHPE-D-NK	SPWRK-Z01	SPHNS-MACN	SPHDS-S01E	SPHM-64M	SPFA2.64

Bacnet	CH-Checker	Shut-Off Box	<ol style="list-style-type: none"> The nominal cooling capacity and heating capacity are based on the following conditions: Cooling Operation Conditions, Indoor Air Inlet Temperature: 80°F DB, 66°F WB, Outdoor Air Inlet Temperature: 95°F DB, Piping Length: 24.6ft, Piping Lift: 0ft, Heating Operation Conditions, Indoor Air Inlet Temperature: 68°F DB, Outdoor Air Inlet Temperature: 44°F DB, 42°F WB The sound pressure level is based on the following conditions: 4.9ft beneath the unit. The above data was measured in an anechoic chamber so that the reflected sound should be taken into consideration in the field The actual appearance of outdoor units may differ from photos. Specifications are subject to change without notice.
SPBN-H160	SPHCH-64	SPRSOB-RS15	

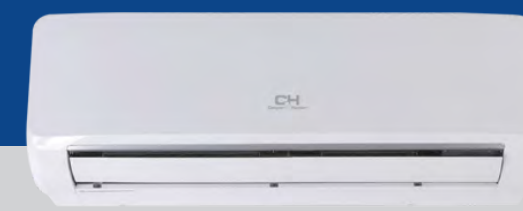

WALL MOUNTS

WALL UNITS

HIGH EFFICIENCY DC FAN MOTOR

The DC fan motor provides low-cost operation with a minimum power consumption as low as 20W, which is approximately 60% less than conventional air conditioning options.

QUIET OPERATION

Super silent DC fan motors and EEVs ensure quiet operation of C&H wall mounted units. Sleep Mode and Silent Mode can also be utilized for further noise reduction.

6 FAN SPEEDS

6 indoor fan speeds are available to meet a variety of needs.

SELF-CLEAN FUNCTION

CHV wall mounts have a Self-Clean function which dries the coil to eliminate build-up of dust, mildew, and other airborne particles.



Model Name		CHV-RS07WTU	CHV-RS09WTU	CHV-RS12WTU	CHV-RS15WTU	CHV-RS19WTU	CHV-RS24WTU	CHV-RS28WTU	
Capacity	Cooling	Btu/h	7,500	9,600	12,300	15,400	19,100	24,200	28,700
	Heating	Btu/h	8,500	11,300	13,700	17,100	21,500	27,300	28,700
Input Power	W	20	20	30	20	30	50	80	
Power Supply	V/Ph/Hz	208-230V / 1Ph / 60Hz							
Electrical Parameters	MCA	A	0.36	0.36	0.43	0.45	0.45	0.75	0.81
	MOP	A	15						
Airflow Rate	CFM	347/323/305/288/264/247	347/323/305/288/264/247	364/323/305/288/264/247	406/389/365/318/306/283	571/530/501/471/430/406	707/636/601/530/471/412	824/777/707/601/501/430	
Sound Pressure Level	dB(A)	36/35/33/32/30/28	36/35/33/32/30/28	38/35/33/32/30/28	38/37/36/32/31/29	40/38/36/35/33/31	45/42/41/38/35/31	50/48/45/41/36/33	
Dimensions (H x W x D)	in.	10.63x33.27x8	10.63x33.27x8	10.63x33.27x8	12.34x37.80x9.06	12.34x44.09x9.06	12.34x44.09x9.06	12.34x44.09x9.06	
Weight	lbs.	20.9	20.9	20.9	28.7	31.7	31.7	31.7	
Connection Pipe Diameter	Liquid	1/4							
	Gas	3/8		3/8		3/8		1/2	
	Drain	VP16							

Accessories Wall Mount Unit										
Wired Controllers			Wireless Controller	Central Controller	Motion Sensor	WIFI Adapter	Bacnet	CH-Checker	Shut-Off Box	Refrigerant Detector
SPWT-A01	SPWT-B01	SPWT-WG01	SPRC-101	SPCC-D10	SPHNS-S01E	SPHM-64M	SPBN-H160	SPHCH-64	SPRSOB-RS15	SPRD-RS01

- The nominal cooling capacity and heating capacity are based on the following conditions: The above data was measured in an anechoic chamber so that reflected sound should be taken into consideration in the field. Cooling Operation Conditions Indoor Air Inlet Temperature: 80°F DB, 66°F WB Outdoor Air Inlet Temperature: 95°F DB
- Heating Operation Conditions Indoor Air Inlet Temperature: 68°F DB, Outdoor Air Inlet Temperature: 44°F DB, 42°F WB Piping Length: 2.6ft. Piping Lift: 0ft. The sound pressure level is based on following conditions: 2.6ft.(0.8m) below the unit and 3.3ft.(1m) in front of the unit. The above noise values are measured under the condition of air supply.
- The actual appearance of outdoor units may differ from photos.
- Specifications are subject to change without notice.



ADJUSTABLE STATIC PRESSURE AND IMPROVED AIR QUALITY

The static pressure of the slim duct fan can be adjusted to suit various noise and air flow needs. Fresh air supply and filters ensure improved air quality.

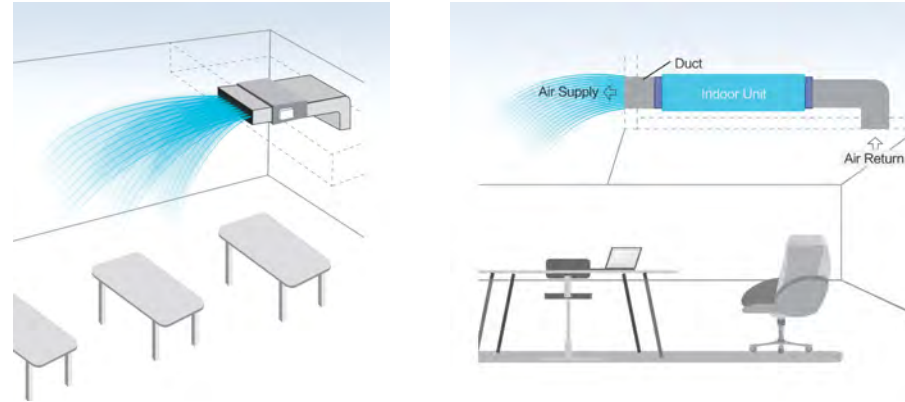

3D AIR FLOW PANEL (OPTIONAL)

The optional 3D air-flow panel, which includes an LED display and adjustable horizontal and vertical louvers, enables system control with a Cooper&Hunter wireless remote controller and the capability for more precise directional air flow.

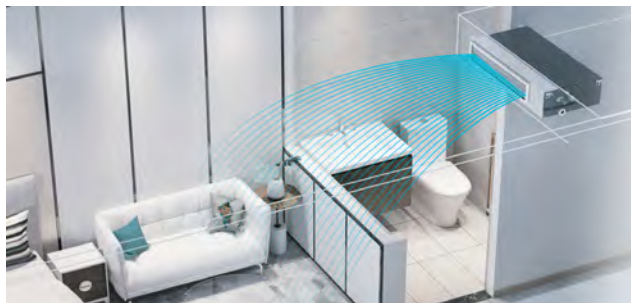

TEMPERATURE PRECISION

CHV slim ducted units include 3 temperature sensors to prevent overcooling or overheating of the room. The sensors send real-time signals to the unit for more accurate temperature supply.

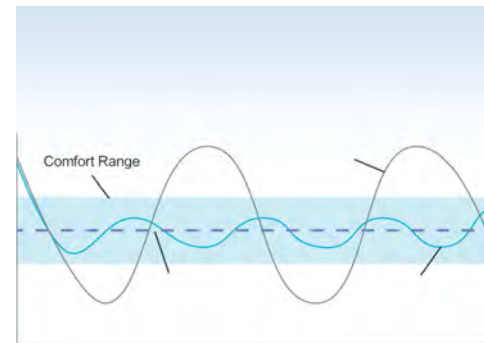

DRAIN PUMP

CHV low static pressure slim ducts include a standard drain pump and a maximum drain height of 47 inches. Internal and external drain pumps are optional accessories available for high static pressure slim ducts.

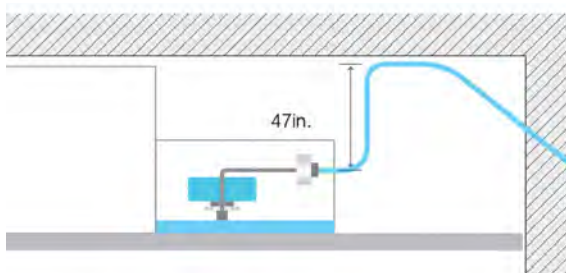

DEVICE CONNECTION OPTIONS

Third party building management systems and sensors can be connected to the indoor unit via dry contacts. Devices such as hotel room key card, window contact and fire alarm can be connected at the same time.

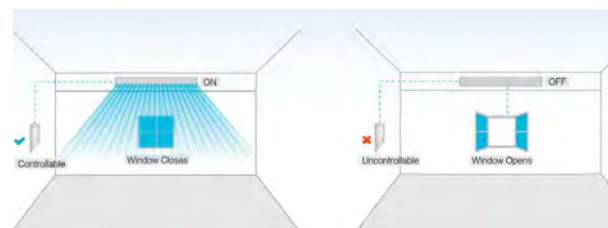

Model Name			CHV-RS05SDLSP	CHV-RS07SDLSP	CHV-RS09SDLSP	CHV-RS12SDLSP	CHV-RS15SDLSP	CHV-RS19SDLSP	CHV-RS24SDLSP
Capacity	Cooling	Btu/h	5,800	7,500	9,600	12,300	15,300	19,100	24,200
	Heating	Btu/h	6,500	8,500	11,300	13,600	17,100	21,500	27,300
Input Power		W	30	30	50	50	60	60	90
Power Supply		V/Ph/Hz	208-230V / 1Ph / 60Hz						
Electrical Parameters	MCA	A	0.50	0.50	0.67	0.67	0.78	0.78	1.17
	MOP	A	15						
Airflow Rate		CFM	247/230/215/201/184/170	247/230/215/201/184/170	318/286/257/237/208/184	318/286/257/237/208/184	424/381/332/286/240/194	477/441/396/353/311/272	636/569/505/434/370/307
Sound Pressure Level		dB(A)	28/27/26/24/23/21	28/27/26/24/23/21	35/32/32/30/26/23	35/32/32/30/26/23	35/32/32/30/26/23	35/32/30/28/25/23	38/36/35/33/31/24
Static Pressure Range		in. WG	0.04 (0.04 - 0.12-0.20)						
Dimensions (H x W x D)		in.	7.56x27.56x17.52	7.56x27.56x17.52	7.56x27.56x17.52	7.56x27.56x17.52	7.56x35.83x17.52	7.56x46.45x17.52	7.56x46.45x17.52
Weight		lbs.	35.3	35.3	37.5	37.5	44.1	52.9	52.9
Connection Pipe Diameter	Liquid		1/4	1/4	1/4	1/4	1/4	1/4	3/8
	Gas	in.	1/2	1/2	1/2	1/2	1/2	5/8	5/8
	Drain		VP25						

Accessories Low Static Pressure Ducted Unit											
Wired Controllers			Wireless Controller	Central Controller	Receiver Kit	Motion Sensor	Humidity Sensor	WiFi Adapter	Bacnet	CH-Checker	Shut-Off Box
SPWT-A01	SPWT-B01	SPWT-WG01	SPRC-101	SPCC-D10	SPWRK-V02	SPHNS-S01E	SPHDS-S01E	SPHM-64M	SPBN-H160	SPHCH-64	SPRSOB-RS15

SLIM DUCTS

HIGH STATIC PRESSURE



AIR HANDLER UNITS

MULTI POSITION AHU

Model Name			CHV-RS07SDHSP	CHV-RS09SDHSP	CHV-RS12SDHSP	CHV-RS15SDHSP	CHV-RS19SDHSP	CHV-RS24SDHSP
Capacity	Cooling	Btu/h	7,500	9,600	12,300	15,400	19,100	24,200
	Heating	Btu/h	8,500	10,900	13,700	17,100	21,600	27,400
Input Power		W	40	40	55	55	55	82
Power Supply		V/Ph/Hz	208-230V / 1Ph / 60Hz					
Electrical Parameters	MCA	A	0.45	0.45	0.74	0.74	0.74	0.94
	MOP	A	15					
Airflow Rate		CFM	318/283/240/ 222/205/187	318/283/240/ 222/205/187	424/388/353/ 318/283/254	424/388/353/ 318/283/254	512/459/406/ 371/335/307	671/600/530/ 459/388/335
Sound Pressure Level		dB(A)	30/27/23/21/20/19	30/27/23/21/20/19	35/33/32/28/26/24	35/33/32/28/26/24	33/30/27/25/23/22	36/34/31/28/24/22
Static Pressure Range		in. WG	0.12/0.16/0.20/0.24/0.28/0.32/0.36/0.40/0.44/0.48/0.52/0.56/0.60					
Dimensions (H x W x D)		in.	10.63x28.55x28.34	10.63x28.55x28.34	10.63x28.55x28.34	10.63x28.55x28.34	10.63x38.55x28.34	10.63x28.55x28.34
Weight		lbs.	53	53	53	53	66	66
Connection Pipe Diameter	Liquid		1/4					
	Gas	in.	1/2				5/8	
	Drain		VP25					

Model Name			CHV-RS30SDHSP	CHV-RS38SDHSP	CHV-RS48SDHSP	CHV-RS54SDHSP
Capacity	Cooling	Btu/h	30,800	38,000	48,000	54,500
	Heating	Btu/h	34,200	42,500	54,500	61,500
Input Power		W	100	132	180	223
Power Supply		V/Ph/Hz	208-230V / 1Ph / 60Hz			
Electrical Parameters	MCA	A	0.89	1.16	1.51	2.55
	MOP	A	15			
Airflow Rate		CFM	883/812/742/ 671/600/530	989/883/812/ 742/671/600	1254/1148/1042/ 936/830/724	1377/1254/1095/ 936/830/770
Sound Pressure Level		dB(A)	34/32/30/28/25/22	37/35/31/29/26/23	38/36/34/31/29/26	41/38/35/33/30/27
Static Pressure Range		in. WG	0.20/0.24/0.28/0.32/0.36/0.40/0.44/0.48/0.52/0.56/0.60/0.64/0.68/0.72/0.76/0.80			
Dimensions (H x W x D)		in.	11.8x46.27x31.5	11.8x46.27x31.5	11.8x58.08x31.5	11.8x58.08x31.5
Weight		lbs.	92	92	125	125
Connection Pipe Diameter	Liquid		3/8			
	Gas	in.	5/8			
	Drain		VP25			

Accessories High Static Pressure Ducted Unit									
Wired Controllers			Wireless Controller	Central Controller	Receiver Kit	Motion Sensor	Humidity Sensor	WIFI Adapter	Drain Pump
SPWT-A01	SPWT-B01	SPWT-WG01	SPRC-101	SPCC-D10	SPWRK-V02	SPHNS-S01E	SPHDS-S01E	SPHM-64M	SPIDP-DHP07/24-27/54-76/96

Drain Pump	Bacnet	CH-Checker	Shut-Off Box	
SPEDP-DHP07/54	SPBN-H160	SPHCH-64	SPRSOB-RS15	
<ol style="list-style-type: none"> The nominal cooling capacity is the combined capacity of the Cooper&Hunter standard split system. Cooling Operation Conditions Indoor Air Inlet Temperature: 80°F DB, 66°F WB, Outdoor Air Inlet Temperature: 95°F DB, Heating Operation Conditions Indoor Air Inlet Temperature: 68°F DB, Outdoor Air Inlet Temperature: 44°F DB, 42°F WB, Piping Length: 24.6ft, Piping Lift: 0ft The sound pressure level is based on following conditions: 4.9ft Beneath the Unit, With Discharge Duct(6.5ft.) and Return Duct(3.3ft.). Voltage of the power source for the indoor fan motor is 208V. The above data was measured in an anechoic chamber so that reflected sound should be taken into consideration in the field. The data for external pressure *1)indicates Standard Pressure Setting values when a filter is not used. The actual appearance of outdoor units may differ from photos. Specifications are subject to change without notice. 				

KEY FEATURES

- Multi positioning installation is able to fit in different type of projects and room structures.
- 100% copper pipe
- Low noise DC Fan Motor
- Optional electric heater
- Built-in R32 refrigerant sensor.
- A variety of alarm signal outputs; PCB output alarm signal to alarm, Wired controller alarm.
- The unit can be connected to a third-party heat source.
- Built-in 24v thermostat interface.
- Convenient cleaning and replacement, filter is removed without tools



Model Name			CHV-RS09MPAHU	CHV-RS12MPAHU	CHV-RS18MPAHU	CHV-RS24MPAHU	CHV-RS36MPAHU	CHV-RS48MPAHU	CHV-RS60MPAHU
Capacity	Cooling	Btu/h	9,000	12,000	18,000	24,000	36,000	48,000	60,000
	Heating	Btu/h	10,000	14,000	20,000	27,000	40,000	54,000	66,000
Power Supply		V/Ph/Hz	208-230V/ 1Ph / 60Hz						
Electrical Parameters	MCA	A	2.35	2.35	5.94			7.81	7.81
	MOP	A	15	15	6.48			15	15
Airflow Rate		CFM	375	375	611/580/550/ 518/488/457	611/580/550/ 518/488/457	1139/1091/1013/ 928/849/770	1299	1954
Sound Pressure Level		dB(A)	39	39	41/41/38/37/36/34	41/41/38/37/36/34	54/52/50/49/47/45	50	58
Dimensions (H x W x D)		in.	36.03X17.72X21.06	36.03X17.72X21.06	46x19.63x21.63	46x19.63x21.63	46x19.63x21.63	53.94x22.05x24.17	53.94x22.05x24.17
Weight		lbs.	114.6	114.6	140.8	140.8	147.4	206.8	206.8
Connection Pipe Diameter	Liquid		1/4	1/4	3/8	3/8	3/8	5/8	5/8
	Gas	in.	1/2	1/2	5/8	5/8	5/8	3/8	3/8
	Drain		NPT3/4	NPT3/4	1 1/4 (VP16)			NPT3/4	NPT3/4

Accessories MAHU							
Wired Controllers			Wireless Controller	Central Controller	Receiver Kit	Motion Sensor	WIFI Adapter
SPWT-A01	SPWT-B01	SPWT-WG01	SPRC-101	SPCC-D10	SPWRK-V02	SPHNS-S01E	SPHM-64M

Drain Pump	Bacnet	CH-Checker	Shut-Off Box	
SPEDP-DHP07/54	SPBN-H160	SPHCH-64	SPRSOB-RS15	
<ol style="list-style-type: none"> The nominal cooling capacity is the combined capacity of the Cooper&Hunter standard split system. Cooling Operation Conditions Indoor Air Inlet Temperature: 80°F DB, 66°F WB, Outdoor Air Inlet Temperature: 95°F DB, Heating Operation Conditions Indoor Air Inlet Temperature: 68°F DB, Outdoor Air Inlet Temperature: 44°F DB, 42°F WB, Piping Length: 24.6ft, Piping Lift: 0ft The sound pressure level is based on following conditions: 4.9ft Beneath the Unit, With Discharge Duct(6.5ft.)and Return Duct(3.3ft.). Voltage of the power source for the indoor fan motor is 208V. The above data was measured in an anechoic chamber so that reflected sound should be taken into consideration in the field. The data for external pressure *1)indicates Standard Pressure Setting values when a filter is not used. The actual appearance of outdoor units may differ from photos. Specifications are subject to change without notice. 				



SPWT-A01



SPWT-B01



SPWT-WG01



SPRC-101



Wired Controllers

- Cool/Heat/Auto/Dry/Fan
- Air filter cleaning reminder
- Fan speed control
- 1°F temperature setting
- 3D airflow customization
- 72-hour timer
- Backlight control
- Up to 16 indoor units can be connected
- Error code display
- Built-in temperature sensor
- Dehumidification
- Check function
- One touch test run
- Self cleaning
- Multiple speeds
- Swinging louvers

- Cool/Heat/Auto/Dry/Fan
- Fan speed control
- 24-hour timer
- Check function
- Error code history display
- PCB inspection indoor/outdoor
- Backlight control
- Wireless control available
- Breeze mode
- Eco mode (energy saving mode)
- Sleep mode
- 3D airflow customization
- Dehumidification
- Performance monitoring
- Air filter cleaning reminder
- Automatic test run
- Self-diagnosis function
- Built-in temperature sensor
- Individual louver control
- Quiet mode / silent mode
- Self-cleaning

- Cool/Heat/Auto/Dry/Fan
- Fan speed control
- 24-hour/7-Day timer
- Check function
- Error code history display
- PCB inspection indoor/outdoor
- Backlight control
- Wireless control available
- Breeze mode
- Eco mode (energy saving mode)
- Sleep mode
- 3D airflow customization
- Dehumidification
- Performance monitoring
- Air filter cleaning reminder
- Automatic test run
- Self-diagnosis function
- Built-in temperature sensor
- Individual louver control
- Quiet mode / silent mode
- Self-cleaning

Wireless Controller

- Performance monitoring
- Automatic test run
- Fan speed control
- Backlight control
- Individual louver control
- Sleep mode
- 3D airflow customization
- Fan speed control
- 24-hour timer
- Self-diagnosis function
- Built-in temperature sensor
- Breeze mode
- ECO (energy saving mode)
- Sleep mode
- Self-cleaning function

Wireless Receiver Kit

- SPWRK-T03
- SPWRK-Z01
- SPWRK-V02
- SPWRK-X01H



Remote Receiver

Central Controller

- 10 in. touch screen with 1280x800 resolution
- Max of 160 IDU connections
- Max 64 connectable IDU Groups
- VRF and ATW System control
- Weekly / Holiday schedule
- Remote control with web access
- Rotation operation control for equipment room
- Password setting
- External I/O ports
- Multi language

SPWRK-X01H



SPWRK-T03



SPWRK-Z01



SPWRK-V02



CHV Adapter

SPHM-64M



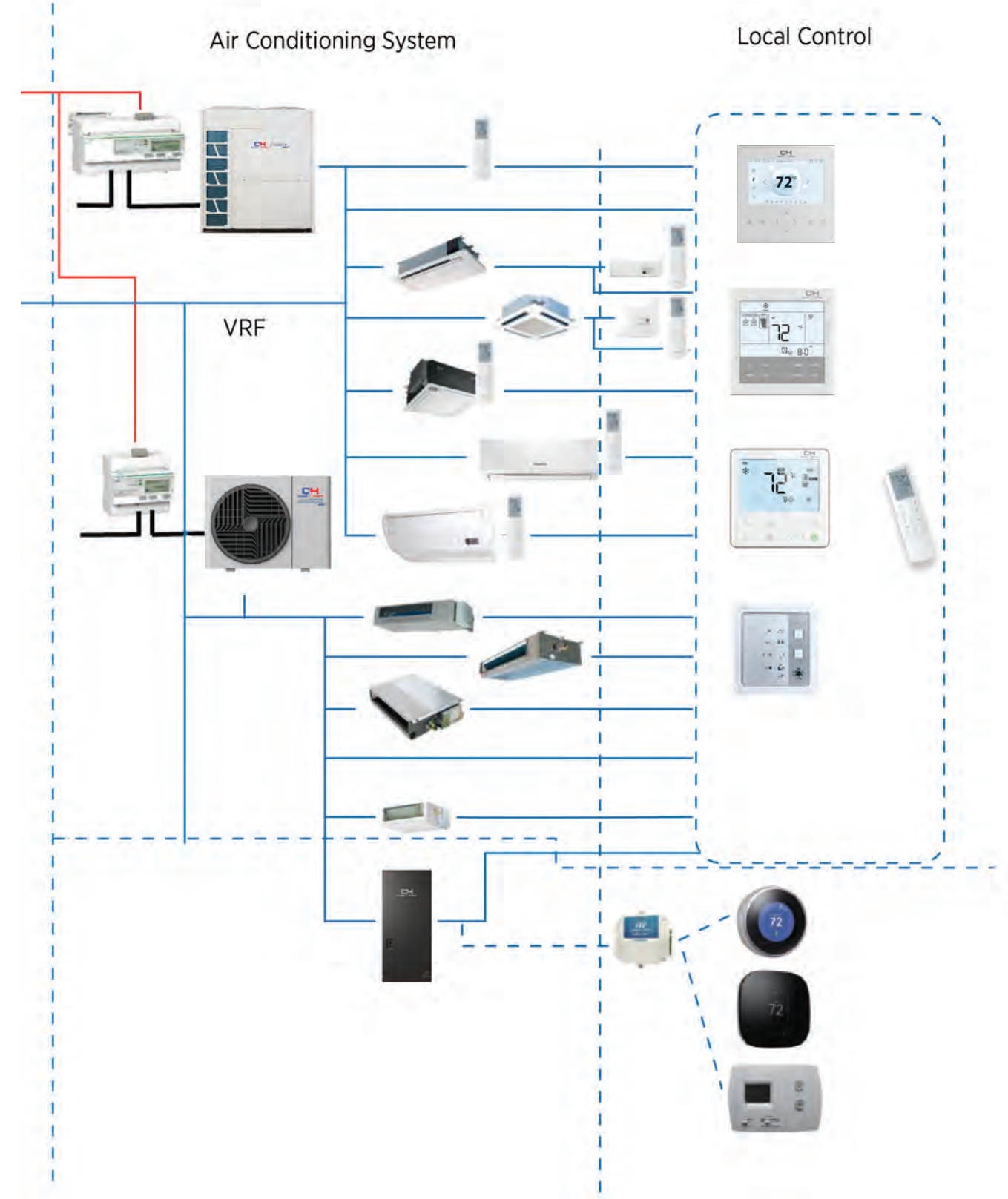
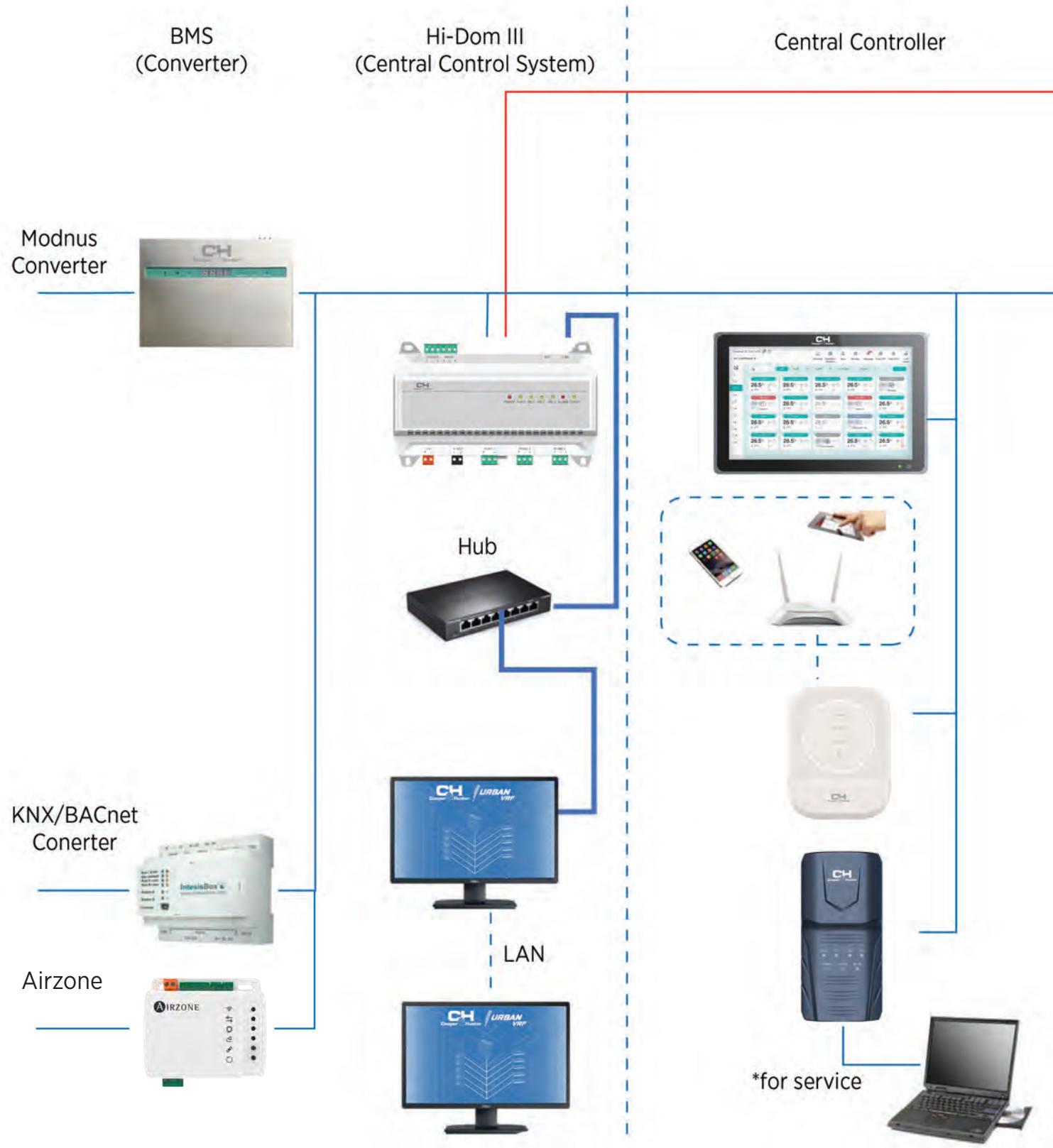



Shut-Off Box

- Capacity: 10HP
- Max. 17 IDUs for 1 port
- Be closed automatically when power off
- 6000pls/33/64 in. valve for gas pipe and 3000pls/15/64 in. valve for liquid pipe

Model		SPRSOB-RS15	
Application Scenarios		Two Pipe Refrigerant Shut-off Box	
Power Supply		208-230V - 60Hz	
Power Consumption	W	9.2	
Number of Ports for IDU		1	
Max Total Capacity of all connected IDUs		kBTU/h	<96
Single Refrigerant Shut-off Box in same refrigerant system	Max number of connected IDUs per box	-	13
Multiple Refrigerant Shut-off Boxes in same refrigerant system	Max number of connected IDUs per box	-	8
Indoor Unit	Gas Pipe	in.	5/8
	Liquid Pipe	in.	3/8
Dimensions	HxWxD	in.	8.26x 14.96x 8.42
Net Weight	lbs.	18.3	
Refrigerant	type	R32	
Running Current	A	0.14	
Recommended Fuse/Breaker size	A	10	
Max Fuse size	A	15	



Refrigerant Detector

Model		SPRD-RS01	
Detectable Refrigerant		R32	
Power Supply		IDU or Power Adapter (Output Current ≥1A)	
Rated Voltage	V	DC 12±10%	
Detected Threshold Value	ppm	5000	
Operating Temperature Range	°F	-4-140°F	
Operating Humidity Range	RH	5-95% (non-condensing)	
Average Power Consumption	mA	100	
Dimensions (WxDxH)	in.	3.23x3.23x.87	
Net Weight	oz.	2.68	
Connecting Cable Specifications	AWG	19	
Max Cable Length Between IDU and Refrigerant Detector	ft.	32.80	



Refrigerant Sensor

- Built-in installation
- Infrared NDIR detection
- Powered by 12±10% VDC from IU or reserved dedicated power supply port
- Alarm value 5000ppm
- Dry contact reserved
- Design life ≥10 years

Item		SPRS-RS02	
Detectable Refrigerant		R32	
Power Supply		Indoor Unit	
Rated Voltage	V	DC 12±10%	
Detected Threshold Value	ppm	5000	
Operating Temperature Range	°F	-4-185°F	
Operating Humidity Range	RH	0-95% (non-condensing)	
Average Power Consumption	mA	45	
Dimensions (WxDxH)	in.	2.38x0.74x2.44 in	
Net Weight	oz.	2.5	

VRF SELECTION SOFTWARE

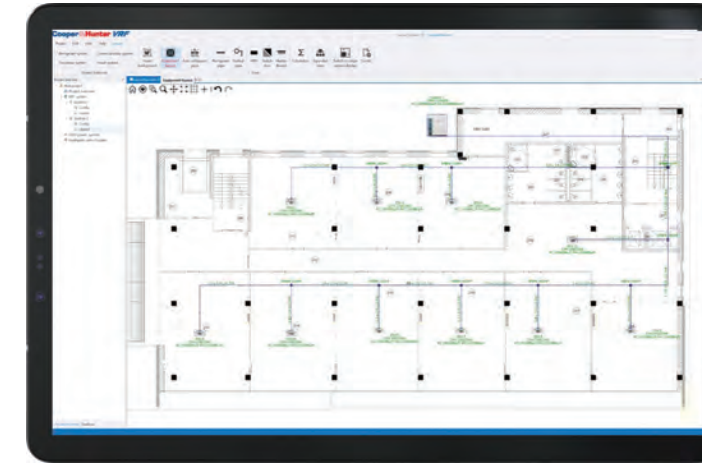

C&H Selection Software can be used to create projects of any complexity, mixing and matching Cooper&Hunter's VRF equipment to create the perfect personalized system. Unit compatibility can be conveniently calculated on any Windows PC device.

C&H Selection Software does not only ensure system compatibility and provide easy access to reference important project details, but can also automatically generate system suggestions, connection pipe lengths, and detailed project reports. Users are also able to upload blueprints and project plans into the program to configure their project directly on the digital copy and avoid drawing by hand.

CH-CHECKER

CH-Checker is a plug and play service tool, with which service engineers can access the VRF system to monitor operation status and get data pertaining to each of the units. It is very convenient for system communication and maintenance, and features cloud-based management with easy to access operation status remotely.

- Compact size allows high portability and space saving.
- Capable to slot in a 32G memory card for data collection and storage.
- Memory card and card reader are standard with CH-Checker.
- Multiple choices of power supply types. It can be powered by the standard adapter (DC 5V), computer or power bank.
- Support OTA update, ensuring the software is always up to date.



An Intelligent Tool for Intelligent Service.

- Conventional connection type. The simplest and most reliable way to connect the CH-Checker to your computer is directly through USB.
- Internet connection type. Connect to a stable Wi-Fi signal to achieve operation data and status monitoring anytime and anywhere.
- Hotspot connection type. Connect to a temporary hotspot signal from the smartphone, allowing the CH-Checker to remotely monitor the operation data when there is no stable Wi-Fi signal on site.
- SD card storage type. CH-Checker equipped with SD card can be connected to the air conditioning system all the time, so that all the operation data can be stored in the card for later analysis.

CH

Cooper & Hunter



CHV 6 CATALOG 2026

URBAN
VRF
S E R I E S

COOPER&HUNTER



With more than 25 years of experience in air conditioning and ventilation, Cooper&Hunter has grown into a leading HVAC market player. The brand is dedicated to technological innovation and consumer-driven product development, generating HVAC equipment that adheres to the highest quality standards, providing reliable, energy-efficient, and cost-effective air conditioning solutions.

While products under the Cooper&Hunter brand are distributed in more than 55 countries worldwide, the brand's growth within the US market has been rapid. Cooper&Hunter stands out from big-name brands by providing quality support to customers and technicians alike, with their in-house technical support team offering troubleshooting and warranty support Monday through Friday from 9am to 5pm in 5 different languages (including English, Spanish, Mandarin, Russian, and Ukrainian).

KEY FEATURES & ADVANTAGES OF CHV6 URBAN & MINI URBAN 3-16

RELIABILITY	4-7
EFFICIENCY	8-11
COMFORT	12-13
VERSATILITY	14-16

OUTDOOR UNITS 17

CHV6 URBAN	18-27
CHV6 MINI URBAN	31-32

INDOOR UNITS 33

GENERAL FEATURES & FUNCTIONS	33
CEILING CASSETTES	34-37
FLOOR CEILING	38
SLIM DUCTS	39-42
WALL MOUNTS	43
AHU & CONNECTION KIT	44-45

ACCESSORIES 46-50

VRF SELECTION SOFTWARE

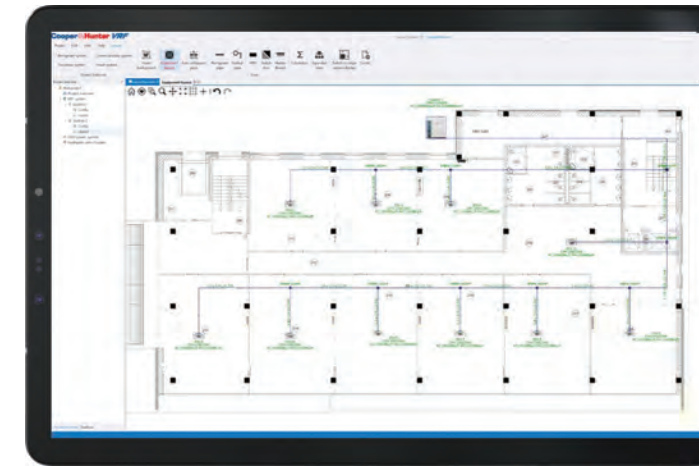

Contractors and technicians can now configure and save their Cooper&Hunter VRF systems and projects on our convenient web portal. C&H Selection Software can be used to create projects of any complexity, mixing and matching Cooper&Hunter's VRF equipment to create the perfect personalized system. Unit compatibility can be conveniently calculated on any iOS or Windows PC device.

C&H Selection Software does not only ensure system compatibility and provide easy access to reference important project details, but can also automatically generate system suggestions, connection pipe lengths, and detailed project reports. Users are also able to upload blueprints and project plans into the program to configure their project directly on the digital copy and avoid drawing by hand.

CH-CHECKER

CH-Checker is a plug and play service tool, with which service engineers can access the VRF system to monitor operation status and get data pertaining to each of the units. It is very convenient for system communication and maintenance, and features cloud-based management with easy to access operation status remotely.

- Compact size allows high portability and space saving.
- Capable to slot in a 32G memory card for data collection and storage.
- Memory card and card reader are standard with CH-Checker.
- Multiple choices of power supply types. It can be powered by the standard adapter (DC 5V), computer or power bank.
- Support OTA update, ensuring the software is always up to date.

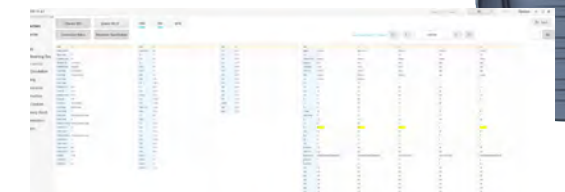

An Intelligent Tool for Intelligent Service.

- Conventional connection type. The simplest and most reliable way to connect the CH-Checker to your computer is directly through USB.
- Internet connection type. Connect to a stable Wi-Fi signal to achieve operation data and status monitoring anytime and anywhere.
- Hotspot connection type. Connect to a temporary hotspot signal from the smartphone, allowing the CH-Checker to remotely monitor the operation data when there is no stable Wi-Fi signal on site.
- SD card storage type. CH-Checker equipped with SD card can be connected to the air conditioning system all the time, so that all the operation data can be stored in the card for later analysis.

/// OIL CYCLE

The lifetime and performance of a compressor relies heavily on its oil lubrication.

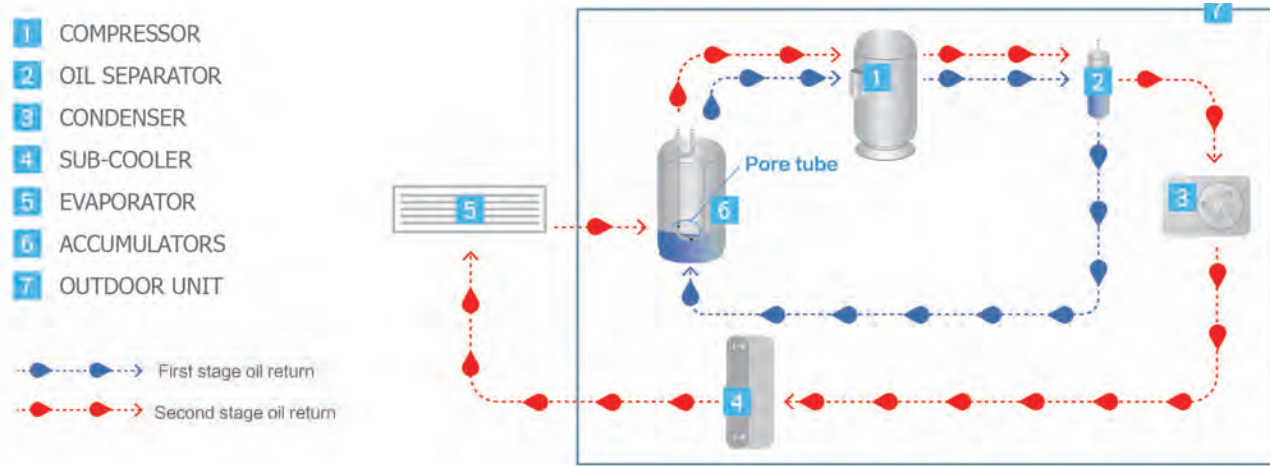

/// OIL SEPARATION

Cooper&Hunter CHV6 utilizes the latest technology for efficient oil separation with up to 99% accuracy. The first stage of oil separation takes place in the compressor, while the second stage is managed by a high-capacity centrifugal oil separator.



/// NO OIL BALANCE TUBES NEEDED FOR MODULAR INSTALLATIONS

When there are two or more outdoor units in one refrigerant cycle, the oil should be balanced among all of the compressors. Optimal oil balance is achieved by integrating porous tube technology into the accumulator, where an oil storage tank releases the oil to the compressor as needed to prevent temperature fluctuations and changes in pressure.



/// IMPROVED OIL RETENTION

The built-in oil cap reduces oil loss on start-up by 50% compared to conventional compressors. Efficient oil retention prevents failure of the compressor bearings by maintaining proper lubrication of the internal rotary components.

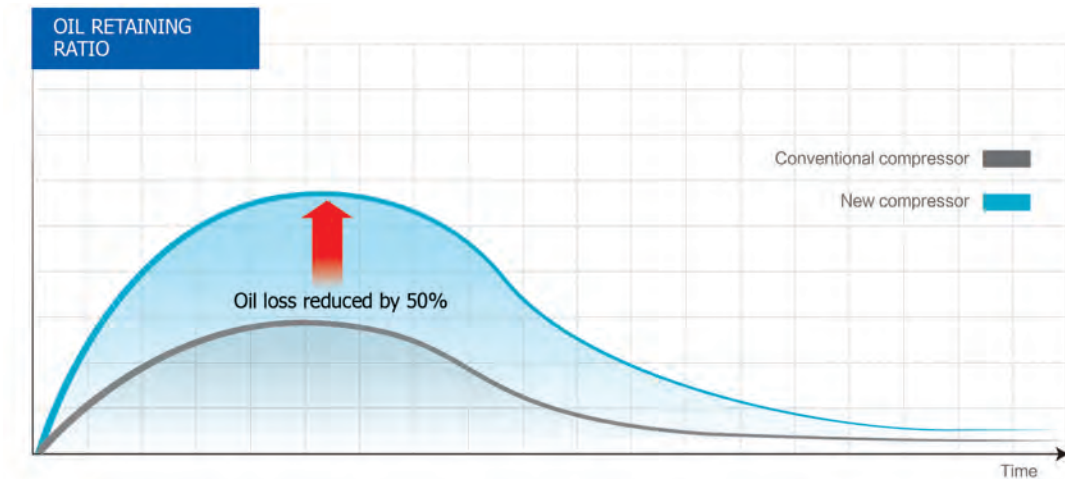

/// BACK-UP PROTECTION

Dual-compressor CHV6 systems provide the most reliable climate control. If one compressor fails, the second will operate in boost mode to ensure continued heating and cooling operation.

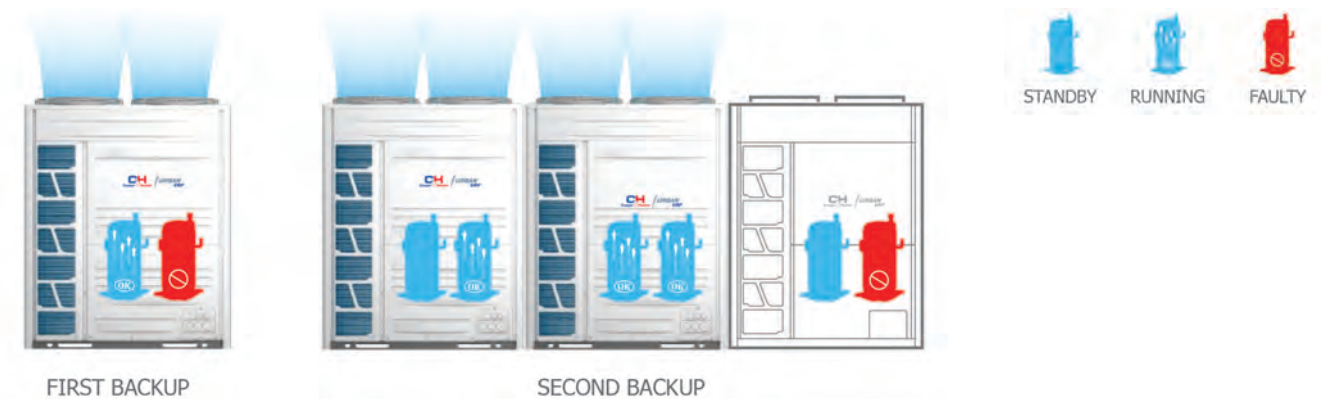

/// INTELLECTUAL ROTARY WORK

To prevent overuse of any particular unit in a modular system, the number of operating hours is maintained across all units by rotating their priority in use.

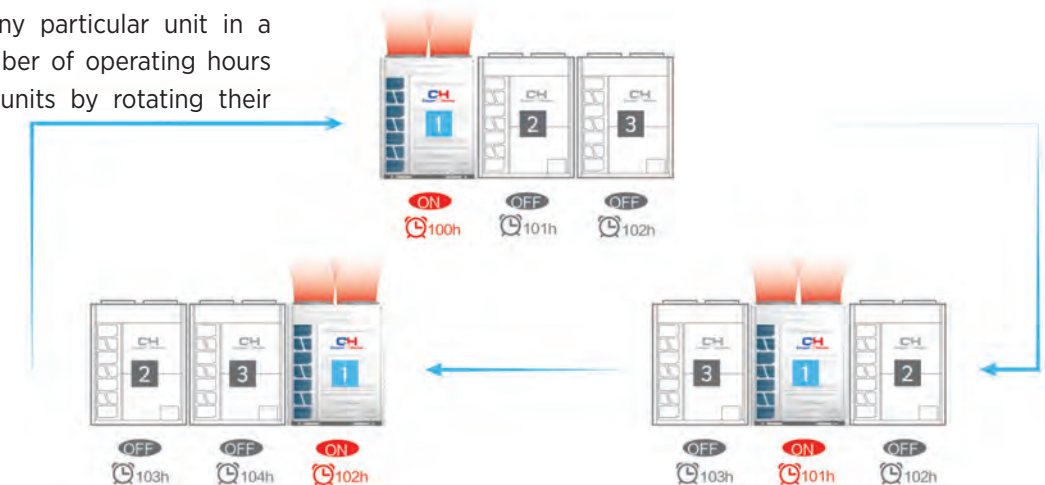

/// SELF-PROTECTION

Built-in algorithms, powered by a variety of sensors, take protective actions to prevent overheating, electrical issues, compressor malfunctions, and changes in pressures.

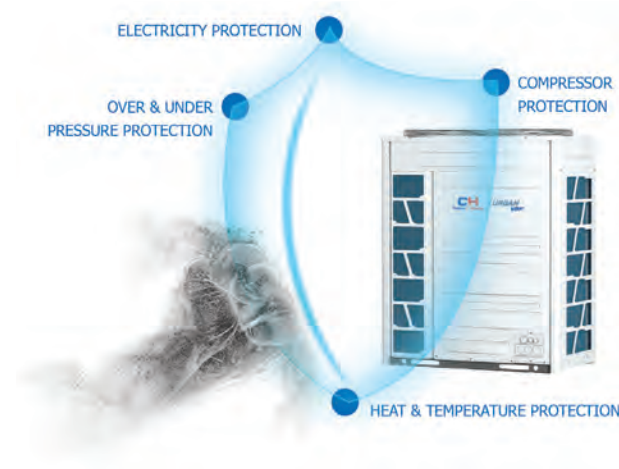

/// SAFETY AND PROTECTION

Cooper&Hunter's CHV6 systems comply with international standards and certifications by adhering to strict protective measures for fire resistance, electrical insulation, and proper grounding to prevent risk of danger.



/// ELECTRICITY AND MAGNETISM PRECAUTIONS

Electromagnetic protection is a high priority for CHV6 equipment, which is often located on the rooftops of tall buildings. Cooper&Hunter's CHV 6 URBAN equipment has gone through testing in internationally qualified laboratories for quality checks in various conditions, including sudden high voltage of 4000V.



/// WEATHERPROOF / SAFE FOR TRANSPORT

Cooper&Hunter's CHV6 URBAN equipment has forgone testing under a variety of extreme temperature conditions to ensure functionality and reliability in any weather.

Special laboratory simulators have been used to test conditions of the unit during shipping and transport by water, air, and land.



/// MAINTENANCE ZONING

In the event of a unit failure, the faulty system can be isolated for replacement or maintenance while the other units continue to operate. This allows continuous climate control, even during the troubleshooting or repair process.

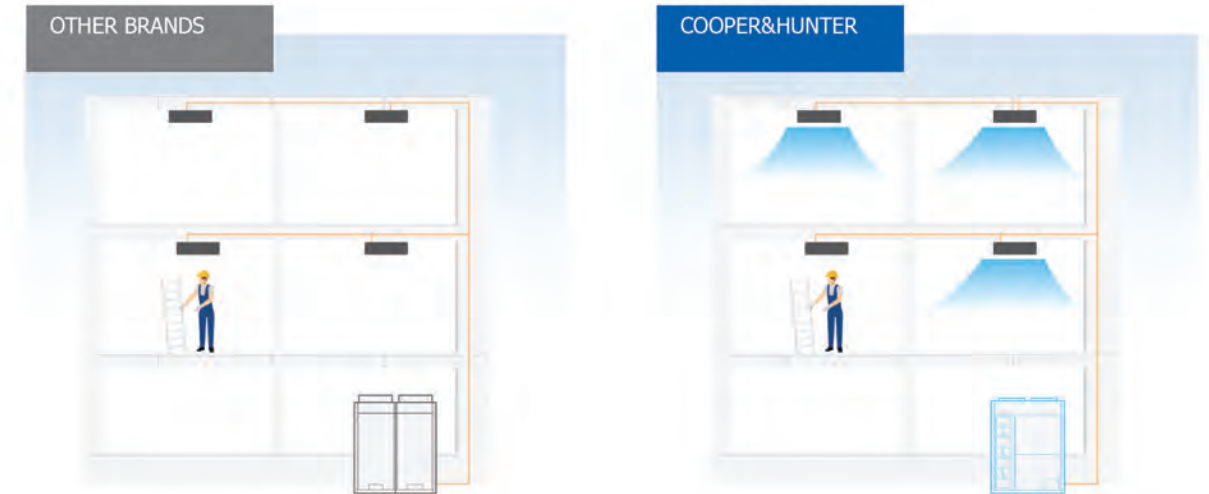

/// CONDENSATE LEAKAGE PROTECTION

Even in the event of clogged drainpipes or a drain pump malfunction, Cooper&Hunter's slim ducted units are equipped with a built-in float switch to prevent overflow. An error code will be displayed when the condensate reaches a certain level and the unit will turn off automatically if the condensate exceeds the float switch level.



NEW COMPRESSOR VAPOR TECHNOLOGY

Cooper&Hunter's CHV6 systems are equipped with scroll compressors. Vapor injection technology increases heating performance and energy saving by up to 25%.

- 1 A new air suction design offers improved compressor efficiency under fast rotating speed conditions and improved compressor stability under heavy working load.
- 2 The overpressure relief valve improves efficiency by reducing compression loss, especially in medium and low production conditions.
- 3 The highly efficient drive frame design reduces leakage loss and friction loss.
- 4 A specialized exhaust system minimizes oil loss in the compressor.
- 5 Vapor injection technology increases heating performance and energy saving.
- 6 The high efficiency DC motor operates within a range of 27 speeds to save energy.
- 7 The oil balance pipe ensures reliability of the unit.
- 8 The oil separator keeps the oil in the compressor to increase longevity of the unit.
- 9 The use of PVE oil ensures high reliability and longevity.



ENERGY USE

When refrigerant gas is compressed, it passes through an asymmetric volute and patented exhaust valve to reduce energy loss.

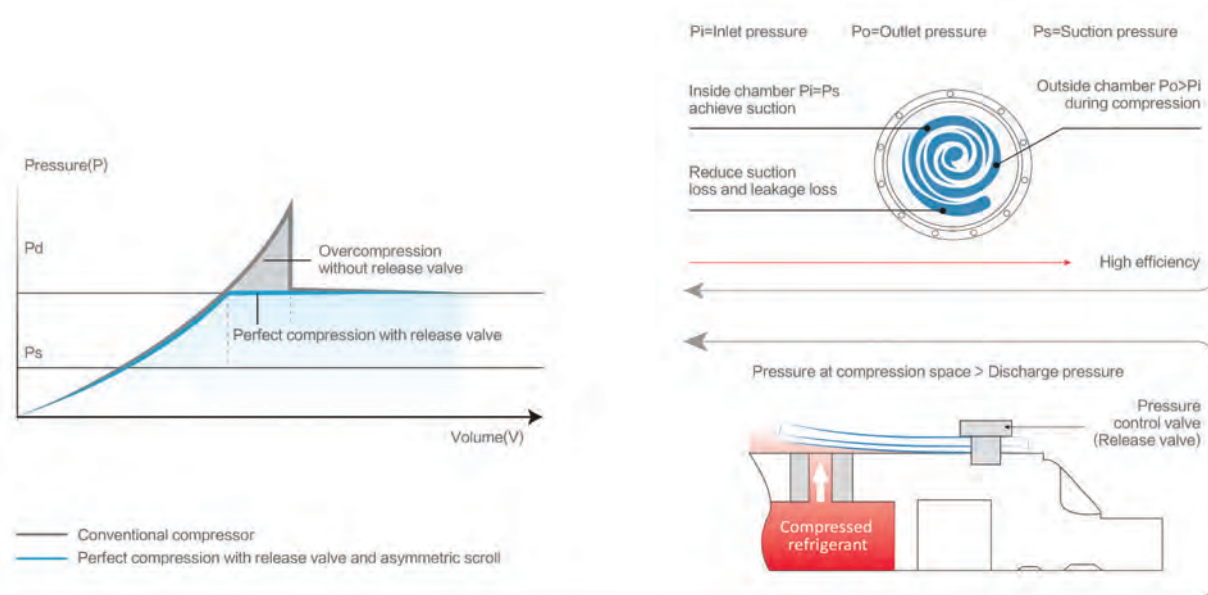

CORRUGATED FINS

Improved heat exchange efficiency and durability are provided by a new fin design, which allows a larger number of fins to be placed within the exchanger, increasing the surface area by 22%. Compared to conventional brands, the Cooper&Hunter heat exchanger is 40% more resistant to frost and the range of operation of the heat exchanger for heating between defrosts is increased by 50%.

FEATURES AND BENEFITS

Air Flow Resistance	Decreased 20%	↓
Total Heat Transfer Area	Improved 21.4%	↑
Heating Capacity Without Frost Test Condition 44°F DB / 42°F WB)	Improved 1-3%	↑
Heating Capacity With Frost Test Condition 80°F DB / 62°F WB)	Improved 8-12%	↑
Frost Resistance	Improved 40%	↑

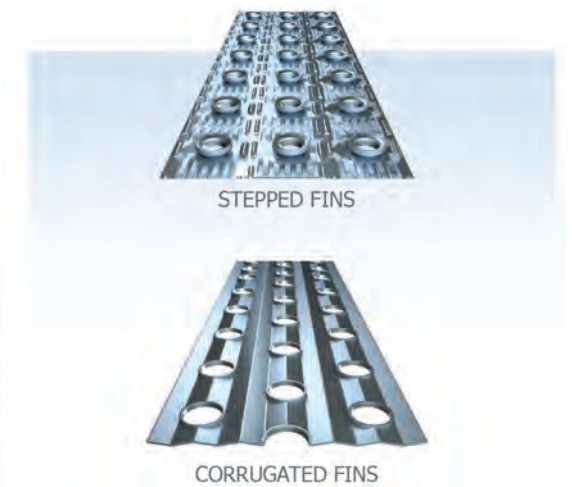

SUBCOOLING TECHNOLOGY

The Cooper&Hunter outdoor heat exchanger is designed for optimum efficiency. The first stage of subcooling can reduce the temperature by 54.5°F while the second stage can reach up to 80.6°F for effective subcooling.

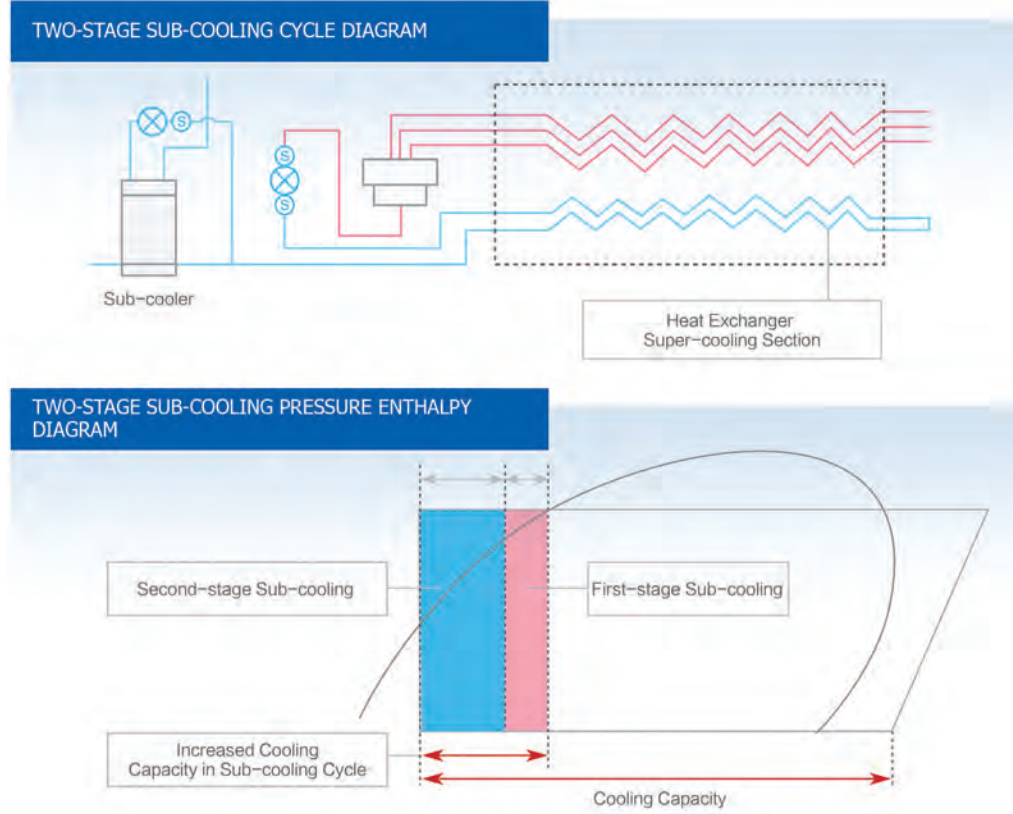

- Increases cooling capacity of the refrigerant
- Reduces resistance of refrigerant flow in pipelines
- Increases sub-cooling degree and electronic expansion valve control accuracy
- Increases sub-cooling degree, increasing the length of refrigerant pipe

REFRIGERANT TEMPERATURE CONTROL

1. The evaporating temperature can be adjusted between 35.6°F and 60.8°F, which is the widest range in the market.
2. Fast cooling depends on a lower evaporating temperature.
3. Cold draft prevention is based on higher evaporating temperatures.
4. Energy can be saved by improving seasonal efficiency.

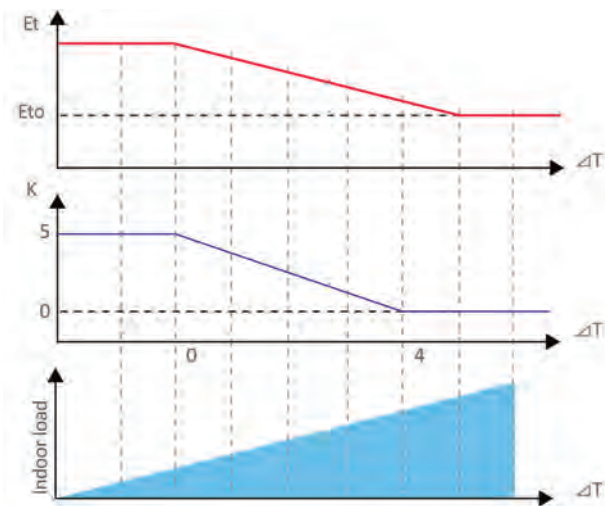

Evaporation temperature (E_t) control can be adjusted according to the difference between the room temperature (T_{in}) and the set temperature (T_{set}).

$$E_t = E_{to} + K$$

$$\Delta T = T_{in} - T_{set}$$

E_{tn} = Evaporating temperature

E_{to} = initial value of the evaporating temperature (can be adjusted by setting the outdoor unit)

K = can be automatically adjusted according to the difference between room temperature and set temperature ΔT .

AERODYNAMIC AXIAL FAN

When converting input power into wasted noise energy, the aerodynamic design of Cooper&Hunter's fan blades reduces energy loss while improving flow performance and static pressure. Enhanced efficiency and reduced noise level can also be attributed to the combination of the axial fan with a brushless DC fan motor.

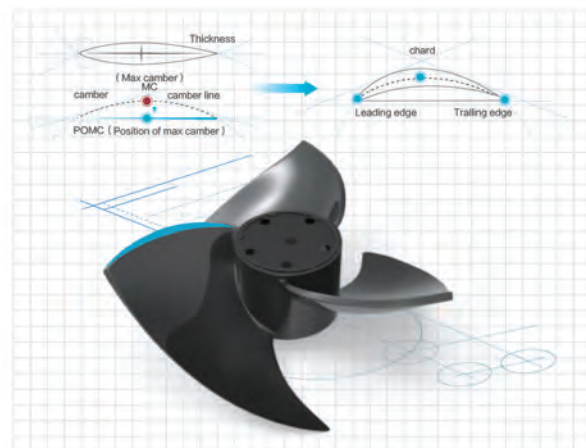

BALANCED POWER DEMAND

When the CHV6 system is in peak power demand, it automatically balances between maintaining comfort and saving energy while meeting daily power needs.

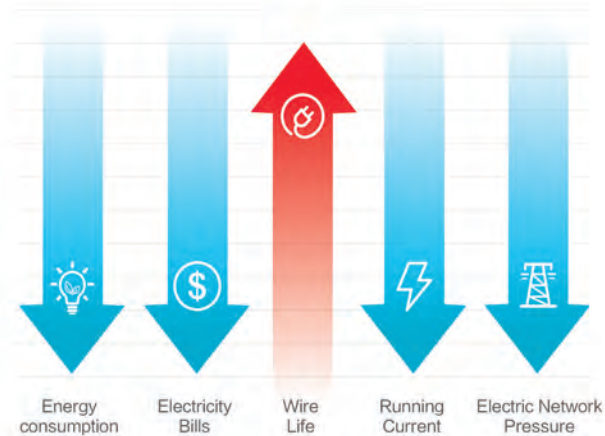

DEPENDABLE DEFROST & ANTI-FROST STRUCTURE

When low temperatures and humidity combine, water vapor in the air can accumulate and solidify as frost in the outdoor unit. For conventional units, frost accumulation on the heat exchanger can cause system malfunction or failure, but Cooper&Hunter's intelligent Defrost determines the optimal time to liquify and remove the frost, saving unnecessary energy loss associated with traditional defrost methods, and maintaining indoor comfort.

To prevent excess frost in the outdoor unit, the heat exchanger circuit extends to the bottom of the unit. This ensures that the frost does not solidify as it reaches the condensate drain and, therefore, allows smooth drainage flow. The extended heat exchanger also results in a longer interval between defrosting periods.

C&H DEFROST

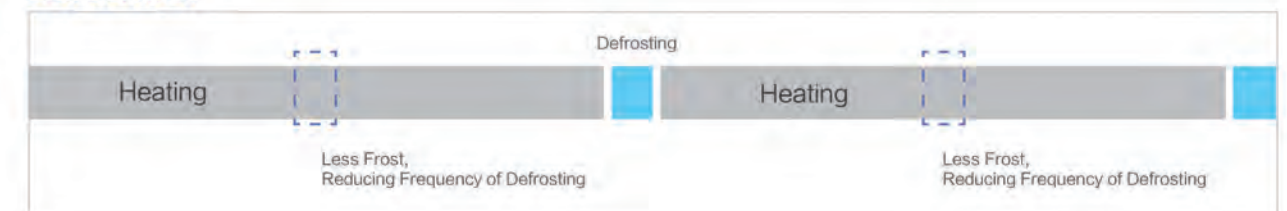

CONVENTIONAL DEFROST



TEMPERATURE ACCURACY

Cooper&Hunter CHV6 systems utilize a return air temperature sensor in combination with a temperature sensor on the remote control to accurately determine the room temperature and provide temperature stability within the 1°F range.

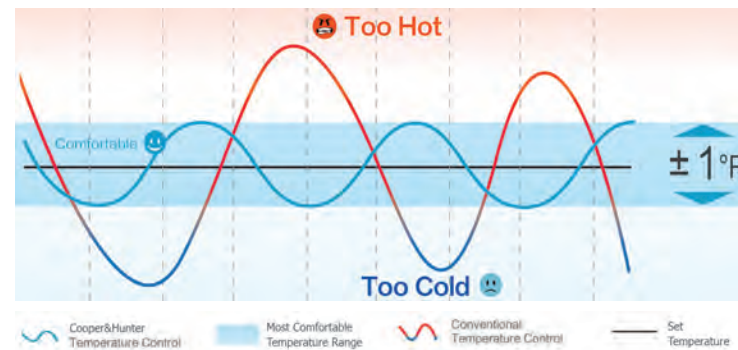

2,000 STEP EVAPORATOR EEV

A 1°F range of accuracy is achieved with a high precision 2,000-step Electronic Expansion valve (EEV) to control the flow of refrigerant based on real-time room temperature feedback from temperature sensors on controllers and indoor units. The EEV ensures accurate flow adjustment according to the actual indoor unit load.



QUIET INDOOR UNITS & NIGHT MODE FOR OUTDOOR UNITS

With a noise level as low as 19 dB(A), Cooper&Hunter's CHV indoor units offer a suitably silent solution for libraries, hospitals, and auditoriums, which often require noise levels below 25 dB(A). To reduce noise from the outdoor unit at night, Night Mode can be set on the outdoor unit PCB to reduce noise by up to 15 dB(A) for 8-10 hours every night. Advanced technology allows the user to specify the noise reduction value and the maximum operating frequency of fans and compressors during these hours.



VIP MODE

VIP mode allows for important zones or rooms to be prioritized for comfort as quickly as possible. This feature is particularly convenient in locations like hotels, where it is important to provide the best comfort solutions for residential suites.

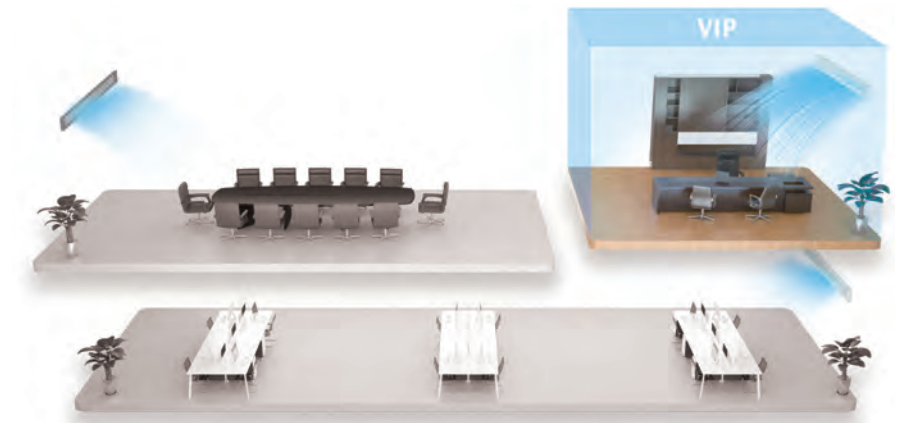

DEHUMIDIFICATION

Cooper&Hunter's CHV6 systems offer dependable cooling and heating as well as powerful dehumidification, which inhibits the growth of bacteria and provides a more comfortable indoor environment. The humidity sensor is located inside of the indoor unit to measure and control humidity with optimum precision.

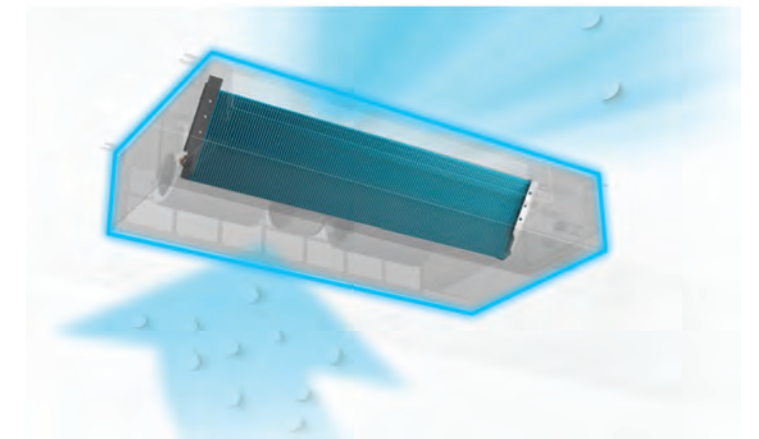

90-SECOND START-UP

Even in extremely low temperatures, Cooper&Hunter's CHV6 systems provide a quick heating solution, taking only 90 seconds to reach 100% heating performance.

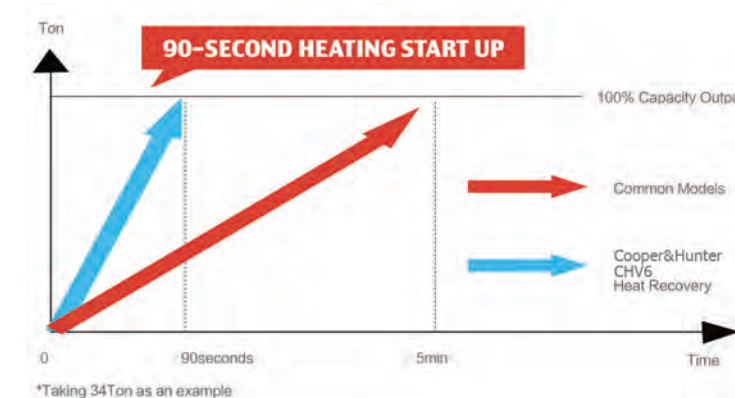

/// AUTOMATIC ADDRESSING

Up to 64 indoor units can be connected to one CHV6 outdoor unit. To eliminate the tedious task of manually addressing each of the indoor units, C&H systems utilize automatic addressing technology which addresses the indoor units by default. This can be useful for trouble-shooting scenarios when only one or few indoor units are faulty.

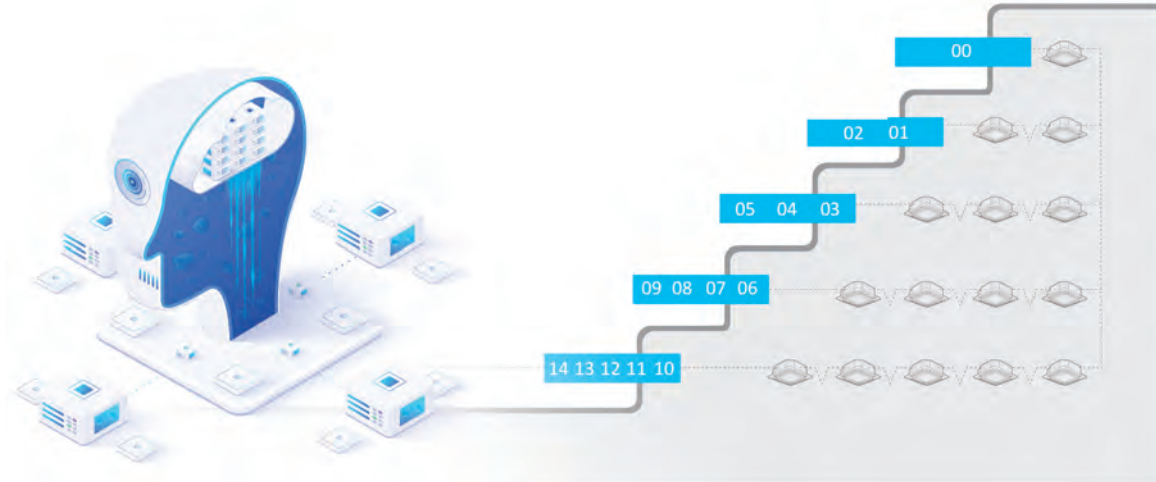

/// SAFE & CONVENIENT SYSTEM OPERATION

CHV6 outdoor units are equipped with a service window at the top of the junction box guard for easy access to the 7-segment LED display, DIP switches, and other control buttons. Using the service window for parameter checks and maintenance reduces chances of electrical shock by keeping the high-voltage components safely behind the compartment cover.



/// COMPACT & LIGHTWEIGHT

CHV6 units are compact in size and relatively lightweight. The 16 Ton chassis, which is the largest capacity per CHV6 unit, fits into a standard elevator space for transport, offering a convenient and economical solution for existing refurbishment projects as well as new installations.



/// COMMUNICATION ERROR ALERT

Cross-wiring, one of the most common mistakes made when installing A/C systems, can cause a variety of errors or system malfunction. The CHV6 condensers feature simplified wiring ports equipped with technology that will display warnings when the wires are connected incorrectly.

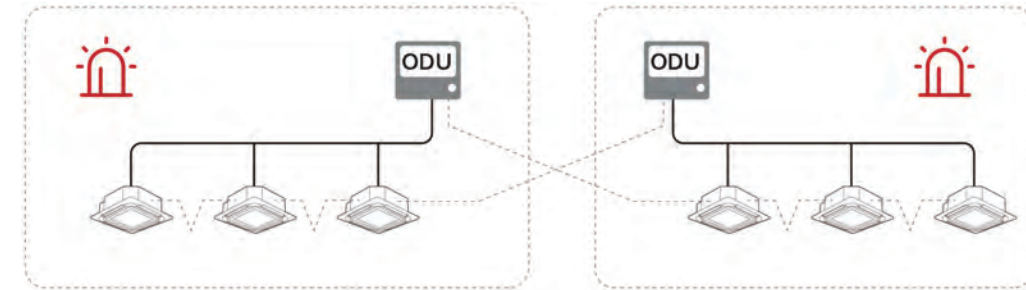

/// AUTO RESTART

In the event of a power outage, Cooper&Hunter CHV6 systems can be programmed to restart automatically, either by restoring to previous settings or with a full system restart to default settings. The auto restart function is most convenient in rooms where people are not usually present, such as hardware rooms, server rooms, etc.

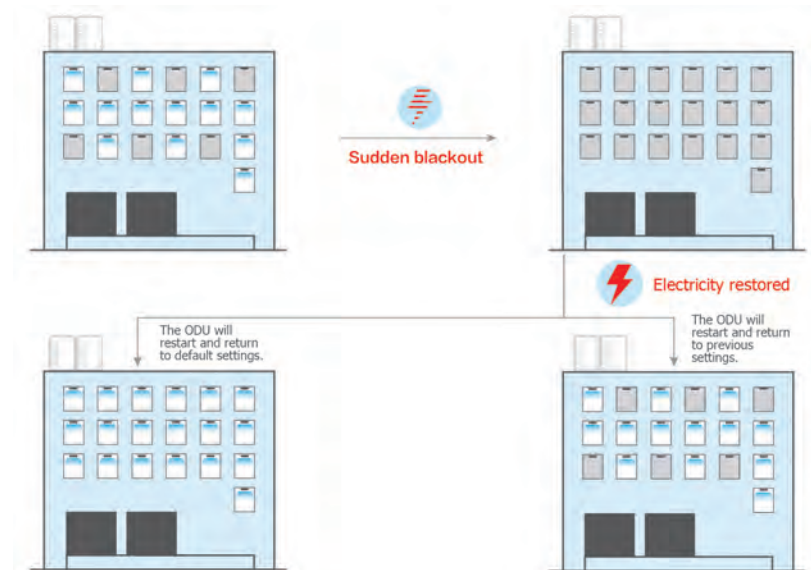

/// OUTDOOR UNIT LED

CHV6 outdoor units include a 7-segment LED which displays error codes and can be utilized when checking refrigerant, pressures, compressor frequency, alarm codes, and more. The LED conveniently simplifies operation and maintenance.



/// ELECTRICAL & MECHANICAL SEPARATION

CHV6 outdoor units are intelligently designed with separated electrical and mechanical compartments for more organized service and maintenance. Electrical and electronic parts are positioned above the compressors and accumulator to comply with the practical law of the center of gravity, reducing chances of tip-over accidents and unnecessary vibration during operation. This design also helps to maintain a stable level of heat in the electrical box and maximize airflow.

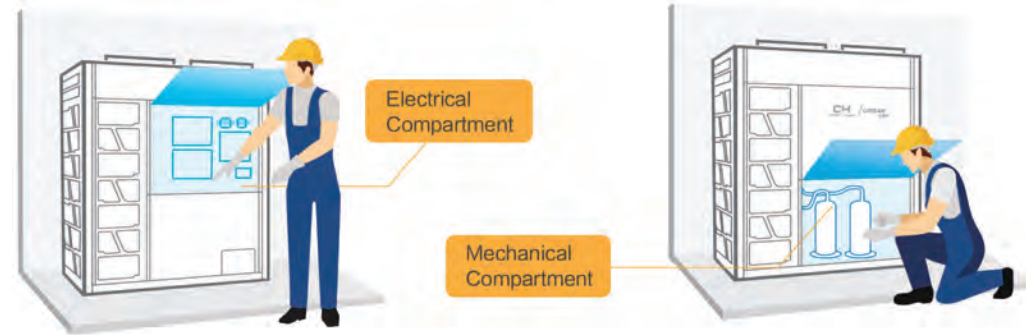

/// INTELLIGENT SYSTEM MONITORING

Cooper&Hunter offers an optional service tool for system monitoring, which greatly simplifies maintenance and troubleshooting for large systems. Indoor and outdoor units can be connected for real-time readings and monitoring of various parameters throughout the overall system.

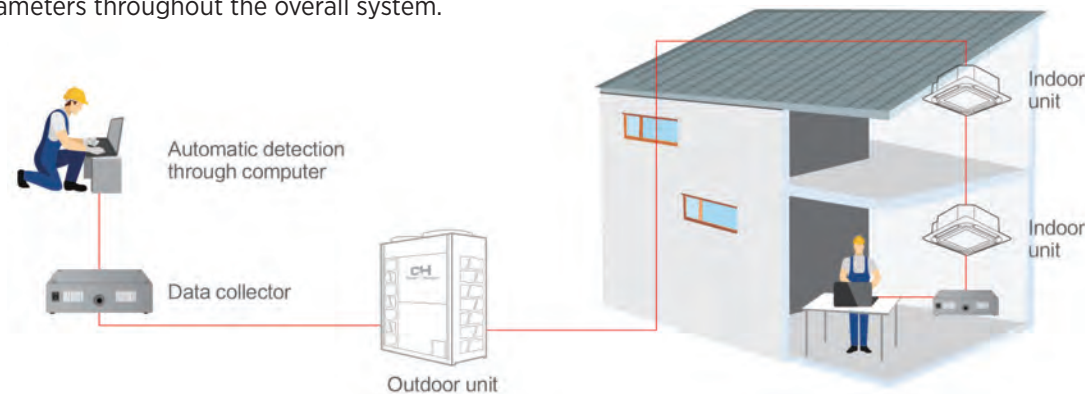

/// CONVENIENT TEST RUN

When an installation is complete, it is important for the installer to test the A/C system and verify that it is in proper working condition. For testing convenience, there is a quick test run function which can be initiated at either the indoor or the outdoor unit, so the whole system will start simultaneously.

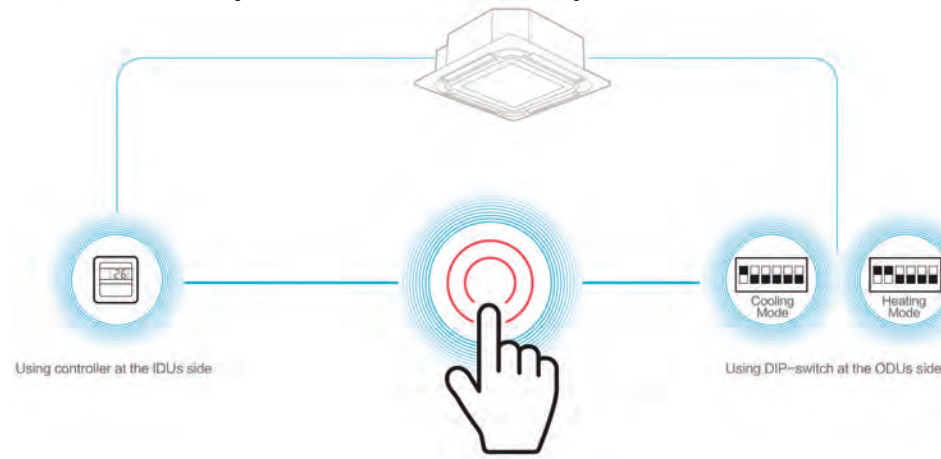

/// CHV6 INTRODUCES THE FIRST HEAT RECOVERY SYSTEM FROM COOPER&HUNTER IN THE US MARKET.

CHV6 Urban heat recovery systems, which require 3 refrigerant pipes, are able to provide simultaneous cooling and heating throughout a building or can be adapted into heat pumps with only 2 refrigerant pipes.

CHV6 Mini Urban systems offer a heat pump solution for slightly smaller applications.



/// CHV6 URBAN /// CHV6 MINI URBAN

- CHV6 URBAN 208-230V
- CHV6 URBAN 460V
- CHV6 HYPER HEAT 208-230V
- CHV6 HYPER HEAT 460V
- CHV6 MINI URBAN

ADVANCED HEAT SINK DESIGN

CHV6 Urban series utilizes built-in heat sinks to efficiently dissipate heat from the outdoor PCB, inverter module, and electrical box, improving the electrical reliability of the system.

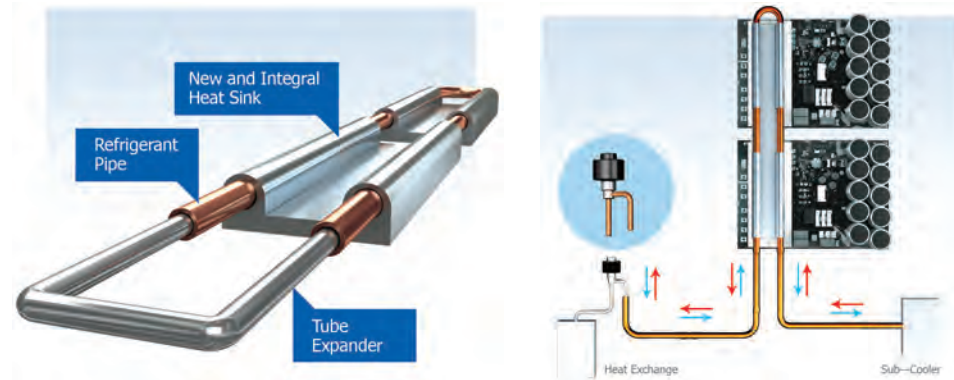

SEQUENTIAL DEFROST

In the event that a CHV6 modular system begins to freeze up, the URBAN series will defrost and heat at the same time to prevent any uncomfortable temperature fluctuations during the defrosting process. The system will automatically shift the defrost priority between the multiple outdoor units to ensure that they are all evenly utilized.

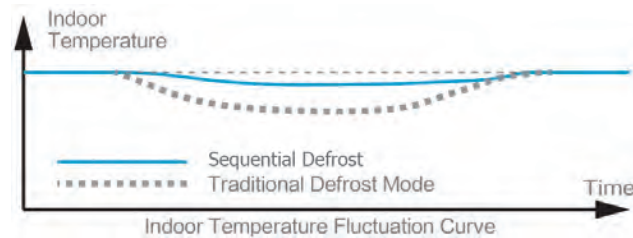

3,000-STEP OUTDOOR EEV

The 3,000-step outdoor EEV allows more precise refrigerant flow to the system.

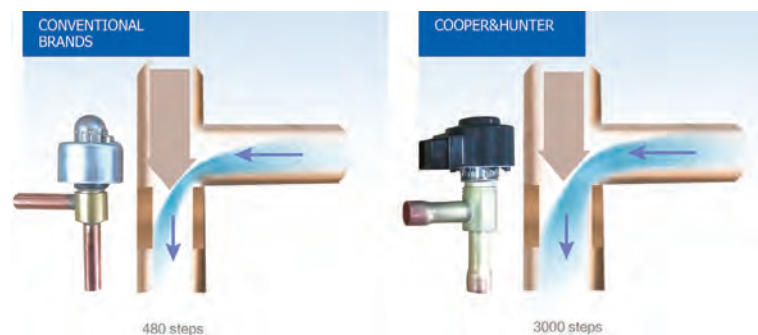

FLEXIBLE INSTALLATION PARAMETERS

Installation for Cooper&Hunter CHV6 Urban systems is highly flexible with a maximum pipe length of 3,281 ft and a maximum height difference between indoor and outdoor units of 295 ft.

- Maximum length of a single pipe: 623 ft (190m)
- Total length of pipes: 3,281 ft (1,000m)
- Maximum height difference of indoor units: 49 ft (15m) (Can be extended to 98 ft (30m) in some cases)
- Maximum height difference between indoor and outdoor units:
 - When the outdoor unit is higher: 164 ft (50m) (Can be extended to 295 ft (90m) in some cases)
 - When the indoor unit is higher: 131 ft (40m) (Can be extended to 295 ft (90m) in some cases)
- Maximum length from the first branch pipe to the farthest indoor unit: 295 ft (90m)
- Maximum pipe length between outdoor units: 33 ft (10m)

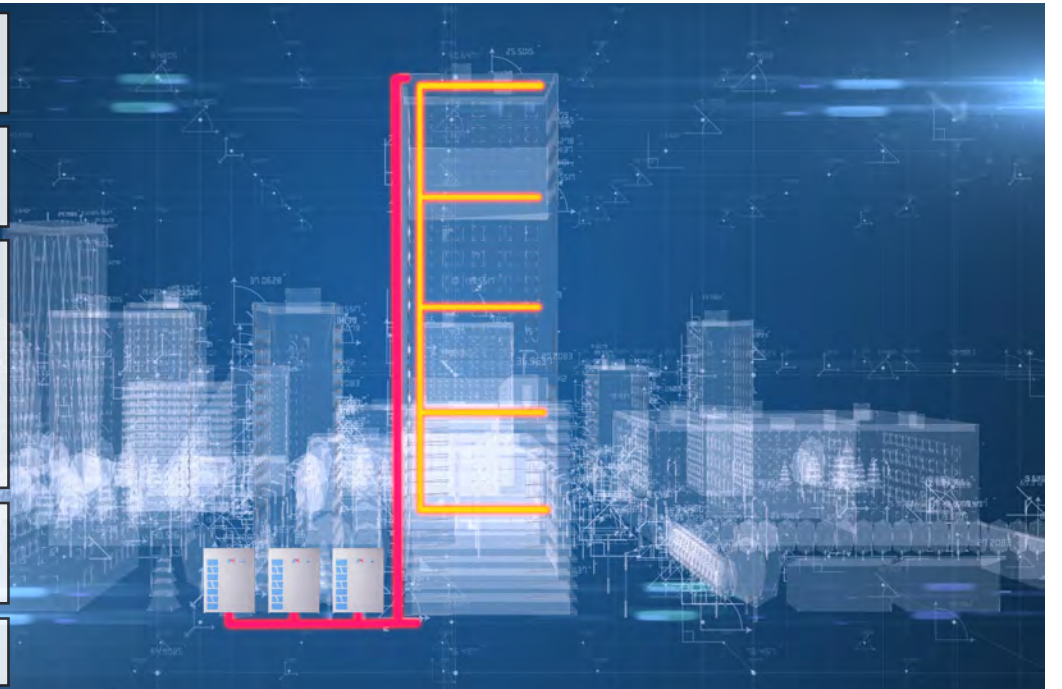

CONSISTENT FAN STATIC PRESSURE

Adaptive technology allows CHV6 systems to defrost while maintaining a steady static pressure, reducing room temperature fluctuation.

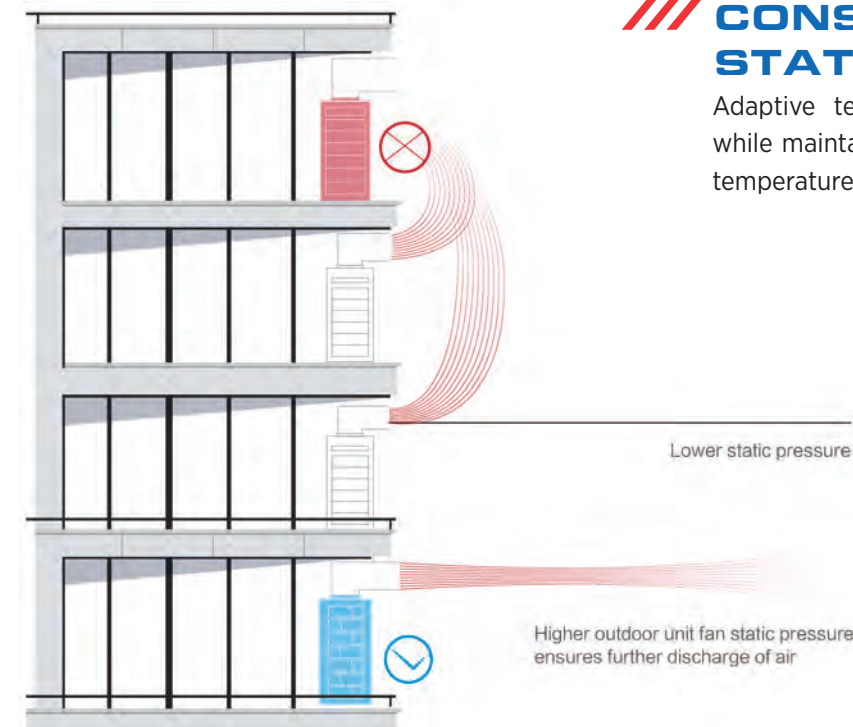

CHV6 URBAN

208~230V



CHV6 URBAN

208~230V

Model Name			CHV6-072URB	CHV6-096URB	CHV6-120URB	CHV6-144URB	CHV6-168URB	CHV6-192URB
Unit Group Configuration			1x CHV6-072URB	1x CHV6-096URB	1x CHV6-120URB	1x CHV6-144URB	1x CHV6-168URB	1x CHV6-192URB
Nominal Tonnage		RTU	6	8	10	12	14	16
Capacity	Cooling	Btu/h	69,000	92,000	114,000	138,000	160,000	184,000
	Heating	Btu/h	75,000	100,000	126,000	150,000	170,000	200,000
Input Power		kW	5.69/6.27	7.87/7.96	9.65/10.45	12.7/13.46	14.57/15.51	16.14/17.87
EER (Ducted/Non-Ducted)		Btu/h/W	12.15/14.80	11.80/14.05	11.80/13.90	10.85/12.10	11.0/11.85	11.40/11.85
COP 47°F (Ducted/Non-Ducted)		W/W	3.51/4.15	3.68/4.10	3.53/4.30	3.27/3.61	3.21/3.49	3.28/3.51
Power Supply		V/Ph/Hz	208-230V / 3Ph / 60Hz					
Electrical Parameters	MCA	A	34.3	41.2	49.3	60.1	62.3	78.1
	MOP	A	45	50	60	80	80	100
Max Connectable Indoor Units		N ^o	13	16	19	23	29	33
Sound Pressure Level		dB(A)	59	60	62	62	62	63
Dimensions	H	in.	68.13	68.13	68.13	68.13	68.13	68.13
	W	in.	37.09	37.09	47.63	53.16	53.16	63.00
	D	in.	29.22	29.22	29.22	29.22	29.22	29.22
Connection Pipe Diameter	Heat Recovery Operation System	Low Pressure Gas Pipe	3/4	7/8	1 1/8	1 1/8	1 1/8	1 1/8
		High/Low Pressure Gas Pipe	5/8	3/4	7/8	7/8	7/8	7/8
		Liquid Pipe	3/8	3/8	1/2	1/2	1/2	5/8
	Heat Pump Operation System	High/Low Pressure Gas Pipe	3/4	7/8	1 1/8	1 1/8	1 1/8	1 1/8
		Liquid Pipe	3/8	3/8	1/2	1/2	1/2	5/8
Refrigerant			R410A					
Compressor			Scroll Comp					
Compressor Quantity			1	1	1	2	2	2
Refrigerant Charge Before Shipment		lbs.	13.2	13.2	19.4	21.6	21.6	25.4
Weight	Net Weight	lbs.	534	536	637	796	798	858
	Gross Weight	lbs.	595	597	705	864	866	930
Total Piping Length		ft.	3,280					
Operation Range	Cooling	°F	14-126					
	Heating	°F	-13-62					

- The above cooling and heating capacities reflect the outdoor unit operating at 100% rating of indoor units, Cooling Operation Conditions: Indoor Air Inlet Temperature: 80°F DB 67°F WB, Outdoor Air Inlet Temperature: 95°F DB, Piping Length: 25ft., Piping Lift: 0ft., Heating Operation Conditions: Nominal Heating Condition, Indoor Air Inlet Temperature: 70°F DB, Outdoor Air Inlet Temperature: 47°F DB 43°F WB.
- Rated capacity and efficiency are certified under AHRI Standard 1230. Ratings are subject to change without notice. Current certified ratings are available at www.ahrirectory.org.
- The above noise values are measured in the anechoic chamber without reflected echo, therefore the impact of the reflected echo must be included at the scene. Measurement point: 3.3ft. from the service cover surface and 4.9ft. from floor level.
- The actual appearance of outdoor units may differ from photos.
- Specifications are subject to change without notice.

Model Name			CHV6-216URB	CHV6-240URB	CHV6-264URB	CHV6-288URB
Unit Group Configuration			1x CHV6-096URB 1x CHV6-120URB	2x CHV6-120URB	1x CHV6-120URB 1x CHV6-144URB	2x CHV6-144URB
Nominal Tonnage		RTU	18	20	22	24
Capacity	Cooling	Btu/h	206,000	228,000	252,000	275,500
	Heating	Btu/h	226,000	252,000	276,000	300,500
Input Power		kW	17.45/18.41	19.3/20.9	22.35/23.91	25.4/26.92
EER (Ducted/Non-Ducted)		Btu/h/W	11.81/13.96	11.81/13.89	11.26/12.86	10.85/12.11
COP 47°F (Ducted/Non-Ducted)		W/W	3.60/4.21	3.53/4.30	3.38/3.90	3.27/3.61
Power Supply		V/Ph/Hz	208-230V / 3Ph / 60Hz			
Electrical Parameters	MCA	A	41.2+49.3	49.3+49.3	49.3+60.1	60.1+60.1
	MOP	A	50+60	60+60	60+80	80+80
Max Connectable Indoor Units		N ^o	36	43	47	50
Sound Pressure Level		dB(A)	64	65	65	65
Dimensions	H	in.	68.13	68.13	68.13	68.13
	W	in.	37.09+47.63	47.63+47.63	47.63+53.16	53.16+53.16
	D	in.	29.22	29.22	29.22	29.22
Connection Pipe Diameter	Heat Recovery Operation System	Low Pressure Gas Pipe	1 1/8	1 1/4	1 1/4	1 1/4
		High/Low Pressure Gas Pipe	1 1/8	1 1/8	1 1/8	1 1/8
		Liquid Pipe	5/8	3/4	3/4	3/4
	Heat Pump Operation System	High/Low Pressure Gas Pipe	1 1/8	1 1/4	1 1/4	1 1/4
		Liquid Pipe	5/8	3/4	3/4	3/4
Refrigerant			R410A			
Compressor			Scroll Comp			
Compressor Quantity			1+1	1+1	1+2	2+2
Refrigerant Charge Before Shipment		lbs.	13.2+19.4	19.4+19.4	19.4+21.6	21.6+21.6
Weight	Net Weight	lbs.	536+637	637+637	637+796	796+796
	Gross Weight	lbs.	597+705	705+705	705+864	864+864
Total Piping Length		ft.	3,280			
Operation Range	Cooling	°F	14-126			
	Heating	°F	-13-62			

- The above cooling and heating capacities reflect the outdoor unit operating at 100% rating of indoor units, Cooling Operation Conditions: Indoor Air Inlet Temperature: 80°F DB 67°F WB, Outdoor Air Inlet Temperature: 95°F DB, Piping Length: 25ft., Piping Lift: 0ft., Heating Operation Conditions: Nominal Heating Condition, Indoor Air Inlet Temperature: 70°F DB, Outdoor Air Inlet Temperature: 47°F DB 43°F WB.
- Rated capacity and efficiency are certified under AHRI Standard 1230. Ratings are subject to change without notice. Current certified ratings are available at www.ahrirectory.org.
- The above noise values are measured in the anechoic chamber without reflected echo, therefore the impact of the reflected echo must be included at the scene. Measurement point: 3.3ft. from the service cover surface and 4.9ft. from floor level.
- The actual appearance of outdoor units may differ from photos.
- Specifications are subject to change without notice.

CHV6 URBAN

208~230V



CHV6 URBAN

208~230V

Model Name			CHV6-312URB	CHV6-336URB	CHV6-360URB	CHV6-384URB
Unit Group Configuration			1x CHV6-144URB 1x CHV6-168URB	2x CHV6-168URB	1x CHV6-168URB 1x CHV6-192URB	2x CHV6-192URB
Nominal Tonnage		RTU	26	28	30	32
Capacity	Cooling	Btu/h	298,000	320,000	344,000	368,000
	Heating	Btu/h	320,000	340,000	370,000	400,000
Input Power		kW	27.27/28.97	29.14/31.02	30.71/33.38	32.28/35.74
EER (Ducted/Non-Ducted)		Btu/h/W	10.92/11.98	10.99/11.84	11.19/11.84	11.40/11.84
COP 47°F (Ducted/Non-Ducted)		W/W	3.24/3.54	3.21/3.49	3.25/3.50	3.28/3.51
Power Supply		V/Ph/Hz	208-230V / 3Ph / 60Hz			
Electrical Parameters	MCA	A	60.1+62.3	62.3+62.3	62.3+78.1	78.1+78.1
	MOP	A	80+80	80+80	80+100	100+100
Max Connectable Indoor Units		N ²	53	59	64	64
Sound Pressure Level		dB(A)	65	65	66	66
Dimensions		H W D	68.13 53.16+53.16 29.22	68.13 53.16+53.16 29.22	68.13 53.16+63 29.22	68.13 63+63 29.22
Connection Pipe Diameter	Heat Recovery Operation System	Low Pressure Gas Pipe	1 1/4	1 1/2	1 1/2	1 1/2
		High/Low Pressure Gas Pipe	1 1/8	1 1/8	1 1/4	1 1/4
		Liquid Pipe	3/4	3/4	3/4	3/4
	Heat Pump Operation System	High/Low Pressure Gas Pipe	1 1/4	1 1/2	1 1/2	1 1/2
		Liquid Pipe	3/4	3/4	3/4	3/4
Refrigerant			R410A			
Compressor			Scroll Comp			
Compressor Quantity			2+2	2+2	2+2	2+2
Refrigerant Charge Before Shipment		lbs.	21.6+21.6	21.6+21.6	21.6+25.4	25.4+25.4
Weight	Net Weight	lbs.	796+798	798+798	798+858	858+858
	Gross Weight	lbs.	864+866	866+866	866+930	930+930
Total Piping Length		ft.	3,280			
Operation Range	Cooling	°F	14-126			
	Heating	°F	-13-62			

- The above cooling and heating capacities reflect the outdoor unit operating at 100% rating of indoor units, Cooling Operation Conditions: Indoor Air Inlet Temperature: 80°F DB 67°F WB, Outdoor Air Inlet Temperature: 95°F DB, Piping Length: 25ft., Piping Lift: 0ft., Heating Operation Conditions: Nominal Heating Condition, Indoor Air Inlet Temperature: 70°F DB, Outdoor Air Inlet Temperature: 47°F DB 43°F WB.
- Rated capacity and efficiency are certified under AHRI Standard 1230. Ratings are subject to change without notice. Current certified ratings are available at www.ahridirectory.org.
- The above noise values are measured in the anechoic chamber without reflected echo, therefore the impact of the reflected echo must be included at the scene. Measurement point: 3.3ft. from the service cover surface and 4.9ft. from floor level.
- The actual appearance of outdoor units may differ from photos.
- Specifications are subject to change without notice.

Model Name			CHV6-408URB	CHV6-432URB	CHV6-456URB
Unit Group Configuration			1x CHV6-120URB 2x CHV6-144URB	3x CHV6-144URB	2x CHV6-144URB 1x CHV6-168URB
Nominal Tonnage		RTU	34	36	38
Capacity	Cooling	Btu/h	389,500	413,500	435,500
	Heating	Btu/h	426,000	450,500	470,000
Input Power		kW	35.05/37.37	38.1/40.38	39.97/42.43
EER (Ducted/Non-Ducted)		Btu/h/W	11.12/12.59	10.85/12.11	10.88/12.01
COP 47°F (Ducted/Non-Ducted)		W/W	3.34/3.79	3.27/3.61	3.25/3.57
Power Supply		V/Ph/Hz	208-230V / 3Ph / 60Hz		
Electrical Parameters	MCA	A	49.3+60.1+60.1	60.1+60.1+60.1	60.1+60.1+ 60.3
	MOP	A	60+80+80	80+80+80	80+80+80
Max Connectable Indoor Units		N ²	64	64	64
Sound Pressure Level		dB(A)	67	67	67
Dimensions		H W D	68.13 47.63+53.16+53.16 29.22	68.13 53.16+53.16+53.16 29.22	68.13 53.16+53.16+53.16 29.22
Connection Pipe Diameter	Heat Recovery Operation System	Low Pressure Gas Pipe	1 1/2	1 1/2	1 1/2
		High/Low Pressure Gas Pipe	1 1/4	1 1/4	1 1/4
		Liquid Pipe	3/4	3/4	3/4
	Heat Pump Operation System	High/Low Pressure Gas Pipe	1 1/2	1 1/2	1 1/2
		Liquid Pipe	3/4	3/4	3/4
Refrigerant			R410A		
Compressor			Scroll Comp		
Compressor Quantity			1+2+2	2+2+2	2+2+2
Refrigerant Charge Before Shipment		lbs.	19.4+21.6+21.6	21.6+21.6+21.6	21.6+21.6+21.6
Weight	Net Weight	lbs.	637+796+796	796+796+796	796+796+798
	Gross Weight	lbs.	705+864+864	864+864+864	864+864+866
Total Piping Length		ft.	3,280.8		
Operation Range	Cooling	°F	14-126		
	Heating	°F	-13-62		

- The above cooling and heating capacities reflect the outdoor unit operating at 100% rating of indoor units, Cooling Operation Conditions: Indoor Air Inlet Temperature: 80°F DB 67°F WB, Outdoor Air Inlet Temperature: 95°F DB, Piping Length: 25ft., Piping Lift: 0ft., Heating Operation Conditions: Nominal Heating Condition, Indoor Air Inlet Temperature: 70°F DB, Outdoor Air Inlet Temperature: 47°F DB 43°F WB.
- Rated capacity and efficiency are certified under AHRI Standard 1230. Ratings are subject to change without notice. Current certified ratings are available at www.ahridirectory.org.
- The above noise values are measured in the anechoic chamber without reflected echo, therefore the impact of the reflected echo must be included at the scene. Measurement point: 3.3ft. from the service cover surface and 4.9ft. from floor level.
- The actual appearance of outdoor units may differ from photos.
- Specifications are subject to change without notice.

CHV6 URBAN

460V



CHV6 URBAN

460V

Model Name			CHV6-072SRB	CHV6-096SRB	CHV6-120SRB	CHV6-144SRB	CHV6-168SRB	CHV6-192SRB
Unit Group Configuration			1x CHV6-072SRB	1x CHV6-096SRB	1x CHV6-120SRB	1x CHV6-144SRB	1x CHV6-168SRB	1x CHV6-192SRB
Nominal Tonnage		RTU	6	8	10	12	14	16
Capacity	Cooling	Btu/h	69,000	92,000	114,000	138,000	160,000	184,000
	Heating	Btu/h	75,000	100,000	126,000	150,000	170,000	200,000
Input Power		kW	6.05/6.47	8.29/8.35	10.27/10.79	13.14/13.71	15.38/15.56	17.2/18.2
EER (Ducted/Non-Ducted)		Btu/h/W	11.4/13.9	11.1/13.2	11.1/13.0	10.5/11.4	10.4/11.1	10.7/11.2
COP 47°F (Ducted/Non-Ducted)		W/W	3.40/4.03	3.57/3.98	3.42/4.17	3.21/3.50	3.20/3.39	3.22/3.40
Power Supply		V/Ph/Hz	460V / 3Ph / 60Hz					
Electrical Parameters	MCA	A	18.4	23.4	25.8	29.0	35.1	39.8
	MOP	A	30	40	40	40	45	50
Max Connectable Indoor Units		N ²	13	16	19	23	29	33
Sound Pressure Level		dB(A)	59	60	62	62	62	63
Dimensions	H	in.	68.13	68.13	68.13	68.13	68.13	68.13
	W	in.	37.09	37.09	47.63	53.16	53.16	63.00
	D	in.	29.22	29.22	29.22	29.22	29.22	29.22
Connection Pipe Diameter	Heat Recovery Operation System	Low Pressure Gas Pipe	3/4	7/8	1 1/8	1 1/8	1 1/8	1 1/8
		High/Low Pressure Gas Pipe	5/8	3/4	7/8	7/8	7/8	7/8
		Liquid Pipe	3/8	3/8	1/2	1/2	1/2	5/8
	Heat Pump Operation System	High/Low Pressure Gas Pipe	3/4	7/8	1 1/8	1 1/8	1 1/8	1 1/8
		Liquid Pipe	3/8	3/8	1/2	1/2	1/2	5/8
Refrigerant			R410A					
Compressor			Scroll Comp					
Compressor Quantity			1	1	1	2	2	2
Refrigerant Charge Before Shipment		lbs.	13.2	13.2	19.4	21.6	21.6	25.4
Weight	Net Weight	lbs.	549	549	670	820	822	886
	Gross Weight	lbs.	608	608	738	893	895	970
Total Piping Length		ft.	3,280					
Operation Range	Cooling	°F	14-126					
	Heating	°F	-13-62					

- The above cooling and heating capacities reflect the outdoor unit operating at 100% rating of indoor units, Cooling Operation Conditions: Indoor Air Inlet Temperature: 80°F DB 67°F WB, Outdoor Air Inlet Temperature: 95°F DB, Piping Length: 25ft., Piping Lift: 0ft., Heating Operation Conditions: Nominal Heating Condition, Indoor Air Inlet Temperature: 70°F DB, Outdoor Air Inlet Temperature: 47°F DB 43°F WB.
- Rated capacity and efficiency are certified under AHRI Standard 1230. Ratings are subject to change without notice. Current certified ratings are available at www.ahridirectory.org.
- The above noise values are measured in the anechoic chamber without reflected echo, therefore the impact of the reflected echo must be included at the scene. Measurement point: 3.3ft. from the service cover surface and 4.9ft. from floor level.
- The actual appearance of outdoor units may differ from photos.
- Specifications are subject to change without notice.

Model Name			CHV6-216SRB	CHV6-240SRB	CHV6-264SRB	CHV6-288SRB
Unit Group Configuration			1x CHV6-096SRB 1x CHV6-120SRB	2x CHV6-120SRB	1x CHV6-120SRB 1x CHV6-144SRB	2x CHV6-144SRB
Nominal Tonnage		RTU	18	20	22	24
Capacity	Cooling	Btu/h	206,000	228,000	252,000	276,000
	Heating	Btu/h	226,000	252,000	276,000	300,000
Input Power		kW	18.56/19.97	20.54/22.03	24.00/24.66	27.06/27.24
EER (Ducted/Non-Ducted)		Btu/h/W	11.1/12.4	11.1/12.4	10.5/11.5	10.2/10.8
COP 47°F (Ducted/Non-Ducted)		W/W	3.4/3.88	3.35/3.80	3.28/3.59	3.23/3.33
Power Supply		V/Ph/Hz	460V / 3Ph / 60Hz			
Electrical Parameters	MCA	A	23.4+25.8	25.8+25.8	25.8+29.0	29.0+29.0
	MOP	A	40+40	40+40	40+40	40+40
Max Connectable Indoor Units		N ²	36	43	47	50
Sound Pressure Level		dB(A)	64	65	65	65
Dimensions	H	in.	68.13	68.13	68.13	68.13
	W	in.	37.09+47.63	47.63+47.63	47.63+53.16	53.16+53.16
	D	in.	29.22	29.22	29.22	29.22
Connection Pipe Diameter	Heat Recovery Operation System	Low Pressure Gas Pipe	1 1/8	1 1/4	1 1/4	1 1/4
		High/Low Pressure Gas Pipe	1 1/8	1 1/8	1 1/8	1 1/8
		Liquid Pipe	5/8	3/4	3/4	3/4
	Heat Pump Operation System	High/Low Pressure Gas Pipe	1 1/8	1 1/4	1 1/4	1 1/4
		Liquid Pipe	5/8	3/4	3/4	3/4
Refrigerant			R410A			
Compressor			Scroll Comp			
Compressor Quantity			1+1	1+1	1+2	2+2
Refrigerant Charge Before Shipment		lbs.	13.2+19.4	19.4+19.4	19.4+21.6	21.6+21.6
Weight	Net Weight	lbs.	549+670	670+670	670+820	820+820
	Gross Weight	lbs.	608+738	738+738	738+893	893+893
Total Piping Length		ft.	3,280			
Operation Range	Cooling	°F	14-126			
	Heating	°F	-13-62			

- The above cooling and heating capacities reflect the outdoor unit operating at 100% rating of indoor units, Cooling Operation Conditions: Indoor Air Inlet Temperature: 80°F DB 67°F WB, Outdoor Air Inlet Temperature: 95°F DB, Piping Length: 25ft., Piping Lift: 0ft., Heating Operation Conditions: Nominal Heating Condition, Indoor Air Inlet Temperature: 70°F DB, Outdoor Air Inlet Temperature: 47°F DB 43°F WB.
- Rated capacity and efficiency are certified under AHRI Standard 1230. Ratings are subject to change without notice. Current certified ratings are available at www.ahridirectory.org.
- The above noise values are measured in the anechoic chamber without reflected echo, therefore the impact of the reflected echo must be included at the scene. Measurement point: 3.3ft. from the service cover surface and 4.9ft. from floor level.
- The actual appearance of outdoor units may differ from photos.
- Specifications are subject to change without notice.

CHV6 URBAN

460V



CHV6 URBAN

460V

Model Name			CHV6-312SRB	CHV6-336SRB	CHV6-360SRB	CHV6-384SRB
Unit Group Configuration			1x CHV6-144SRB 1x CHV6-168SRB	2x CHV6-168SRB	1x CHV6-168SRB 1x CHV6-192SRB	2x CHV6-192SRB
Nominal Tonnage		RTU	26	28	30	32
Capacity	Cooling	Btu/h	298,000	320,000	344,000	368,000
	Heating	Btu/h	320,000	340,000	370,000	400,000
Input Power		kW	29.22/29.3	31.07/31.13	33.08/33.88	35.73/36.63
EER (Ducted/Non-Ducted)		Btu/h/W	10.2/10.7	10.3/10.6	10.4/10.6	10.3/10.5
COP 47°F (Ducted/Non-Ducted)		W/W	3.2/3.26	3.2/3.24	3.2/3.24	3.2/3.23
Power Supply		V/Ph/Hz	460V / 3Ph / 60Hz			
Electrical Parameters	MCA	A	29.0+35.1	35.1+35.1	35.1+39.8	39.8+39.8
	MOP	A	40+45	45+45	45+50	50+50
Max Connectable Indoor Units		N ²	53	59	64	64
Sound Pressure Level		dB(A)	65	65	66	66
Dimensions		H W D	68.13 53.16+53.16 29.22	68.13 53.16+53.16 29.22	68.13 53.16+63 29.22	68.13 63+63 29.22
Connection Pipe Diameter	Heat Recovery Operation System	Low Pressure Gas Pipe	1 1/4	1 1/2	1 1/2	1 1/2
		High/Low Pressure Gas Pipe	1 1/8	1 1/8	1 1/4	1 1/4
		Liquid Pipe	3/4	3/4	3/4	3/4
	Heat Pump Operation System	High/Low Pressure Gas Pipe	1 1/4	1 1/2	1 1/2	1 1/2
		Liquid Pipe	3/4	3/4	3/4	3/4
Refrigerant			R410A			
Compressor			Scroll Comp			
Compressor Quantity			2+2	2+2	2+2	2+2
Refrigerant Charge Before Shipment		lbs.	21.6+21.6	21.6+21.6	21.6+25.4	25.4+25.4
Weight	Net Weight	lbs.	820+822	822+822	822+886	886+886
	Gross Weight	lbs.	893+895	895+895	895+970	970+970
Total Piping Length		ft.	3,280			
Operation Range	Cooling	°F	14-126			
	Heating	°F	-13-62			

- The above cooling and heating capacities reflect the outdoor unit operating at 100% rating of indoor units, Cooling Operation Conditions: Indoor Air Inlet Temperature: 80°F DB 67°F WB, Outdoor Air Inlet Temperature: 95°F DB, Piping Length: 25ft., Piping Lift: 0ft., Heating Operation Conditions: Nominal Heating Condition, Indoor Air Inlet Temperature: 70°F DB, Outdoor Air Inlet Temperature: 47°F DB 43°F WB.
- Rated capacity and efficiency are certified under AHRI Standard 1230. Ratings are subject to change without notice. Current certified ratings are available at www.ahridirectory.org.
- The above noise values are measured in the anechoic chamber without reflected echo, therefore the impact of the reflected echo must be included at the scene. Measurement point: 3.3ft. from the service cover surface and 4.9ft. from floor level.
- The actual appearance of outdoor units may differ from photos.
- Specifications are subject to change without notice.

Model Name			CHV6-408SRB	CHV6-432SRB	CHV6-456SRB
Unit Group Configuration			1x CHV6-120SRB 2x CHV6-144SRB	3x CHV6-144SRB	2x CHV6-144SRB 1x CHV6-168SRB
Nominal Tonnage		RTU	34	36	38
Capacity	Cooling	Btu/h	388,000	414,000	436,000
	Heating	Btu/h	426,000	450,000	470,000
Input Power		kW	37.31/39.03	40.59/41.12	42.75/42.40
EER (Ducted/Non-Ducted)		Btu/h/W	10.4/11.0	10.2/10.8	10.2/10.7
COP 47°F (Ducted/Non-Ducted)		W/W	3.2/3.4	3.21/3.33	3.25/3.29
Power Supply		V/Ph/Hz	460V / 3Ph / 60Hz		
Electrical Parameters	MCA	A	25.8+29+29	29.0+29.0+29.0	29.0+29.0+35.1
	MOP	A	40+40+40	40+40+40	40+40+45
Max Connectable Indoor Units		N ²	64	64	64
Sound Pressure Level		dB(A)	67	67	67
Dimensions		H W D	68.13 47.63+53.16+53.16 29.22	68.13 53.16+53.16+53.16 29.22	68.13 53.16+53.16+53.16 29.22
Connection Pipe Diameter	Heat Recovery Operation System	Low Pressure Gas Pipe	1 1/2	1 1/2	1 1/2
		High/Low Pressure Gas Pipe	1 1/4	1 1/4	1 1/4
		Liquid Pipe	3/4	3/4	3/4
	Heat Pump Operation System	High/Low Pressure Gas Pipe	1 1/2	1 1/2	1 1/2
		Liquid Pipe	3/4	3/4	3/4
Refrigerant			R410A		
Compressor			Scroll Comp		
Compressor Quantity			1+2+2	2+2+2	2+2+2
Refrigerant Charge Before Shipment		lbs.	19.4+21.6+21.6	21.6+21.6+21.6	21.6+21.6+21.6
Weight	Net Weight	lbs.	670+820+820	820+820+820	820+820+822
	Gross Weight	lbs.	738+893+893	893+893+893	893+893+895
Total Piping Length		ft.	3,280.8		
Operation Range	Cooling	°F	14-126		
	Heating	°F	-13-62		

- The above cooling and heating capacities reflect the outdoor unit operating at 100% rating of indoor units, Cooling Operation Conditions: Indoor Air Inlet Temperature: 80°F DB 67°F WB, Outdoor Air Inlet Temperature: 95°F DB, Piping Length: 25ft., Piping Lift: 0ft., Heating Operation Conditions: Nominal Heating Condition, Indoor Air Inlet Temperature: 70°F DB, Outdoor Air Inlet Temperature: 47°F DB 43°F WB.
- Rated capacity and efficiency are certified under AHRI Standard 1230. Ratings are subject to change without notice. Current certified ratings are available at www.ahridirectory.org.
- The above noise values are measured in the anechoic chamber without reflected echo, therefore the impact of the reflected echo must be included at the scene. Measurement point: 3.3ft. from the service cover surface and 4.9ft. from floor level.
- The actual appearance of outdoor units may differ from photos.
- Specifications are subject to change without notice.



WIDER OPERATION RANGE

Wider operation range creates larger application potential. In cooling mode the operation range is from 23°F to 126°F and in heating mode is from -22°F to 62°F, which ensures the stable operation under extreme conditions. It allows simultaneous cooling and heating operation at temperatures ranging from -4°F to 81°F.

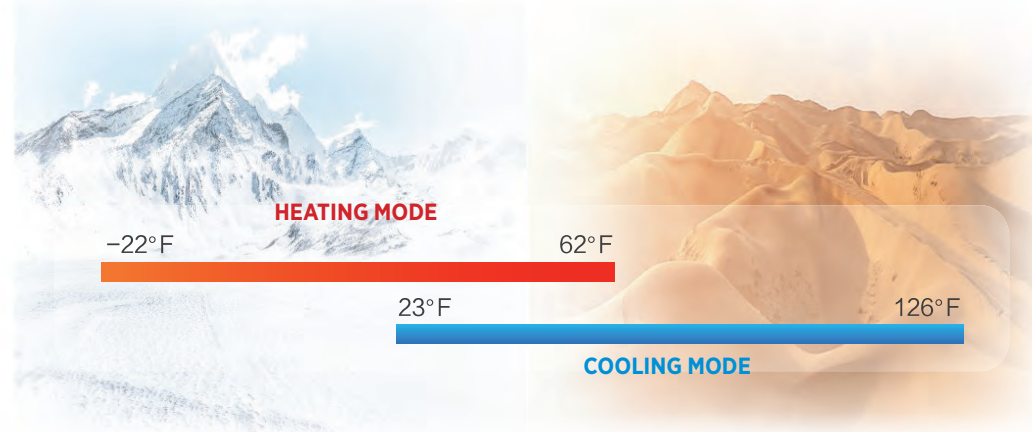

RELIABLE PERFORMANCE IN LOW TEMPERATURES

Compared with the standard series, the heating capacity of Hyper series is significantly increased at extreme low temperatures. At -4°F, the unit can operate at more than 90% heating capacity, at -13°F, 85%, and maintain 60% when temperatures reach -22°F.*

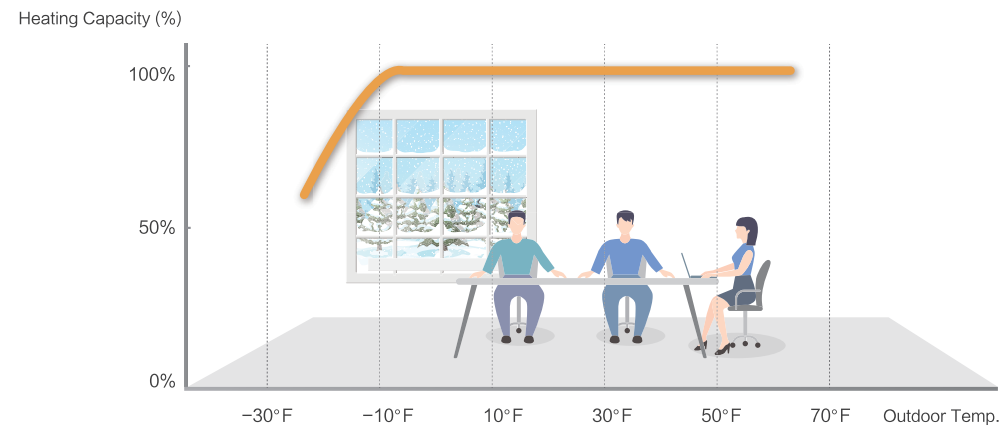

SNOW HOOD (OPTIONAL)

Heavy snow accumulation could affect heat exchange capacity. With the snow hood kit, the unit can prevent heavy snow from accumulating on top, protecting the heat exchanger and ensuring its stable operation.

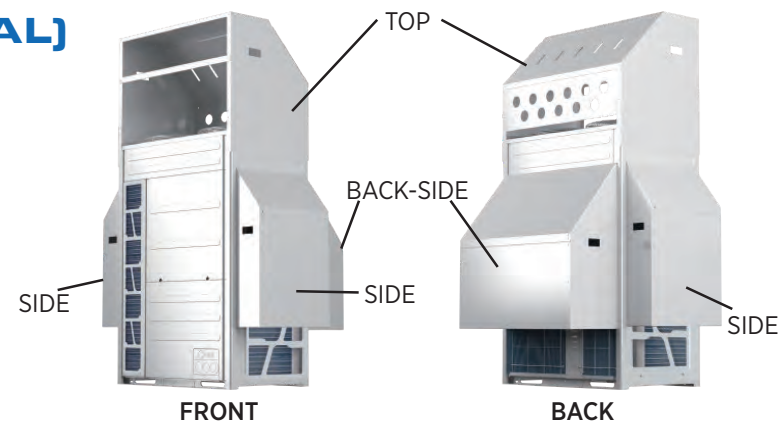

Model Name			CHV6-072URBHH	CHV6-096URBHH	CHV6-120URBHH	CHV6-144URBHH	CHV6-192URBHH	CHV6-240URBHH
Unit Group Configuration			1x CHV6-072URBHH	1x CHV6-096URBHH	1x CHV6-120URBHH	2x CHV6-072URBHH	2x CHV6-096URBHH	2x CHV6-120URBHH
Nominal Tonnage		RTU	6	8	10	12	16	20
Capacity	Cooling	Btu/h	72,000	96,000	120,000	144,000	192,000	240,000
	Heating	Btu/h	81,000	103,000	129,000	162,000	206,000	258,000
Input Power		kW	6.0/6.45	8.19/8.05	10.04/10.19	11.52/12.74	16.67/16.77	21.07/20.08
EER (Ducted/Non-Ducted)		Btu/h/W	12.0/12.8	11.7/12.5	12/12	12.5/12.2	11.5/11.8	11.4/11.8
COP 47°F (Ducted/Non-Ducted)		W/W	3.65/4.25	3.75/4.05	3.71/3.90	3.72/4.10	3.60/3.94	3.50/3.80
Low Temp. Heating Capacity (17°F)		Btu/h	81,000	103,000	129,000	162,000	206,000	258,000
COP 17°F (Ducted/Non-Ducted)		W/W	2.45/2.67	2.45/2.55	2.40/2.53	2.45/2.45	2.37/2.40	2.36/2.38
Power Supply		V/Ph/Hz	208-230V / 3Ph / 60Hz					
Electrical Parameters	MCA	A	63.8	67.4	71.2	63.8+63.8	67.4+67.4	71.2+71.2
	MOP	A	90	90	100	90+90	90+90	100+100
Max Connectable Indoor Units		N ^o	21	29	29	43	57	59
Sound Pressure Level		dB(A)	58	60	65	67	67	68
Dimensions	H	in.	68.13	68.13	68.13	68.13	68.13	68.13
	W	in.	53.16	53.16	53.16	53.16+ 53.16	53.16+ 53.16	53.16+ 53.16
	D	in.	29.22	29.22	29.22	29.22	29.22	29.22
Connection Pipe Diameter	Heat Recovery Operation System	Low Pressure Gas Pipe	3/4	7/8	1 1/8	1 1/8	1 1/8	1 3/8
		High/Low Pressure Gas Pipe	5/8	3/4	7/8	7/8	7/8	1 1/8
		Liquid Pipe	3/8	3/8	1/2	1/2	5/8	3/4
	Heat Pump Operation System	High/Low Pressure Gas Pipe	3/4	7/8	1 1/8	1 1/8	1 1/8	1 3/8
		Liquid Pipe	3/8	3/8	1/2	1/2	5/8	3/4
Refrigerant			R410A					
Compressor			Scroll Comp					
Compressor Quantity			2	2	2	2+2	2+2	2+2
Refrigerant Charge Before Shipment		lbs.	17.2	18.7	18.7	17.2+17.2	18.7+18.7	18.7+18.7
Weight	Net Weight	lbs.	796	798	800	796+796	798+798	800+800
	Gross Weight	lbs.	860	862	864	860+860	862+862	864+864
Total Piping Length		ft.	3,280					
Operation Range	Cooling	°F	23-126					
	Heating	°F	-22-62					

1. The above cooling and heating capacities reflect the outdoor unit operating at 100% rating of indoor units, Cooling Operation Conditions: Indoor Air Inlet Temperature: 80°F DB 67°F WB, Outdoor Air Inlet Temperature: 95°F DB, Piping Length: 25ft., Piping Lift: 0ft. Heating Operation Conditions: Nominal Heating Condition, Indoor Air Inlet Temperature: 70°F DB, Outdoor Air Inlet Temperature: 47°F DB 43°F WB.
 2. Rated capacity and efficiency are certified under AHRI Standard 1230. Ratings are subject to change without notice. Current certified ratings are available at www.ahridirectory.org.
 3. The above noise values are measured in the anechoic chamber without reflected echo, therefore the impact of the reflected echo must be included at the scene. Measurement point: 3.3ft. from the service cover surface and 4.9ft. from floor level.
 4. The actual appearance of outdoor units may differ from photos.
 5. Specifications are subject to change without notice.



CHV6 URBAN

HYPER HEAT 460V

CHV6 MINI URBAN

Model Name			CHV6-072SRBHH	CHV6-096SRBHH	CHV6-120SRBHH	CHV6-144SRBHH	CHV6-192SRBHH	CHV6-240SRBHH	
Unit Group Configuration			1x CHV6-072SRBHH	1x CHV6-096SRBHH	1x CHV6-120SRBHH	2x CHV6-072SRBHH	2x CHV6-096SRBHH	2x CHV6-120SRBHH	
Nominal Tonnage			6	8	10	12	16	20	
Capacity	Cooling	Btu/h	72,000	96,000	120,000	144,000	192,000	240,000	
	Heating	Btu/h	81,000	103,000	129,000	162,000	206,000	258,000	
Input Power			kW	6.0/6.45	8.19/8.05	10.04/10.19	11.52/12.74	16.67/16.77	21.07/20.08
EER (Ducted/Non-Ducted)			Btu/h/W	12.0/12.8	11.7/12.5	12/12	12.5/12.2	11.5/11.8	11.4/11.8
COP 47°F (Ducted/Non-Ducted)			W/W	3.65/4.25	3.75/4.05	3.71/3.90	3.72/4.10	3.60/3.94	3.50/3.80
Power Supply			V/Ph/Hz	460V / 3Ph / 60Hz					
Electrical Parameters	MCA	A	31.7	33.7	35.7	31.7+31.7	33.7+33.7	35.7+35.7	
	MOP	A	45	45	50	45+45	45+45	50+50	
Max Connectable Indoor Units			N ^o	21	29	29	43	57	59
Sound Pressure Level			dB(A)	58	60	65	67	67	68
Dimensions	H	in.	68.13	68.13	68.13	68.13	68.13	68.13	
	W	in.	53.16	53.16	53.16	53.16+ 53.16	53.16+ 53.16	53.16+ 53.16	
	D	in.	29.22	29.22	29.22	29.22	29.22	29.22	
Connection Pipe Diameter	Heat Recovery Operation System	Low Pressure Gas Pipe	in.	3/4	7/8	1 1/8	1 1/8	1 1/8	1 3/8
		High/Low Pressure Gas Pipe	in.	5/8	3/4	7/8	7/8	7/8	1 1/8
		Liquid Pipe	in.	3/8	3/8	1/2	1/2	5/8	3/4
	Heat Pump Operation System	High/Low Pressure Gas Pipe	in.	3/4	7/8	1 1/8	1 1/8	1 1/8	1 3/8
		Liquid Pipe	in.	3/8	3/8	1/2	1/2	5/8	3/4
Refrigerant			R410A						
Compressor			Scroll Comp						
Compressor Quantity			2	2	2	2+2	2+2	2+2	
Refrigerant Charge Before Shipment			lbs.	17.2	18.7	18.7	17.2+17.2	18.7+18.7	18.7+18.7
Weight	Net Weight	lbs.	816	818	820	816+816	818+818	820+820	
	Gross Weight	lbs.	895	897	899	895+895	897+897	899+899	
Total Piping Length			ft.	3,280					
Operation Range	Cooling	°F	23-126						
	Heating	°F	-22-62						

- The above cooling and heating capacities reflect the outdoor unit operating at 100% rating of indoor units, Cooling Operation Conditions: Indoor Air Inlet Temperature: 80°F DB 67°F WB, Outdoor Air Inlet Temperature: 95°F DB, Piping Length: 25ft., Piping Lift: 0ft.. Heating Operation Conditions: Nominal Heating Condition, Indoor Air Inlet Temperature: 70°F DB, Outdoor Air Inlet Temperature: 47°F DB 43°F WB.
- Rated capacity and efficiency are certified under AHRI Standard 1230. Ratings are subject to change without notice. Current certified ratings are available at www.ahridirectory.org.
- The above noise values are measured in the anechoic chamber without reflected echo, therefore the impact of the reflected echo must be included at the scene. Measurement point: 3.3ft. from the service cover surface and 4.9ft. from floor level.
- The actual appearance of outdoor units may differ from photos.
- Specifications are subject to change without notice.

THE CHV6 MINI URBAN SERIES CREATES A HIGH-QUALITY TRANQUIL ENVIRONMENT.

The lattice design utilizes the concept of aircraft engine design, which follows the principle or aerodynamics to reduce noise significantly. The grille also improves safety as it prevents children's fingers from being injured by the fan blades.



EXTENDED REFRIGERANT PIPING

The lattice design utilizes the concept of aircraft engine design, which follows the principle or aerodynamics to reduce noise significantly. The grille also improves safety as it prevents children's fingers from being injured by the fan blades.

Tons		2	3/4/5
Power Supply		208-230 / 1Ph / 60Hz	
Total Piping Length - Lto=Lt+LO+L1+L2...		197 ft	394 ft
Longest Length actual - Lt		164 ft	246 ft
Longest Length after first Branch - L		66 ft	98 ft
Level Difference between Outdoor Unit and Indoor Unit	Outdoor Unit is Higher - H1	66 ft	98 ft
	Outdoor Unit is Lower - H2	66 ft	98 ft
Level Difference between Indoor Units H3		11 ft	33 ft

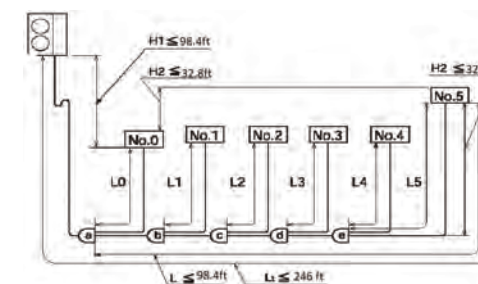

INSECT SCREENS

CHV6 systems are equipped with specialized screens which keep insects out of the unit, preventing unnecessary damage to electrical components.

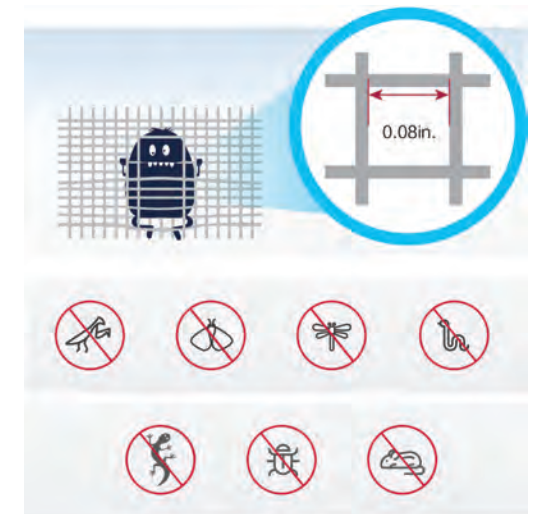



Model Name			CHV6-28URBM	CHV6-36URBM	CHV6-48URBM	CHV6-60URBM
Nominal Tonnage		RTU	2	3	4	5
Capacity	Cooling	Btu/h	27,000	36,000	48,000	57,500
	Heating	Btu/h	32,000	42,000	54,000	61,000
Input Power		kW	1.93/2.37	2.86/2.54	4.71/3.81	6.25/5.75
EER (Ducted/Non-Ducted)		Btu/h/W	11.0/11.5	12.6/14.2	10.2/1.6	9.2/10
Power Supply		V/Ph/Hz	208-230V / 1Ph / 60Hz			
Electrical Parameters	MCA	A	25.3	31.4	32.8	33.2
	MOP	A	35	40	45	45
Max Connectable Indoor Units		Qty	5	9	11	11
Sound Pressure Level		dB(A)	52	52	55	56
Dimensions	H		31.50	52.5	52.5	52.5
	W		37.41	37.41	37.41	37.41
	D		14.56	14.56	14.56	14.56
Connection Pipe Diameter	High/Low Pressure Gas Pipe	in.	5/8	5/8	5/8	5/8
	Liquid Pipe		3/8	3/8	3/8	3/8
Refrigerant			R410A			
Compressor			Rotary			
Compressor Quantity			1	1	1	1
Weight	Net Weight	lbs.	172	229	229	231
	Gross Weight		194	256	256	256
Piping Design	Height Diff between ODU and IDU	ft.	66	98.4	98.4	98.4
	Height Diff between IDUs		11	32.8	32.8	32.8
	Total Piping Length		197	394	394	394
Operation Range	Cooling	°F	23-114			
	Heating	°F	-4-60			

- The above cooling and heating capacities reflect the outdoor unit operating at 100% rating of indoor units, Cooling Operation Conditions: Indoor Air Inlet Temperature: 80°F DB 67°F WB, Outdoor Air Inlet Temperature: 95°F DB, Piping Length: 25ft., Piping Lift: 0ft., Heating Operation Conditions: Nominal Heating Condition, Indoor Air Inlet Temperature: 70°F DB, Outdoor Air Inlet Temperature: 47°F DB 43°F WB
- Rated capacity and efficiency are certified under AHRI Standard 1230. Ratings are subject to change without notice. Current certified ratings are available at www.ahridirectory.org.
- The above noise values are measured in the anechoic chamber without reflected echo, therefore the impact of the reflected echo must be included at the scene. Measurement point: 3.3ft. from the service cover surface and 4.9ft. from floor level.
- The actual appearance of outdoor units may differ from photos.
- Specifications are subject to change without notice.

GENERAL FEATURES & FUNCTIONS

- 4-WAY CEILING CASSETTE
- 4-WAY MINI CEILING CASSETTE
- 1 WAY CASSETTE
- FLOOR CEILING CONSOLE
- SLIM DUCTS LOW STATIC PRESSURE
- SLIM DUCTS HIGH STATIC PRESSURE
- WALL MOUNTS
- MULTI-POSITION AIR HANDLER UNIT
- AHU CONNECTION KITS
- HYDRO BOX



48-INCH DRAINAGE HEIGHT

Some CHV indoor models are equipped with a drain pump to pull condensation upward and remove water from the units with a drainage height of up to 48 inches.



SELF DIAGNOSIS

CHV indoor units use the self-diagnosis function to monitor and analyze malfunctions. Error codes are displayed on LED displays, remote controllers, or PCB boards as a general troubleshooting guide.



COMPACT SIZE

Compact indoor units can be conveniently transported and installed, even in small spaces.



REMOTE CONTROL

Indoor units can be controlled with wireless remote controller featuring an LCD display.



SILENT OPERATION

CHV units create minimal sound pressure during operation.



ADJUSTABLE LOUVER POSITION

CHV indoor units feature adjustable louvers for more precise directional air flow.



SWING LOUVER

CHV ceiling cassettes and wall mounts include louvers which swing automatically for even air distribution.



3D AIR FLOW PANEL (OPTIONAL)

The optional 3D air-flow panel, which includes an LED display and adjustable horizontal and vertical louvers, enables system control with a Cooper&Hunter wireless remote controller.



FAN SPEED

All CHV indoor units have 6 selectable fan speeds.



AUTO FAN SPEED

Fan speed rotation is automatically controlled to achieve optimum efficiency and comfort.



EASY MAINTENANCE

CHV indoor units provide convenient access to filters and other important components for easy upkeep and increased longevity.



WIDE CAPACITY RANGE

CHV indoor units come in a wide range of capacities across 5 different indoor model types.



AUTO RESTART

The automatic restart function sets the indoor units to automatically restart and resume previous settings in the event of a power outage.



LOW TEMPERATURE COOLING

The target temperature of indoor units can be set as low as 60°F.



WIFI ADAPTER (OPTIONAL)

An optional WiFi adapter can be installed to enable system control via iOS or Android smart device for up to 64 indoor units.



WIRELESS RECEIVER

Indoor units can be controlled via C&H wireless remote controller when a wireless receiver is installed. CHV wall mounts include a wireless receiver, but it is an optional accessory for other model types.



HUMIDITY SENSOR (OPTIONAL)

The optional humidity sensor allows access to more precise dehumidification control.



SMART HUMAN MOTION SENSOR

Intelligent motion sensing technology enables auto ON/OFF, auto fan, and auto temperature adjustments based on movement and occupancy of the room.



FRESH AIR INTRODUCTION

Fresh air can be directed into rooms with an optional adapter or direct connection to the air return segment of the unit.



STANDARD FILTER INCLUDED

A washable, long-life filter is included as a standard part.

CEILING CASSETTES

CONVENIENT DESIGN / SUITABLE FOR HIGH CEILINGS

The CVH 4-way Ceiling Cassette, available in 9.37 in and 8.46 in models, features a sophisticated design which fits in standard ceiling grids. CHV ceiling cassettes can be installed up to 13.78 ft high without interfering with airflow or air conditioning capabilities.

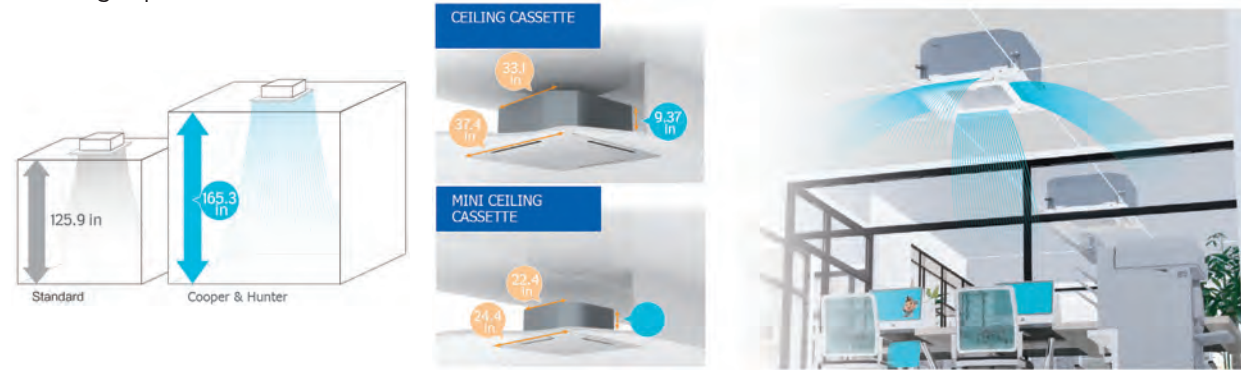

PRECISE LOUVER CONTROL

The louvers of CHV ceiling cassettes can be controlled individually with 6 angle settings and a maximum reach angle of 64°.



CEILING CASSETTE MOTION SENSOR

The smart motion sensor can be utilized for a variety of purposes. For example, it can automatically turn the unit on/off or direct the airflow towards or away from people, depending on the control settings. Additionally, in heavy-traffic times or areas, the temperature can automatically adjust to maintain a comfortable indoor climate.



Accessories Standard Cassettes										
Wired Controllers			Wireless Controller	Central Controller	Decoration Panel	Receiver Kit	Motion Sensor	Humidity Sensor	WIFI Adapter	Fresh Air Duct Adapter
SPWT-A01	SPWT-B01	SPWT-WG01	SPRC-101	SPCC-D10	SHP-G-NK	SPWRK-T03	SPHNS-01E	SPHDS-S01E	SPHM-64M	SPFA2.64

CEILING CASSETTES

4 WAY CEILING CASSETTE



Model Name			CHV-09SCC4W	CHV-12SCC4W	CHV-15SCC4W	CHV-19SCC4W	CHV-22SCC4W	CHV-24SCC4W
Capacity	Cooling	Btu/h	9,600	12,300	15,400	19,100	21,500	24,200
	Heating	Btu/h	10,900	13,700	17,100	21,500	24,200	27,300
Input Power		W	20	30	30	40	60	70
Power Supply		V/Ph/Hz	208-230V / 1Ph / 60Hz					
Electrical Parameters	MCA	A	1.19					
	MOP	A	15					
Airflow Rate		CFM	314/357/386/429/479/536	325/386/421/457/500/607	400/454/486/532/571/750	446/486/554/568/625/786	464/539/607/654/714/929	525/582/643/682/750/964
Sound Pressure Level		dB(A)	26/26/27/28/28/30	26/27/28/29/29/32	26/27/29/29/31/33	26/28/28/30/31/34	28/29/31/32/33/36	28/29/31/32/33/36
Dimensions (H x W x D)		in.	9.69x33.06x33.06					
Decoration Panel		in.	1.84x37.41x37.41					
Weight		lbs.	44	44	46	46	51	51
Connection Pipe Diameter	Liquid	in.	1/4	1/4	1/4	1/4	1/4	3/8
	Gas	in.	1/2	1/2	1/2	1/2	1/2	5/8
	Drain	in.	1 1/4	1 1/4	1 1/4	1 1/4	1 1/4	1 1/4

Model Name			CHV-27SCC4W	CHV-30SCC4W	CHV-38SCC4W	CHV-48SCC4W	CHV-54SCC4W
Capacity	Cooling	Btu/h	27,300	30,700	37,200	47,800	54,600
	Heating	Btu/h	30,700	34,100	42,700	54,600	61,400
Input Power		W	60	60	130	130	130
Power Supply		V/Ph/Hz	208-230V / 1Ph / 60Hz				
Electrical Parameters	MCA	A	1.19	1.19	2.15	2.15	2.15
	MOP	A	15				
Airflow Rate		CFM	550/600/668/725/786/964	575/632/700/739/821/964	700/800/886/979/1071/1321	800/864/971/1057/1196/1321	850/914/1032/1096/1214/1321
Sound Pressure Level		dB(A)	30/31/33/35/36/37	30/31/33/35/36/37	33/34/36/38/40/42	34/36/38/40/44/46	36/38/40/41/44/46
Dimensions (H x W x D)		in.	11.31x33.06x33.06				
Decoration Panel		in.	1.84x37.41x37.41				
Weight		lbs.	57	57	57	57	57
Connection Pipe Diameter	Liquid	in.	3/8	3/8	3/8	3/8	3/8
	Gas	in.	5/8	5/8	5/8	5/8	5/8
	Drain	in.	1 1/4	1 1/4	1 1/4	1 1/4	1 1/4

Bacnet	CH-Checker	Switch Boxes	
SPBN-H160	SPHCH-64	Single Box	Multi Box

- The nominal cooling capacity and heating capacity are based on the following conditions: Cooling Operation Conditions, Indoor Air Inlet Temperature: 80°F DB, 66°F WB, Outdoor Air Inlet Temperature: 95°F DB Piping Length: 24.6ft, Piping Lif: Oft Heating Operation Conditions, Indoor Air Inlet Temperature: 68°F DB, Outdoor Air Inlet Temperature: 44°F DB, 42°F WB
- The sound pressure level is based on the following conditions: 4.9ft beneath the unit. The above data was measured in an anechoic chamber so that the reflected sound should be taken into consideration in the field
- The actual appearance of outdoor units may differ from photos.
- Specifications are subject to change without notice.

CEILING CASSETTES

4 WAY MINI CEILING CASSETTE



Model Name		CHV-05MCC4W	CHV-07MCC4W	CHV-09MCC4W	CHV-12MCC4W	CHV-15MCC4W	CHV-17MCC4W	CHV-19MCC4W	
Capacity	Cooling	Btu/h	5,100	7,480	9,520	12,240	15,300	17,000	19,040
	Heating	Btu/h	6,800	8,500	11,220	14,280	17,000	19,040	21,420
Input Power	W	14	14	14	16	22	30	40	
Power Supply	V/Ph/Hz	208-230V / 1Ph / 60Hz							
Electrical Parameters	MCA	A	0.23	0.23	0.29	0.35	0.41	0.49	0.66
	MOP	A	15						
Airflow Rate	CFM	256/232/220/199	256/232/220/199	280/256/232/208	292/256/232/208	333/213/252/238	393/339/312/252	446/387/333/286	
Sound Pressure Level	dB(A)	30/29/28/26	30/29/28/26	32/30/28/26	34/32/29/26	38/36/31/28	42/39/36/31	45/42/38/34	
Dimensions (H x W x D)	in.	8.47x22.44x22.44							
Decoration Panel	in.	1.44x24.44x24.44							
Weight	lbs.	32	32	32.6	32.6	34.8	35	35	
Connection Pipe Diameter	Liquid	1/4							
	Gas	in.	1/2						
	Drain	1 1/4							

Accessories Mini Cassettes										
Wired Controllers			Wireless Controller	Central Controller	Decoration Panel	Receiver Kit	Motion Sensor	Humidity Sensor	WIFI Adapter	Fresh Air Duct Adapter
SPWT-A01	SPWT-B01	SPWT-WG01	SPRC-101	SPCC-D10	SHPE-D-NK	SPWRK-Z01	SPHNS-MACN	SPHDS-S01E	SPHM-64M	SPFA2.64

Bacnet	CH-Checker	Switch Boxes	
SPBN-H160	SPHCH-64	Single Box	Multi Box
<ol style="list-style-type: none"> The nominal cooling capacity and heating capacity are based on the following conditions: Cooling Operation Conditions, Indoor Air Inlet Temperature: 80°F DB, 66°F WB, Outdoor Air Inlet Temperature: 95°F, DB, Piping Length: 24.6ft, Piping Lif: 0ft, Heating Operation Conditions, Indoor Air Inlet Temperature: 68°F DB, Outdoor Air Inlet Temperature: 44°F DB, 42°F WB The sound pressure level is based on the following conditions: 4.9ft beneath the unit. The above data was measured in an anechoic chamber so that the reflected sound should be taken into consideration in the field The actual appearance of outdoor units may differ from photos. Specifications are subject to change without notice. 			

CEILING CASSETTES

1-WAY CASSETTE



Model Name		CHV-07CC1W	CHV-09CC1W	CHV-12CC1W	CHV-14CC1W	CHV-18CC1W	CHV-24CC1W	
Capacity	Cooling	Btu/h	7,500	9,600	12,300	15,400	19,100	24,200
	Heating	Btu/h	8,500	11,000	13,600	17,100	21,500	27,200
Input Power	W	20	30	40	40	50	100	
Power Supply	V/Ph/Hz	208-230V / 1Ph / 60Hz						
Electrical Parameters	MCA	A	0.48	0.48	0.48	0.48	1.11	1.11
	MOP	A	15					
Airflow Rate	CFM	219/208/198/180/170/163	233/219/198/180/170/163	293/258/240/219/198/180	353/293/240/223/201/184	427/350/311/290/275/233	551/445/396/350/297/251	
Sound Pressure Level	dB(A)	33/32/31/30/29/28	35/34/32/31/29/28	40/36/35/33/30/29	43/39/35/33/31/29	41/39/36/35/33/31	48/46/43/40/37/33	
Dimensions (H x W x D)	in.	7.56x35.81x18.5	7.56x35.81x18.5	7.56x35.81x18.5	7.56x35.81x18.5	7.56x46.44x18.5	7.56x46.44x18.5	
Decoration Panel	in.	2.19x43.31x21.63	2.19x43.31x21.63	2.19x43.31x21.63	2.19x43.31x21.63	2.19x53.94x21.63	2.19x53.94x21.63	
Weight	lbs.	42	42	44	44	53	53	
Connection Pipe Diameter	Liquid	in.	1/4	1/4	1/4	1/4	3/8	
	Gas	in.	1/2	1/2	1/2	1/2	5/8	
	Drain	VP25						

Accessories 1-Way Cassettes									
Wired Controllers			Wireless Controller	Central Controller	Decoration Panel	Receiver Kit	Motion Sensor	WIFI Adapter	Fresh Air Duct Adapter
SPWT-A01	SPWT-B01	SPWT-WG01	SPRC-101	SPCC-D10	SHP-D-NA SHP-E-NA	SPWRK-X01H	SPHNS-S01E	SPHM-64M	SPFA2.64

Bacnet	CH-Checker	Switch Boxes	
SPBN-H160	SPHCH-64	Single Box	Multi Box
<ol style="list-style-type: none"> The nominal cooling capacity and heating capacity are based on the following conditions: Cooling Operation Conditions, Indoor Air Inlet Temperature: 80°F DB, 66°F WB, Outdoor Air Inlet Temperature: 95°F, DB, Piping Length: 24.6ft, Piping Lif: 0ft, Heating Operation Conditions, Indoor Air Inlet Temperature: 68°F DB, Outdoor Air Inlet Temperature: 44°F DB, 42°F WB The sound pressure level is based on the following conditions: 4.9ft beneath the unit. The above data was measured in an anechoic chamber so that the reflected sound should be taken into consideration in the field The actual appearance of outdoor units may differ from photos. Specifications are subject to change without notice. 			



CONVENIENT INSTALLATION AND MAINTENANCE

The unit can be installed to be standing on floors or hanging on ceilings. Whereby interior walls maximized to display items or you can hang the unit on the ceiling.

Adjust the ceiling or wall mounting height by just opening the side panels without the need to access the internal parts. Service manholes are unnecessary due to the strategic repositioning of piping connections and electrical box behind the air return panel.

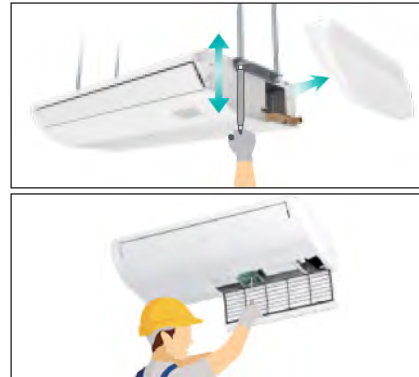

Louvers consist of horizontal and vertical flaps to cover larger coverage area to the edges of any rooms. Wider opening angle from up to 120° for vertical louvers and up to 71° for horizontal louvers supplies air further and lower down to floor.

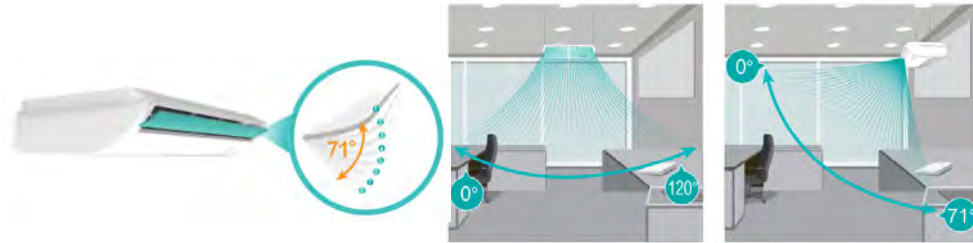

Model Name		CHV-18CFT	CHV-22CFT	CHV-24CFT	CHV-27CFT	CHV-30CFT	CHV-38CFT	CHV-48CFT
Capacity	Cooling	Btu/h 19,100	21,500	24,200	28,700	30,700	38,200	48,500
	Heating	Btu/h 19,800	22,200	24,900	29,700	31,700	39,600	49,500
Input Power	W	40	70	70	70	80	130	160
Power Supply	V/Ph/Hz	208-230V / 1Ph / 60Hz						
Electrical Parameters	MCA	A	0.43	0.64	0.64	1.2	1.2	2.15
	MOP	A	15					
Airflow Rate	CFM	459/389/318	569/495/399	569/495/399	643/537/431	685/576/470	876/724/576	1166/989/812
Sound Pressure Level	dB(A)	39/35/30/ 39/38/35	45/41/37/ 48/44/40	45/41/37/ 48/44/40	43/39/34/ 46/41/37	45/40/36/ 48/43/39	51/46/40 54/49/43	50/46/42 55/50/46
Dimensions (H x W x D)	in.	9x39x26.75	9x39x26.75	9x39x26.75	9x50.75x26.75	9x50.75x26.75	9x50.75x26.75	9x62.25x26.75
Weight	lbs.	72.7	75	75	90.4	90.4	90.4	108
Connection Pipe Diameter	Liquid	in.	1/4	3/8	3/8	3/8	3/8	3/8
	Gas	in.	5/8	5/8	5/8	5/8	5/8	5/8
	Drain		VP25					

Accessories Floor Ceilingr Unit										
Wired Controllers			Wireless Controller	Central Controller	Motion Sensor	WiFi Adapter	Bacnet	CH-Checker	Switch Boxes	
SPWT-A01	SPWT-B01	SPWT-WG01	SPRC-101	SPCC-D10	SPHNS-S01E	SPHM-64M	SPBN-H160	SPHCH-64	Single Box	Multi Box

ADJUSTABLE STATIC PRESSURE AND IMPROVED AIR QUALITY

The static pressure of the slim duct fan can be adjusted to suit various noise and air flow needs. Fresh air supply and filters ensure improved air quality.

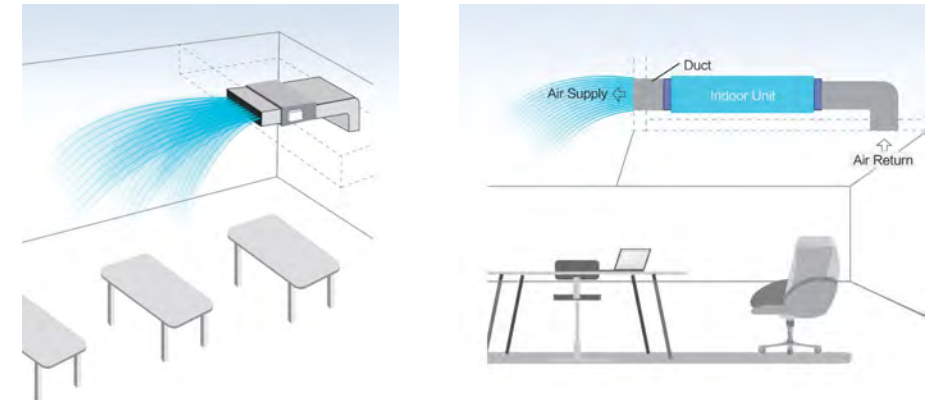

3D AIR FLOW PANEL (OPTIONAL)

The optional 3D air-flow panel, which includes an LED display and adjustable horizontal and vertical louvers, enables system control with a Cooper&Hunter wireless remote controller and the capability for more precise directional air flow.



TEMPERATURE PRECISION

CHV slim ducted units include 3 temperature sensors to prevent overcooling or overheating of the room. The sensors send real-time signals to the unit for more accurate temperature supply.

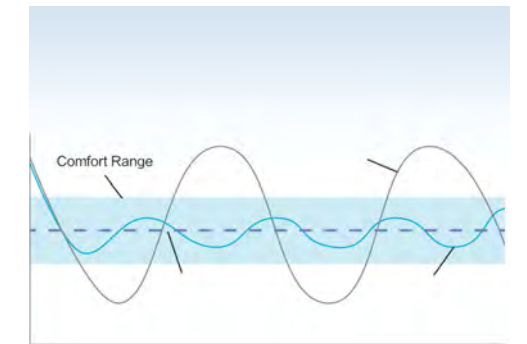

DRAIN PUMP

CHV low static pressure slim ducts include a standard drain pump and a maximum drain height of 47 inches. Internal and external drain pumps are optional accessories available for high static pressure slim ducts.

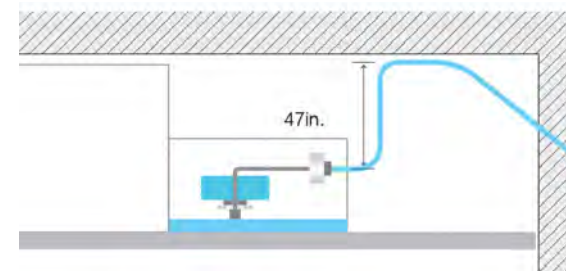

DEVICE CONNECTION OPTIONS

Third party building management systems and sensors can be connected to the indoor unit via dry contacts. Devices such as hotel room key card, window contact and fire alarm can be connected at the same time.

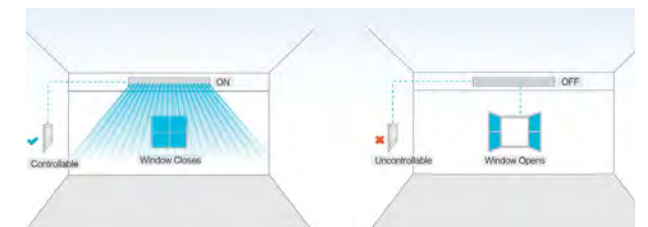

SLIM DUCTS

LOW STATIC PRESSURE



Model Name			CHV-05SDLSP	CHV-07SDLSP	CHV-09SDLSP	CHV-12SDLSP	CHV-15SDLSP	CHV-19SDLSP
Capacity	Cooling	Btu/h	5,800	7,500	9,600	12,300	15,300	19,100
	Heating	Btu/h	6,500	8,500	11,300	13,600	17,100	21,500
Input Power	W		30	30	50	50	60	60
Power Supply	V/Ph/Hz		208-230V / 1Ph / 60Hz					
Electrical Parameters	MCA	A	0.47	0.56	0.64	0.64	0.74	0.74
	MOP	A	15					
Airflow Rate	CFM		247/230/215/ 201/184/170	247/230/215/ 201/184/170	318/286/257/ 237/208/184	318/286/257/ 237/208/184	424/381/332/ 286/240/194	477/441/396/ 353/311/272
Sound Pressure Level	dB(A)		28/27/26/24/23/21	28/27/26/24/23/21	35/32/32/30/26/23	35/32/32/30/26/23	23/26/30/32/32/35	35/32/30/28/25/23
Static Pressure Range	in. WG		0.04 (0.04 - 0.12)	0.04 (0.04 - 0.12)	0.04 (0.04 - 0.12)	0.04 (0.04 - 0.12)	0.04 (0.04 - 0.12)	0.04 (0.04 - 0.12)
Dimensions (H x W x D)	in.		7.56x27.56x17.52	7.56x27.56x17.52	7.56x27.56x17.52	7.56x27.56x17.52	7.56x27.56x17.52	7.56x27.56x17.52
Weight	lbs.		35.3	35.3	37.5	37.5	44.1	52.9
Connection Pipe Diameter	Liquid		1/4					
	Gas	in.	1/2					
	Drain		VP25					

Model Name			CHV-22SDLSP	CHV-24SDLSP
Capacity	Cooling	Btu/h	21,500	24,200
	Heating	Btu/h	24,200	27,300
Input Power	W		90	240
Power Supply	V/Ph/Hz		208-230V / 1Ph / 60Hz	
Electrical Parameters	MCA	A	1.12	1.15
	MOP	A	15	
Airflow Rate	CFM		636/569/505/434/370/307	636/569/505/434/370/307
Sound Pressure Level	dB(A)		38/36/35/33/31/24	38/36/35/33/31/24
Static Pressure Range	in. WG		0.04 (0.04 - 0.12)	0.04 (0.04 - 0.12)
Dimensions (H x W x D)	in.		7.56x46.45x17.52	7.56x46.45x17.52
Weight	lbs.		52.9	52.9
Connection Pipe Diameter	Liquid		3/8	
	Gas	in.	5/8	
	Drain		VP25	

Accessories Low Static Pressure Ducted Unit												
Wired Controllers			Wireless Controller	Central Controller	Receiver Kit	Motion Sensor	Humidity Sensor	WIFI Adapter	Bacnet	CH-Checker	Switch Boxes	
SPWT-A01	SPWT-B01	SPWT-WG01	SPRC-101	SPCC-D10	SPWRK-V02	SPHNS-S01E	SPHDS-S01E	SPHM-64M	SPBN-H160	SPHCH-64	Single Box	Multi Box

SLIM DUCTS

HIGH STATIC PRESSURE



Model Name			CHV-07SDHSP	CHV-09SDHSP	CHV-12SDHSP	CHV-15SDHSP	CHV-19SDHSP	CHV-24SDHSP
Capacity	Cooling	Btu/h	7,500	9,600	12,300	15,400	19,100	24,200
	Heating	Btu/h	8,500	10,900	13,700	17,100	21,600	27,400
Input Power	W		40	40	55	55	55	82
Power Supply	V/Ph/Hz		208-230V / 1Ph / 60Hz					
Electrical Parameters	MCA	A	1.81	1.81	1.81	1.81	2.27	2.27
	MOP	A	15					
Airflow Rate	CFM		318/283/240/ 222/205/187	318/283/240/ 222/205/187	424/388/353/ 318/283/254	424/388/353/ 318/283/254	512/459/406/ 371/335/307	671/600/530/ 459/388/335
Sound Pressure Level	dB(A)		30/27/23/21/20/19	30/27/23/21/20/19	35/33/32/28/26/24	35/33/32/28/26/24	33/30/27/25/23/22	36/34/31/28/24/22
Static Pressure Range	in. WG		0.12/0.16/0.20/0.24/0.28/0.32/0.36/0.40/0.44/0.48/0.52/0.56/0.60					
Dimensions (H x W x D)	in.		10.63x28.55x28.34	10.63x28.55x28.34	10.63x28.55x28.34	10.63x28.55x28.34	10.63x38.55x28.34	10.63x28.55x28.34
Weight	lbs.		51	51	53	53	66	66
Connection Pipe Diameter	Liquid		1/4					
	Gas	in.	1/2					
	Drain		VP25					

Model Name			CHV-30SDHSP	CHV-38SDHSP	CHV-48SDHSP	CHV-54SDHSP	CHV-76SDHSP	CHV-96SDHSP
Capacity	Cooling	Btu/h	30,800	38,000	48,000	54,500	76,500	95,600
	Heating	Btu/h	34,200	42,500	54,500	61,500	85,300	107,500
Input Power	W		100	132	180	223	610	830
Power Supply	V/Ph/Hz		208-230V / 1Ph / 60Hz					
Electrical Parameters	MCA	A	2.68	2.68	5.04	5.04	5.57	7.92
	MOP	A	15					
Airflow Rate	CFM		883/812/742/ 671/600/530	989/883/812/ 742/671/600	1254/1148/1042/ 936/830/724	1377/1254/1095/ 936/830/770	2012/1906/1835/ 1800/1730/1677	2541/2400/2294/ 2153/2030/1765
Sound Pressure Level	dB(A)		34/32/30/28/25/22	37/35/31/29/26/23	38/36/34/31/29/26	41/38/35/33/30/27	49/48/47/46/45/44	53/52/50/49/47/44
Static Pressure Range	in. WG		0.20/0.24/0.28/0.32/0.36/0.40/0.44/0.48/0.52/0.56/0.60/0.64/0.68/0.72/0.76/0.80					
Dimensions (H x W x D)	in.		11.8x46.27x31.5	11.8x46.27x31.5	11.8x58.08x31.5	11.8x58.08x31.5	18.5x19.25x44.5	18.5x19.25x44.5
Weight	lbs.		88	88	108	108	229	229
Connection Pipe Diameter	Liquid		3/8					
	Gas	in.	5/8					
	Drain		VP25					

Accessories High Static Pressure Ducted Unit									
Wired Controllers			Wireless Controller	Central Controller	Receiver Kit	Motion Sensor	Humidity Sensor	WIFI Adapter	Drain Pump
SPWT-A01	SPWT-B01	SPWT-WG01	SPRC-101	SPCC-D10	SPWRK-V02	SPHNS-S01E	SPHDS-S01E	SPHM-64M	SPIDP-DHP07/24-27/54-76/96

Drain Pump	Bacnet	CH-Checker	Switch Boxes
SPEDP-DHP07/54	SPBN-H160	SPHCH-64	Single Box Multi Box

- The nominal cooling capacity is the combined capacity of the Cooper&Hunter standard split system. Cooling Operation Conditions Indoor Air Inlet Temperature: 80°F DB, 66°F WB, Outdoor Air Inlet Temperature: 95°F DB, Heating Operation Conditions Indoor Air Inlet Temperature: 68°F DB, Outdoor Air Inlet Temperature: 44°F DB, 42°F WB, Piping Length: 24.6ft, Piping Lift: 0ft
- The sound pressure level is based on following conditions: 4.9ft Beneath the Unit, With Discharge Duct(6.5ft.) and Return Duct(3.3ft.). Voltage of the power source for the indoor fan motor is 208V. The above data was measured in an anechoic chamber so that reflected sound should be taken into consideration in the field.
- The data for external pressure *1)indicates Standard Pressure Setting values when a filter is not used.
- The actual appearance of outdoor units may differ from photos.
- Specifications are subject to change without notice.

SLIM DUCTS

DOAS UNITS



/// SIMPLE & FLEXIBLE SYSTEM

Create a more comfortable, healthy indoor environment with the fresh air indoor unit which provides outdoor air ventilation and seamlessly integrates into a ducted VRF system.

/// HIGH STATIC PRESSURES OFFERED

/// DRAIN PUMP PRE-INSTALLED

Indoor Unit Type		Fresh Air Indoor Unit
Model Name		CHV-96FASD
Indoor Unit Power Supply		208-230V / 1Ph / 60Hz
Outlet Air Temperature Control*1 Nominal Cooling Capacity	Btu/h (kW)	96,000 (28.2)
Outlet Air Temperature Control*1 Nominal Heating Capacity	Btu/h (kW)	60,000 (17.6)
Indoor Temperature Control*2 Nominal Cooling Capacity	Btu/h (kW)	96,000 (28.2)
Indoor Temperature Control*2 Nominal Heating Capacity	Btu/h (kW)	83,600 (24.5)
Sound Pressure Level *3 (Overall A Scale) (208/230V)	dB	50/51
Outer Dimensions Height	in.(mm)	19-1/8. (486)
Outer Dimensions Width	in.(mm)	50 (1270)
Outer Dimensions Depth	in.(mm)	44-1/8 (1120)
Net Weight	lbs(kg)	247 (112)
Refrigerant		R410A
Indoor Fan Air Flow Rate	cfm (m/min)	1236 (35.0)
External Pressure (208/230V) High Pressure	in.W.G(Pa)	1.06/1.24 (265/310)
External Pressure (208/230V) Standard	in.W.G(Pa)	-
Motor Nominal Output	w	402 (201 x 2pcs)
Min Circuit Amps	A	4.3
Maximum Fuse Amps	A	15
Connections Refrigerant Piping Liquid Line	in.(mm)	Brazed 3/8 (9.520)
Connections Refrigerant Piping Gas Line	in.(mm)	Brazed 7/8 (22.20)
Condensate Drain OD	in.(mm)	VP25 1-1/4 (32)
Condensate Drain ID	in.(mm)	VP251 (25)

Temperature Range of Fresh Air: Cooling: 68°F - 109°F, Heating: 19°F - 68°F

Accessories High Static Pressure Ducted Unit									
Wired Controllers			Wireless Controller	Central Controller	Receiver Kit	Motion Sensor	Humidity Sensor	WiFi Adapter	Bacnet
SPWT-A01	SPWT-B01	SPWT-WG01	SPRC-101	SPCC-D10	SPWRK-V02	SPHNS-S01E	SPHDS-S01E	SPHM-64M	SPBN-H160

CH-Checker			Switch Boxes	
SPHCH-64	Single Box	Multi Box	<p>*1. Outlet Air Temperature Control: A control system to bring the outlet temperature closer to the set point temperature of the wired controller, using an outlet air thermistor of the unit. Nominal capacity (outlet air temperature control) is based on combination with VRF system and following conditions: Cooling Operation Conditions-Outdoor Temperature: 91°F DB (33.0°C DB) 82°F WB (28.0°C WB) Discharge Set Temperature: 61°F DB (16.0°C DB), Heating Operation Conditions Outdoor Temperature: 32°F DB (0°C DB) 27°F WB (-2.9°C WB), Discharge Set Temperature: 72°F DB (22.0°C DB), Piping Length: 24.6 ft. (7.5m) Piping Lift: 0 ft. (0m)</p> <p>*2. Indoor Temperature Control: A control system to bring the room atmosphere temperature closer to the set point temperature of the wired controller, using a temperature sensor (remote sensor or thermistor in wired controller) mounted to any place in the room. Nominal capacity (indoor temperature control) is based on combination with VRF system and following conditions: Cooling Operation Conditions-Outdoor Temperature: 91°F DB (33.0°C DB) 82°F WB (28.0°C WB), Indoor Temperature: 81°F DB (27.0°C DB), Heating Operation Conditions-Outdoor Temperature: 32°F DB (0°C DB) 27°F WB (-2.9°C WB), Indoor Temperature: 68°F DB (20.0°C DB), Piping Length: 24.6 ft. (7.5m) Piping Lift: 0 ft. (0m)</p> <p>*3. The sound pressure level is based on the following conditions. 4.9 ft. (1.5m) beneath the units. The above data is measured in an anechoic chamber so that reflected sound should be taken into consideration in the field.</p>	

WALL MOUNTS

WALL UNITS



/// HIGH EFFICIENCY DC FAN MOTOR

The DC fan motor provides low-cost operation with a minimum power consumption as low as 20W, which is approximately 60% less than conventional air conditioning options.

/// QUIET OPERATION

Super silent DC fan motors and EEVs ensure quiet operation of C&H wall mounted units. Sleep Mode and Silent Mode can also be utilized for further noise reduction.

/// 6 FAN SPEEDS

6 indoor fan speeds are available to meet a variety of needs.

/// SELF-CLEAN FUNCTION

CHV wall mounts have a Self-Clean function which dries the coil to eliminate build-up of dust, mildew, and other airborne particles.



Model Name		CHV-07WTU	CHV-09WTU	CHV-12WTU	CHV-15WTU	CHV-18WTU	CHV-24WTU	CHV-28WTU	
Capacity	Cooling	Btu/h	7,500	9,600	12,300	15,400	19,100	24,200	28,700
	Heating	Btu/h	8,500	11,300	13,700	17,100	21,500	27,300	28,700
Input Power		W	20	20	30	30	30	70	80
Power Supply		V/Ph/Hz	208-230V / 1Ph / 60Hz						
Electrical Parameters	MCA	A	0.45	0.45	0.53	0.56	0.56	0.94	1.02
	MOP	A	15						
Airflow Rate		CFM	347/323/305/288/264/247	347/323/305/288/264/247	364/323/305/288/264/247	570/529/500/470/429/405	705/635/600/529/470/411	705/635/600/529/470/411	823/776/705/600/500/429
Sound Pressure Level		dB(A)	36/35/33/32/30/28	36/35/33/32/30/28	36/35/33/32/30/28	38/37/36/32/31/29	40/38/36/35/33/31	45/42/41/38/35/31	50/48/45/41/36/33
Dimensions (H x W x D)		in.	10.63x33.27x8	10.63x33.27x8	10.63x33.27x8	12.34x37.80x9.06	12.34x44.09x9.06	12.34x44.09x9.06	12.34x44.09x9.06
Weight		lbs.	20	20	20	30	35	35	35
Connection Pipe Diameter	Liquid	in.	1/4	1/4	3/8	3/8	3/8	3/8	3/8
	Gas	in.	3/8	3/8	1/2	1/2	5/8	5/8	5/8
	Drain		VP16						

Accessories Wall Mount Unit										
Wired Controllers				Wireless Controller	Central Controller	Motion Sensor	WiFi Adapter	Bacnet	CH-Checker	Switch Boxes
SPWT-A01	SPWT-B01	SPWT-WG01	SPRC-101	SPCC-D10	SPHNS-S01E	SPHM-64M	SPBN-H160	SPHCH-64	Single Box	Multi Box

- The nominal cooling capacity and heating capacity are based on following conditions: The above data was measured in an anechoic chamber so that reflected sound should be taken into consideration in the field. Cooling Operation Conditions Indoor Air Inlet Temperature: 80°F DB, 66°F WB Outdoor Air Inlet Temperature: 95°F DB
- Heating Operation Conditions Indoor Air Inlet Temperature: 68°F DB, Outdoor Air Inlet Temperature: 44°F DB, 42°F WB Piping Length: 2.6ft. Piping Lift: 0ft. The sound pressure level is based on following conditions: 2.6ft.(0.8m) below the unit and 3.3ft.(1m) in front of the unit. The above noise values are measured under the condition of air supply.
- The actual appearance of outdoor units may differ from photos.
- Specifications are subject to change without notice.

AIR HANDLER UNITS

MULTI POSITION AHU

KEY FEATURES

- Multi positioning installation is able to fit in different type of projects and room structures.
- 100% copper pipe
- Low noise DC Fan Motor
- Optional electric heater



Model Name			CHV-18MPAHU	CHV-24MPAHU	CHV-36MPAHU	CHV-48MPAHU	CHV-60MPAHU
Capacity	Cooling	Btu/h	18,000	24,000	36,000	48,000	60,000
	Heating	Btu/h	20,000	27,000	40,000	54,000	66,000
Power Supply	V/Ph/Hz		208-230V / 1Ph / 60Hz				
Electrical Parameters	MCA	A	2.27	2.68	2.68	5.57	7.92
	MOP	A	15				
Airflow Rate	CFM		600	765	1100	1400	1500
Sound Pressure Level	dB(A)		43/33	44/34	51	53	55
Dimensions (H x W x D)	in.		45x17.75x20.88	46x19.63x21.63	46x19.63x21.63	53.88x22x24	53.88x22x24
Weight	lbs.		125	135	135.5	204	204
Connection Pipe Diameter	Liquid	in.	1/4	3/8	3/8	3/8	3/8
	Gas	in.	1/2	5/8	5/8	5/8	5/8
	Drain		1 1/4				

Accessories MAHU							
Wired Controllers			Wireless Controller	Central Controller	Receiver Kit	Motion Sensor	WIFI Adapter
SPWT-A01	SPWT-B01	SPWT-WG01	SPRC-101	SPCC-D10	SPWRK-V02	SPHNS-S01E	SPHM-64M

Drain Pump	Bacnet	CH-Checker	Switch Boxes		<ol style="list-style-type: none"> The nominal cooling capacity is the combined capacity of the Cooper&Hunter standard split system. Cooling Operation Conditions Indoor Air Inlet Temperature: 80°F DB, 66°F WB, Outdoor Air Inlet Temperature: 95°F DB, Heating Operation Conditions Indoor Air Inlet Temperature: 68°F DB, Outdoor Air Inlet Temperature: 44°F DB, 42°F WB, Piping Length: 24.6ft, Piping Lift: 0ft The sound pressure level is based on following conditions: 4.9ft Beneath the Unit, With Discharge Duct(6.5ft.)and Return Duct(3.3ft.). Voltage of the power source for the indoor fan motor is 208V. The above data was measured in an anechoic chamber so that reflected sound should be taken into consideration in the field. The data for external pressure *)indicates Standard Pressure Setting values when a filter is not used. The actual appearance of outdoor units may differ from photos. Specifications are subject to change without notice.
SPEDP-DHP07/54	SPBN-H160	SPHCH-64	Single Box	Multi Box	

AIR HANDLER KIT

AHU CONNECTION KIT AND FUNCTIONS

Cooper&Hunter's AHU connection kit enables the connection of an air handler unit with a CHV6 system, providing more installation flexibility and convenience for connecting to previous ductwork in renovation projects.

AHU KIT FUNCTIONS: ON/OFF Control, Capacity Demand, Temperature Setting, and Set Operation Modes. A third-party AHU heat exchanger should be selected according to provided specifications and limitations. Neglecting these parameters could affect the life of the outdoor unit, the operating range or the reliability of operation.

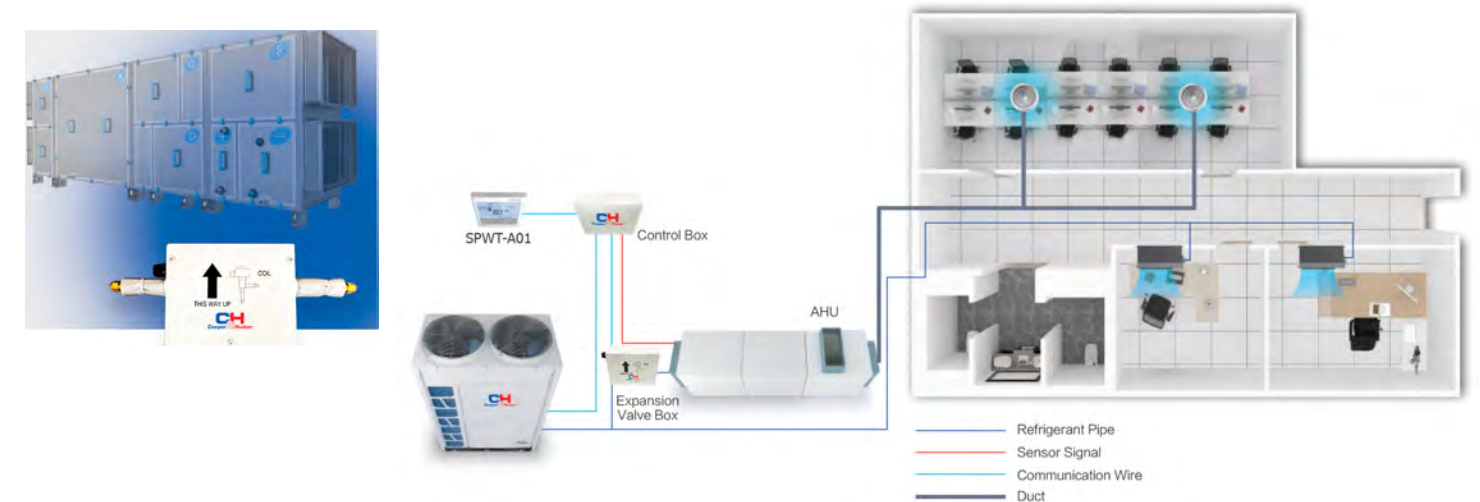

Model Name		SPAK-02	SPAK-04	SPAK-06	SPAK-10	SPAK-20	SPAK-30	
Power Supply	V/Ph/Hz	208-230V / 1Ph / 60Hz						
Nominal Capacity	Ton	1.5	3	5	8	16	24	
	HP	2	4	6	10	20	30	
Allowed Heat Exchanger Capacity (H/M/L)	Cooling	kBtu/h	19.4/17.1/13.6	38.2/30.7/24.2	54.6/47.8/38.2	95.5/85.3/68.2	191.1/177.4/170.6	290.0/279.8/273.0
	Heating	kBtu/h	24.2/19.1/15.7	42.7/34.1/27.3	61.4/54.6/42.7	107.5/95.5/76.4	245.0/204.7/191.1	324.2/313.9/307.1
Heat Exchanger Volume	Min	in. ³	34.8	62.9	117.2	237.4	516.9	754.3
	Max	in. ³	70.8	144.6	178.2	290.5	608.4	898.9
Equivalent Indoor Unit Capacity	Ton	1.5	3	5	8	16	24	
	HP	2	4	6	10	20	30	
Control Box Model	SPAK-01							
Expansion Valve Box Model	SPAK-02	SPAK-04	SPAK-06	SPAK-10	SPAK-20	SPAK-30		

Operation Conditions		Cooling			Heating		
Indoor Air Inlet Temperature	DB	80°F			68°F		
	WB	66°F			-		
Outdoor Air Inlet Temperature	DB	95°F			44°F		
	WB	-			42°F		

Accessories AHU Kit						
Wired Controllers	Central Controller	WIFI Adapter	Bacnet	CH-Checker	Switch Boxes	
SPWT-A01	SPCC-D10	SPHM-64M	SPBN-H160	SPHCH-64	Single Box	Multi Box



CONTROLLERS

Hydro Box Model Name			CHV-080HM	CHV-160HM	
Power Supply			208-230V / 1Ph / 60Hz		
Heating Capacity	kW		8	16	
	kBtu/h		27	54	
MCA	A		22.71	22.71	
MOP	A		25	25	
Dimensions	External (HxWxD)	in.	35.03x20.47x12.6		
	Packaging (HxWxD)	in.	44.09x23.4x18.2		
Weight	Net	lbs.	121	128	
	Gross	lbs.	159	165	
Heat Exchanger			Plate Heat Exchanger		
Heat Exchanger Insulation Material			Elastomeric Foam		
Water Production	Heating	°F	59-131		
	DHW (with Electric Heater)	°F	77-167		
Sound Pressure		dB(A)	33		
Sound Power		dB(A)	46		
Piping Connections	Gas	in.	5/8		
	Liquid	in.	3/8		
Water Pump	Type	-	DC Motor		
	Speed	-	Inverter Control		
	Pumping Head	ft.	41		
	Pumping Head for Water Circuit	ft.	16.4		
	Power Input	w	100	160	
Booster Heating			kW		
Water Filter	Diameter Perforations	in.	0.33		
	Material	-	Hpb59-1		
Water Circuit	Piping Connections Diameter	in.	1 1/4 NPT		
	Shut Off Valve	-	Yes		
	Drain Valve	-	Yes		
	Safety Valve	PSI	43.5		
	Air Purge Valve	-	Yes		
Nominal Water			GPM	6.07	12.1
Expansion Vessel	Volume	GAL	2.11		
	Max. Water Pressure	PSI	43.5		

Operation Range

Indoor Unit Cooling			Indoor Unit Heating			Water Module Heating (DHW)			Water Module Heating (floor heating)		
	Maximum	Minimum		Maximum	Minimum		Maximum	Minimum		Maximum	Minimum
Indoor	90°F DB / 73°F WB	70°F DB / 59°F WB	Indoor	81°F DB	59°F DB	Inlet Water	129°F	50°F	Inlet Water	129°F	50°F
Outdoor	126°F DB*	14°F DB	Outdoor	62°F WB*	-13°F WB**	Outdoor	109°F WB	-13°F WB**	Outdoor	62°F WB	-13°F WB**

SPWT-WG01



- Cool/Heat/Auto/Dry/Fan
- Fan speed control
- 24-hour/7-Day timer
- Check function
- Error code history display
- PCB inspection indoor/outdoor
- Backlight control
- Wireless control available
- Breeze mode
- Eco mode (energy saving mode)
- Sleep mode
- 3D airflow customization
- Dehumidification
- Performance monitoring
- Air filter cleaning reminder
- Automatic test run
- Self-diagnosis function
- Built-in temperature sensor
- Individual louver control
- Quiet mode / silent mode
- Self-cleaning

SPWT-A01



- Cool/Heat/Auto/Dry/Fan
- Air filter cleaning reminder
- Fan speed control
- 1°F temperature setting
- 3D airflow customization
- 72-hour timer
- Backlight control
- Up to 16 indoor units can be connected
- Error code display
- Built-in temperature sensor
- Dehumidification
- Check function
- One touch test run
- Self cleaning
- Multiple speeds
- Swinging louvers

SPWT-B01



- Cool/Heat/Auto/Dry/Fan
- Fan speed control
- 24-hour timer
- Check function
- Error code history display
- PCB inspection indoor/outdoor
- Backlight control
- Wireless control available
- Breeze mode
- Eco mode (energy saving mode)
- Sleep mode
- 3D airflow customization
- Dehumidification
- Performance monitoring
- Air filter cleaning reminder
- Automatic test run
- Self-diagnosis function
- Built-in temperature sensor
- Individual louver control
- Quiet mode / silent mode
- Self-cleaning

SPRC-101



- Performance monitoring
- Automatic test run
- Fan speed control
- Backlight control
- Individual louver control
- Sleep mode
- 3D airflow customization
- Fan speed control
- 24-hour timer
- Self-diagnosis function
- Built-in temperature sensor
- Breeze mode
- ECO (energy saving mode)
- Sleep mode
- Self-cleaning function

WIRELESS RECEIVER KIT

- SPWRK-T03
- SPWRK-Z01
- SPWRK-V02
- SPWRK-X01H



CENTRALIZED CONTROLLER SPCC-D10



- Max. 160 connected IDUs
- VRF and ATW system control
- Weekly/holiday schedule
- Remote control with web access
- Password setting
- Multilingual - 14 languages

External Input/Output Setting: Support external input and output signal control from 3rd-party control.

Temperature Limitation: You can set higher limit of heating and lower limit of cooling to save energy.

Intuitive Interface: Self-cleaning and six fan-speed setting can be set with a simple touch to ensure you more health and comfort.

IDU Alternate Operation Setting: IDUs alternate operation can be realized by a simple touch, simplifying air-conditioning control of equipment rooms or data centers.

High-resolution Color Screen: Smart Touch II adopts a minimalist and fashionable appearance design, equipped with a high-resolution 10-inch color screen, providing users with a more user-friendly usage experience.

Error Reminder: Error reminder email when malfunction occurs helps to get the information in time.

BUILDING MANAGEMENT SYSTEM (BMS)

A Building management system is a computer-based system which offers convenient control and monitoring of multiple units in HVAC systems to ensure safe and efficient operation.

MODBUS

- ON/OFF control of all units
- Temperature setting
- Operating mode setting
- Inlet air temperature monitoring
- Airflow setting and monitoring
- Alarm monitoring and code display

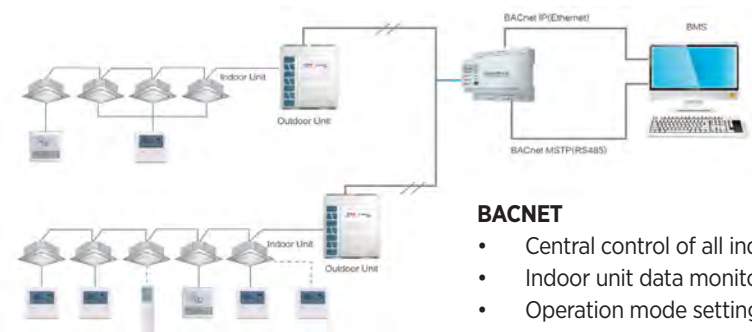
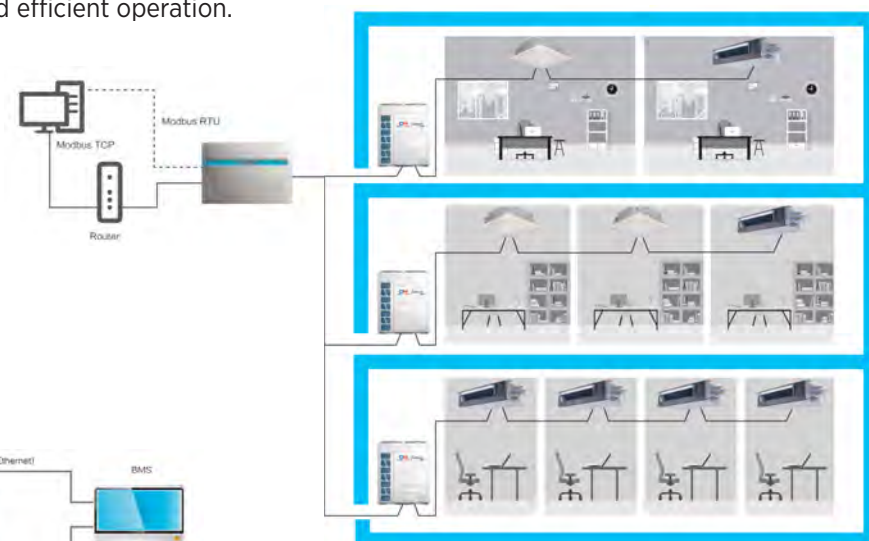

BACNET

- Central control of all indoor units
- Indoor unit data monitoring
- Operation mode setting
- Louver swing control
- Activation/deactivation of wall thermostat

SWITCH BOX

SWITCH BOX FEATURES

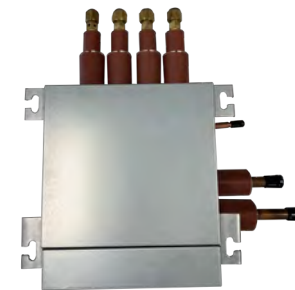

Cooper & Hunter's CHV6 URBAN series utilizes the optional switch box accessory to achieve heat recovery capabilities. Heat recovery systems utilize 3 refrigerant pipes, as opposed to only 2 in heat pump systems, to enable simultaneous cooling and heating.

- Quantity ports for indoor units (1, 4, 8, 12, 16)
- Maximum total capacity of connected indoor units per port: 290Btu/h
- Does not require drainpipes or drain connections
- Compact and simple design
- Combination flexibility between single and multiple branches
- Fewer joints, hooks, and spare parts for ease of installation

Model Name		Single Branch		Multiple Branch				
		SPSBD-16	SPSBD-28	SPMBD-4/45	SPMBD-8/85	SPMBD-12/85	SPMBD-16/85	
Power Supply	V/Ph/Hz	208-230V / 1Ph / 60Hz						
Net Weight	lbs.	13.9	14.1	31.1	55.6	78.3	103	
Number of Ports (Indoor Unit)		1	1	4	8	12	16	
Max Number of Connected Indoor Units per Port		8	8	8	8	6	6	
Max Total Capacity of Connected Indoor Units per Port	kW	16	28	16	16	16	16	
	Btu/h	≤54	≤96	≤54	≤54	≤54	≤54	
	RT	4.5	8	4.5	4.5	4.5	4.5	
Max Total Capacity of All Connected Indoor Units	kW	16	28	44.8	85	85	85	
	kBtu/h	≤54	≤96	≤154	≤290	≤290	≤290	
	RT	4.5	8	12.7	24	24	24	
Operation Sound	dB(A)	33	33	31	31	34	34	
Running Current	A	0.1	0.1	0.2	0.4	0.6	0.8	
Recommended Fuse/Breaker Size	in.	15						
Outer Dimensions (HxWxD)	in.	7.5x11.88x8.44	7.5x11.88x8.44	10.25x11.94x13.88	10.25x21.38x13.88	10.25x40.25x13.88	10.25x40.25x13.88	
Refrigerant Piping	Gas Line (High/Low Pressure)	in.	5/8	5/8	7/8	7/8	1 1/8	1 1/8
	(High/Low Pressure) Gas Line (Low Pressure)	in.	3/4	3/4	1	1 1/8	1 1/4	1 1/4
	Liquid Line	in.	-	-	1/2	1/2	3/4	3/4
Refrigerant Piping	Gas Line		5/8	3/4	5/8	5/8	5/8	5/8
	Liquid Line		-	-	3/8	3/8	3/8	3/8

SMART MOTION SENSOR

With the use of a dynamic motion sensor, the CHV6 system can prioritize cooling and heating functions in occupied rooms and high traffic areas. The round, white sensor can be mounted discretely on a wall or ceiling up to 23 ft high to detect movement within a 366 sq. ft area. This sensor is compatible with CHV wall mounts and slim ducts.



- High accuracy: Airflow automatically adjusts based on the amount of motion detected within range of the sensor.
- Wide Range: High motion detection within a 366 SF area.
- High energy saving: Units can be set to turn on and off automatically based on room occupancy.





cooperandhunter.us